

# Schlüter®-BEKOTEC-THERM

Ceramic thermal comfort floor

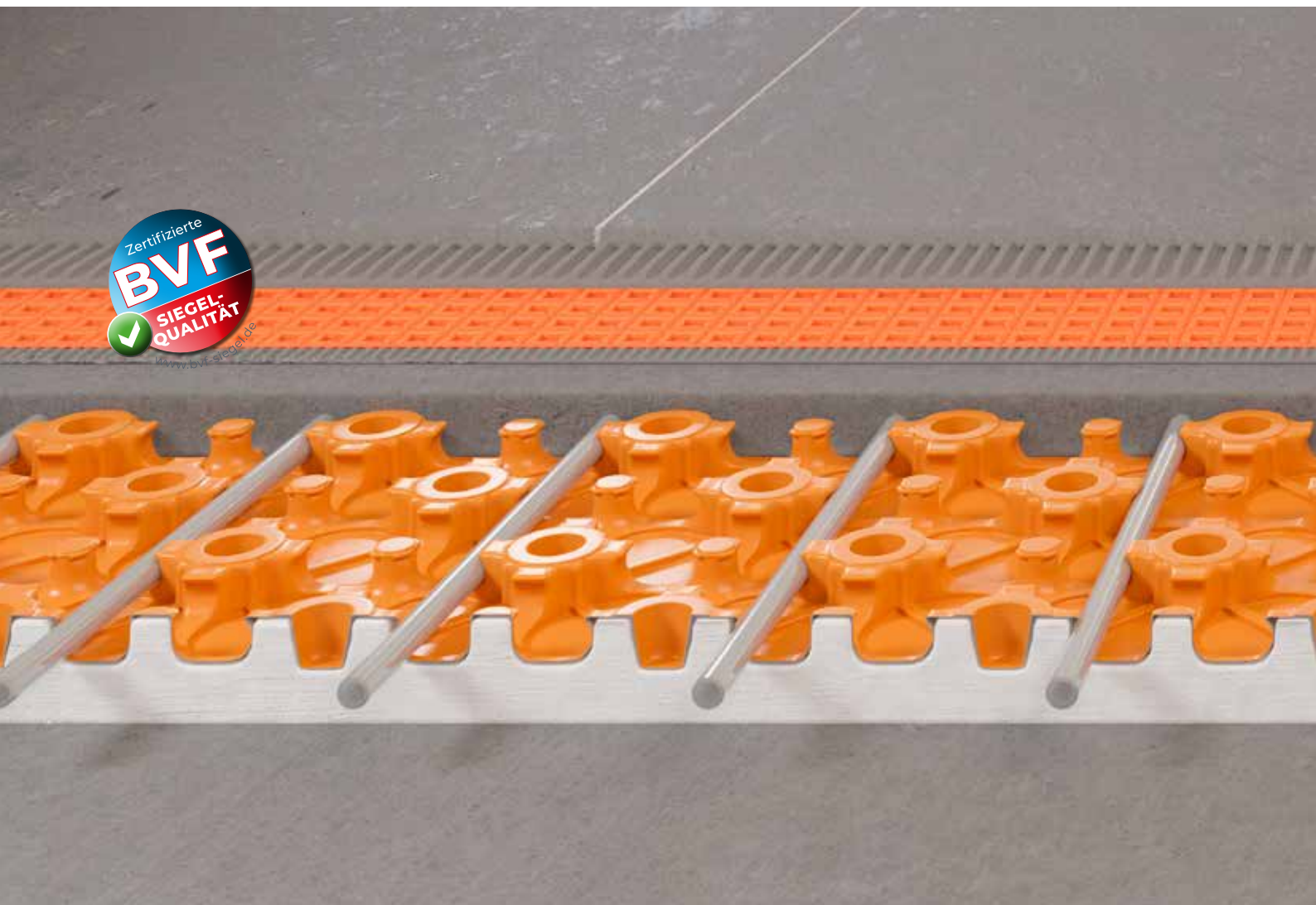

Technical Manual



Werner Schlüter  
**SCHLÜTER-SYSTEMS KG**



## About this manual

### The design principle of the ceramic thermal comfort floor

The innovative Schlüter-BEKOTEC-THERM heating system is referred to as a “ceramic thermal comfort floor” to emphasise the fact that our company views the heating system of the floor as an overall floor assembly, in which all components, design planning and construction must seamlessly fit together. After all, to meet the many requirements, the “ceramic thermal comfort floor” must provide insulation, heating, cooling and waterproofing in wet areas, while also absorbing traffic loads and serving as a visually appealing design element.

The experience of the past has shown how difficult it is to achieve a satisfactory balance between the aspects of construction, physics and heating technology in the overall floor assembly. As a consequence, conventional heated screeds with ceramic and natural stone coverings frequently buckle and form cracks. This is mainly attributable to the fact that screed and ceramics expand and contract at different rates due to their different heat expansion coefficients during temperature changes.

The provisions of the corresponding standards, for example the regulations that specify the thickness of the screed, the position and type of movement joints, the construction of reinforcement inserts, or the maximum residual moisture for tile installation, do not solve the physical problems encountered in construction.

The relatively large mass of screed typically used in conjunction with conventional radiant floor heating systems means the heating system is slow to respond to temperature changes.

With our integrated BEKOTEC-THERM system we have developed a structure that solves all these problems in one internationally patented assembly. In this regard, the name **“BEKOTEC”** stands for the technique of the assembly construction and **“THERM”** for the heating components. BEKOTEC-THERM is based on a thin layer floor assembly of cement or gypsum based screeds, which are applied on top of the BEKOTEC studded panels, and reduces the shearing tensions of the screed surface in the studded grid. With the help of Schlüter uncoupling mats, ceramic tiles can be installed as soon as the screed is ready to bear weight.

Our THERM components series is a heating technology that is an exact match for BEKOTEC and includes everything from heating pipes to electronic control systems. The relatively small amount of screed and the proximity of the heating pipes to the surface allow for a quick reaction to temperature changes. That makes BEKOTEC-THERM a quick reacting “ceramic thermal comfort floor” that can be operated with great energy efficiency at very low supply temperatures. Of course, other flooring materials can be installed over the BEKOTEC screed as well.

BEKOTEC-THERM, which is equally suited for new constructions and the refurbishment of older buildings, offers developers many advantages and true added value.

Since the applicable DIN standards, regulations and even legislation tend to make construction work more complicated instead of easier, this manual was written to document the construction steps of installing a BEKOTEC-THERM ceramic thermal comfort floor in a simple and understandable way.

Yours sincerely,  
Schlüter-Systems KG



Reducing stresses in the screed...



....without unpleasant surprises.



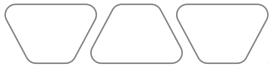

# Advantages of Schlüter®-BEKOTEC-THERM

## You will love it



### Easy

The installation of Schlüter-BEKOTEC-THERM does not require complex components or expensive construction materials. All you need is simple technology, proven for decades. You can start heating the screed just 7 days after installing the ceramic/natural stone tile covering. Depending on the design temperature, the heat curing phase only takes 2–3 days (start with a water temperature of 25 °C, then gradually increase the temperature by up to 5 °C a day until the design temperature has been reached).



### Safe

Are you planning to install a ceramic tile covering? Great! Schlüter-BEKOTEC-THERM keeps ceramic coverings permanently crack-free – starting from tile formats of 5 x 5 cm, without any size limitation. That means you can safely install and maintain stylish large formats free of damage. Another advantage: BEKOTEC is virtually buckle-free, which relegates torn skirting joints to the past.



### Quick

If using conventional cementitious screed and ceramic tile coverings, there is no need to measure or reach specific residual moisture levels. Your tile installation can start as soon as the screed is ready to bear weight. Without complex and expensive special construction materials, your customer will be able to move in 28 days earlier, which saves time and money.



### Easy

The BEKOTEC-THERM system does not require joints in the screed (except for structural expansion joints etc.). The control joints in the top covering specified by the relevant guidelines can therefore be positioned independent of the screed. That eliminates unsightly joints in the tile pattern and creates results that speak for themselves.



### Sustainable

Due to its low assembly height, the BEKOTEC-THERM system can be operated with particularly low supply temperatures. That makes it an excellent fit for combined use with sustainable, modern heat pumps. As an added benefit, the lower screed volume also decreases the consumption of resources such as sand and cement, which significantly lowers the ecological footprint.



### System warranty

Schlüter-Systems KG offers an expanded, project-specific warranty for users of the BEKOTEC-THERM floor covering assembly. It includes sufficient weight bearing ability and cracks forming in coverings made of ceramic tiles, natural stone or agglomerated stone.

To qualify for the warranty, BEKOTEC-THERM systems must be installed in accordance with the relevant product data sheets and the specifications of Schlüter-Systems KG.

Questions? Our sales team will be pleased to assist you!

Phone: +49 2371 971-91518

# Where to find help

We are happy to help

## Technical consulting

Our Technical Department will be pleased to assist with any questions you may have concerning the assembly and the corresponding heating and control technology. Consultation on bespoke designs and solutions for your project are available on request.

Schlüter-BEKOTEC-THERM has been tested and approved for use with multiple tile adhesives (technical approval in Germany, abP), light-weight screeds and bound fill. Depending on the construction project, special arrangements and additional tests are available on request.

## Heating capacity calculation

We use a special software solution to precisely determine the heating load of buildings and individual rooms on the basis of the corresponding drawings and data in order to guarantee optimum heat distribution of the BEKOTEC-THERM ceramic thermal comfort floor.

## Tender documents

Our own tender texts can be found online at [bekotec-therm.com](http://bekotec-therm.com) and [schlueter-systems.com](http://schlueter-systems.com) for downloading. We can develop customised materials for tender based on the technical design of Schlüter-BEKOTEC-THERM as a radiant panel heating system.

## On site consulting

Please contact our offices if you need professional consulting onsite. We will be pleased to arrange an appointment – for BEKOTEC-THERM and more.

## Schlüter-Systems training

Our company offers training and workshops with particular focus on BEKOTEC-THERM for tradespeople, installation companies and sales staff. Please contact us to find out more about these events!



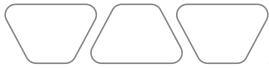

# Schlüter®-BEKOTEC-THERM

## All systems at once

### Schlüter®-BEKOTEC-EN 23 FI 30



## The quiet type with insulation

With 30 mm heat and sound insulation (DES 039/CP 2) for use in areas with heat insulation requirements, e.g. on storey ceilings.

- ✓ Assembly heights: 61–78 mm (plus DITRA uncoupling mat)
- ✓ Screed coverage 8–25 mm
- ✓ With integrated heat and sound insulation; can be combined with additional heat insulation materials
- ✓ Up to 28 dB improvement in sound insulation
- ✓ Weight per unit area from 58 kg/m<sup>2</sup>
- ✓ 75 mm installation grid
- ✓ 14 or 16 mm heating pipe diameter
- ✓ Heat output up to 100 W/m<sup>2</sup>

### Schlüter®-BEKOTEC-EN 2520 P/EN 1520 PF

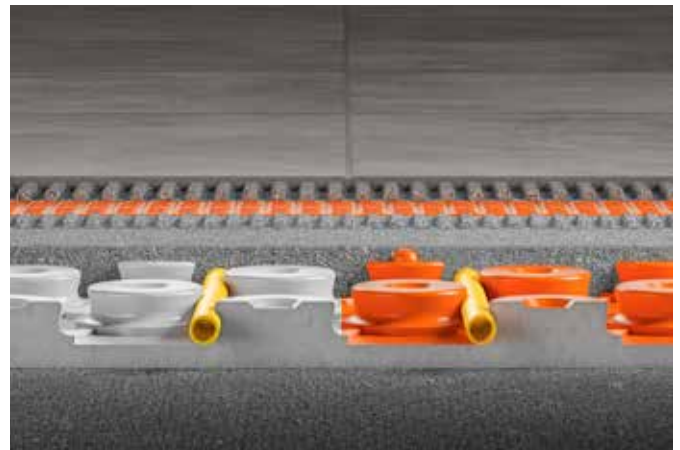

## The insulated type

With integrated insulation (DEO 033) for use in areas with sound impact and thermal insulation requirements, e.g. over base plates or storey ceilings.

- ✓ Assembly heights: 52–69 mm (plus DITRA uncoupling mat)
- ✓ Screed coverage 8–25 mm
- ✓ With integrated heat insulation; can be combined with additional insulation materials
- ✓ Weight per unit area from 57 kg/m<sup>2</sup>
- ✓ 75 mm installation grid
- ✓ 16 mm heating pipe diameter
- ✓ Heat output up to 100 W/m<sup>2</sup>

## Schlüter®-BEKOTEC-EN 23 F



## The all-round talent

Universal assembly for use with and without insulation. Low assembly height, ideal for new construction and renovation.

- ✓ Assembly heights: 31–48 mm (plus DITRA uncoupling mat)
- ✓ Screed coverage 8–25 mm
- ✓ Without insulation, can be combined with insulation materials
- ✓ Weight per unit area from 57 kg/m<sup>2</sup>
- ✓ 75 mm installation grid
- ✓ 14 mm heating pipe diameter
- ✓ Heat output up to 100 W/m<sup>2</sup>

## Schlüter®-BEKOTEC-EN 23 F PS



## The self-adhesive all-rounder

Universal assembly for use with and without insulation. Low assembly height, self-adhesive, ideal for new construction and renovation.

- ✓ Assembly heights: 31–48 mm (plus DITRA uncoupling mat)
- ✓ Screed coverage 8–25 mm
- ✓ Without insulation, can be combined with insulation materials
- ✓ Self-adhesive (Peel & Stick)
- ✓ Weight per unit area from 57 kg/m<sup>2</sup>
- ✓ 75 mm installation grid
- ✓ 14 or 16 mm heating pipe diameter
- ✓ Heat output up to 100 W/m<sup>2</sup>



## Schlüter®-BEKOTEC-EN 18 FTS



### The quiet type

Our system achieves a sound insulation improvement of up to 25 dB according to DIN EN ISO 10140-1 to optimise impact sound.

- ✓ Assembly heights: 31–43 mm (plus DITRA uncoupling mat)
- ✓ Screed coverage 8–20 mm
- ✓ With integrated heat and sound insulation; can be combined with additional heat insulation materials
- ✓ Up to 25 dB sound insulation improvement according to DIN EN ISO 10140-1
- ✓ Weight per unit area from 52 kg/m<sup>2</sup>
- ✓ 50 mm installation grid
- ✓ 12 mm heating pipe diameter
- ✓ Heat output up to 100 W/m<sup>2</sup>

## Schlüter®-BEKOTEC-EN 12 FK

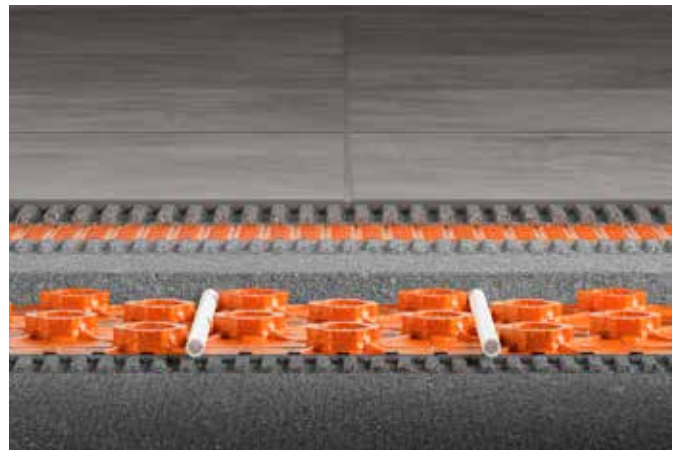

### The lightweight type

Our lightest and thinnest assembly is the best choice for minimal weight. Please contact us if you need options for further assembly weight reduction.

- ✓ Assembly heights: 20–27 mm (plus DITRA uncoupling mat)
- ✓ Screed coverage 8–15 mm
- ✓ Bonding to load-bearing substrates (no further insulation possible)
- ✓ Weight per unit area from 40 kg/m<sup>2</sup>
- ✓ 50 mm installation grid
- ✓ 10 mm heating pipe diameter
- ✓ Heat output up to 100 W/m<sup>2</sup>

## Schlüter®-BEKOTEC-EN 12 FK PS



## The self-adhesive lightweight

Our lightest and thinnest assembly is the best choice for minimal weight. Please contact us if you need options for further assembly weight reduction.

- ✓ **Assembly heights: 20–27 mm  
(plus DITRA uncoupling mat)**
- ✓ **Screed coverage 8–15 mm**
- ✓ **Bonding to load-bearing  
substrates  
(no further insulation possible)**
- ✓ **Self-adhesive (Peel & Stick)**
- ✓ **Weight per unit area from 40 kg/m<sup>2</sup>**
- ✓ **50 mm installation grid**
- ✓ **10 mm heating pipe diameter**
- ✓ **Heat output up to 100 W/m<sup>2</sup>**



# Contents

Content	Page
<b>Installation overview (with page references)</b>	
■ 9 step guide . . . . .	12 – 13
<b>Application and properties</b>	
■ Advantages for users/thermal comfort . . . . .	15
■ Areas of application . . . . .	16 + 23
■ Thermal properties . . . . .	17 – 18
■ Renewable sources of energy and modern energy technologies . . . . .	19 – 22
■ Traffic loads/ screed covers . . . . .	24 – 25
<b>Prerequisites and implementation</b>	
■ Installation notes, structural and/or movement joints in the load bearing substrate, thermal/sound insulation and separating layers . . . . .	27 – 29
■ Edge strips and edge joints . . . . .	30
■ Joints in the Schlüter-BEKOTEC system . . . . .	31
■ Screeds for BEKOTEC systems . . . . .	31 – 32
<b>Additional system products for ceramic tiles and natural stone ceramic tiles and natural stone</b>	
■ Installation of Schlüter uncoupling mats . . . . .	32
■ Joints in the surface covering . . . . .	33
■ Wetrooms and bathrooms . . . . .	33
■ Schlüter-DITRA-HEAT-E . . . . .	173 – 175
<b>Product service and planning materials</b>	
■ Our service . . . . .	34
■ Various floor coverings.. . . .	148 – 150
■ Heat insulation in accordance with the Building Energy Act and DIN EN 1264-4 . . . . .	151 – 152
■ Floor assemblies for various application areas . . . . .	153 – 156
■ Performance diagrams, explanation . . . . .	157
■ Certified quality . . . . .	158
<b>Innovative system solutions</b>	
■ Cooling function with BEKOTEC control technology . . . . .	137
■ Application and scope . . . . .	159

Content	Page
<b>Schlüter®-BEKOTEC-EN 23 FI 30</b>	
■ Product properties . . . . .	36
■ System assembly . . . . .	37
■ General. . . . .	38
■ Installation of the studded screed panel + heating pipes. . . . .	38 – 39
■ Performance diagrams for 16 mm heating pipe . . . . .	40 – 44
■ Performance diagrams for 14 mm heating pipe . . . . .	45 – 49
<b>Schlüter®-BEKOTEC-EN/P or EN/PF</b>	
■ Product properties . . . . .	50
■ System assembly . . . . .	51
■ General. . . . .	52
■ Installation of the studded screed panel + heating pipes. . . . .	52 – 53
■ Performance diagrams for 16 mm heating pipe. . . . .	54 – 58
<b>Schlüter®-BEKOTEC-EN 23 F</b>	
■ Product properties . . . . .	60
■ System assembly . . . . .	61
■ General. . . . .	62
■ Installation of the studded screed panel + heating pipes . . . . .	62 – 63
■ Performance diagrams for 14 mm heating pipes. . . . .	64 – 68
<b>Schlüter®-BEKOTEC-EN 23 F PS</b>	
■ Product properties . . . . .	70
■ System assembly . . . . .	71
■ General. . . . .	72
■ Installation of the studded screed panel + heating pipes. . . . .	72 – 73
■ Performance diagrams for 16 mm heating pipes . . . . .	74 – 78
■ Performance diagrams for 14 mm heating pipes. . . . .	79 – 83
<b>Schlüter®-BEKOTEC-EN 18 FTS</b>	
■ Product properties . . . . .	84
■ System assembly . . . . .	85
■ General. . . . .	86
■ Installation of the studded screed panel + heating pipes. . . . .	86 – 87
■ Performance diagrams for 12 mm heating pipes. . . . .	88 – 92
<b>Schlüter®-BEKOTEC-EN 12 FK</b>	
■ Product properties . . . . .	94
■ System assembly . . . . .	95
■ General. . . . .	96
■ Installation of the studded screed panel + heating pipes. . . . .	96 – 97
■ Performance diagrams for 10 mm heating pipes. . . . .	98 – 102
<b>Schlüter®-BEKOTEC-EN 12 F PS</b>	
■ Product properties . . . . .	104
■ System assembly . . . . .	105
■ General. . . . .	106
■ Installation of the studded screed panel + heating pipes. . . . .	106 – 107
■ Performance diagrams for 10 mm heating pipes. . . . .	108 – 112

Content	Page
<b>Schlüter®-BEKOTEC-THERM</b>	
■ System components + accessories . . . . .	114 – 115
<b>Technical data – system products</b>	
■ Schlüter-BEKOTEC-THERM-HR system heating pipe . . . . .	117 – 119
■ Pressure loss diagram, system pipes . . . . .	160
■ Distribution cabinets . . . . .	120 – 121
■ Fixed value control – FRS – supply temperature, use, function, planning example . . . . .	122 – 125
■ Connection set, calorimeter – PW . . . . .	126
■ Heating circuit distributor DN 25 – HVT/DE and HVP . . . . .	127 – 130
■ Hydronic balancing. . . . .	131
■ Actuators . . . . .	132 – 133
■ Room temperature control technology . . . . .	134 – 135
<b>Floor heating for single heating circuits</b>	
■ RTB and RTBR return temperature limit valves with remote sensor. . . . .	139 – 144
<b>Attachments</b>	
I.I Pressure loss diagrams for the BEKOTEC system/accessories . . . . .	160 – 162
I.II Sound measurement. . . . .	163
II.I Project engineering data sheets . . . . .	164 – 166
II.II Project description . . . . .	167
II.III Window specifications . . . . .	168
III Filling, flushing, and venting . . . . .	169
IV Pressure sample report . . . . .	170
V Heating up and cure heating screeds with non ceramic coverings . . . . .	171
VI Certificate for CM measurement. . . . .	172
Standards and regulations. . . . .	176



# The 9 point guide for surface coverings of tile, natural stone or ceramics

<b>1</b>	<b>Traffic load acc. to DIN 1991</b> Ceramic tiles e.g. in industrial premises, workshops, warehouses (without forklifts) Observe static requirements	<i>see pages 24 – 25</i>		
<b>2</b>	<b>General structural prerequisites</b> Installation notes, general requirements and structural prerequisites, screeds ...	<i>see pages 27 – 30</i>		
<b>3</b>	<b>Screed cover/calculation</b> Depending on the studded screed panel – match with Schlüter-DITRA uncoupling mats (with various surface coverings, if applicable)	<i>see pages 24, 32</i>		
<b>4</b>	<b>Joints in the screed</b> = Structural joints, existing joints, sound insulation joints (screed reductions, e.g. at door transitions, must be separated with the expansion joint profiles Schlüter-DILEX-DFFP) Observe architectural joint design	<i>see pages 30, 31</i>		
<b>5</b>	<b>Joints in the surface covering</b> (use Schlüter-DILEX movement or stress relieving profiles) Observe architectural joint design	<i>see page 33</i>		
<b>6</b>	<b>Filling, flushing, and venting</b> <b>Leak testing according to DIN EN 1264 (with report)</b> ... to be completed before installing the screed (test with double operating pressure, at least 6 bar)	<i>see page 31 + page 169 – Attachment III</i> <i>see page 31 + page 170 – Attachment IV</i>		
<b>7</b>	<b>Installation of screed</b> ... and allocation of the matching system edge strips	<i>see pages 30 – 32</i>		
<b>8</b>	<table border="1" style="width: 100%; border-collapse: collapse;"> <tr> <td style="width: 50%; padding: 5px;"> <b>Installation of the Schlüter uncoupling mat and the surface covering</b>  ... on cement screeds CT-C20 to C35 F4 (max. F5)  after reaching initial readiness to bear weight  <i>(observe</i>  <i>Data sheet 6.1 DITRA</i>  <i>Data sheet 6.2 DITRA-DRAIN</i>  <i>Data sheet 6.4 DITRA-HEAT</i>  <i>Data sheet 6.5 DITRA-HEAT-PS</i>  <i>Data sheet 6.7 DITRA-PS)</i> </td> <td style="width: 50%; padding: 5px;"> ... on flowing screeds CA-C20 to C35 F4 (max. F5)  with residual moisture ≤ 2 %  <i>(observe</i>  <i>Data sheet 6.1 DITRA</i>  <i>Data sheet 6.2 DITRA-DRAIN</i>  <i>Data sheet 6.4 DITRA-HEAT</i>  <i>Data sheet 6.5 DITRA-HEAT-PS</i>  <i>Data sheet 6.7 DITRA-PS)</i>  <b>CM measurement by installer of surface covering</b>  - If necessary, surface treatment (in accordance with specifications of screed manufacturer) </td> </tr> </table>	<b>Installation of the Schlüter uncoupling mat and the surface covering</b> ... on cement screeds CT-C20 to C35 F4 (max. F5) after reaching initial readiness to bear weight <i>(observe</i> <i>Data sheet 6.1 DITRA</i> <i>Data sheet 6.2 DITRA-DRAIN</i> <i>Data sheet 6.4 DITRA-HEAT</i> <i>Data sheet 6.5 DITRA-HEAT-PS</i> <i>Data sheet 6.7 DITRA-PS)</i>	... on flowing screeds CA-C20 to C35 F4 (max. F5) with residual moisture ≤ 2 % <i>(observe</i> <i>Data sheet 6.1 DITRA</i> <i>Data sheet 6.2 DITRA-DRAIN</i> <i>Data sheet 6.4 DITRA-HEAT</i> <i>Data sheet 6.5 DITRA-HEAT-PS</i> <i>Data sheet 6.7 DITRA-PS)</i> <b>CM measurement by installer of surface covering</b> - If necessary, surface treatment (in accordance with specifications of screed manufacturer)	<i>see pages 32 + 148</i>
<b>Installation of the Schlüter uncoupling mat and the surface covering</b> ... on cement screeds CT-C20 to C35 F4 (max. F5) after reaching initial readiness to bear weight <i>(observe</i> <i>Data sheet 6.1 DITRA</i> <i>Data sheet 6.2 DITRA-DRAIN</i> <i>Data sheet 6.4 DITRA-HEAT</i> <i>Data sheet 6.5 DITRA-HEAT-PS</i> <i>Data sheet 6.7 DITRA-PS)</i>	... on flowing screeds CA-C20 to C35 F4 (max. F5) with residual moisture ≤ 2 % <i>(observe</i> <i>Data sheet 6.1 DITRA</i> <i>Data sheet 6.2 DITRA-DRAIN</i> <i>Data sheet 6.4 DITRA-HEAT</i> <i>Data sheet 6.5 DITRA-HEAT-PS</i> <i>Data sheet 6.7 DITRA-PS)</i> <b>CM measurement by installer of surface covering</b> - If necessary, surface treatment (in accordance with specifications of screed manufacturer)			
<b>9</b>	<b>Heating up/start up</b> 7 days after completion of the covering at the earliest. Start at 25 °C, and increase the water supply temperature by ≤ 5 °C every day until the specified design temperature is reached	<i>see page 150</i>		

# The 9 step guide for surface coverings of non-ceramic materials

1	<b>Traffic load acc. to DIN 1991</b>			<i>see page 25</i>
	Carpet, vinyl, PVC, linoleum, cork	Parquet without tongue and groove connection	Parquet with tongue and groove connection	Floating parquet, laminate and coverings with click system
Observe static requirements				
2	<b>General structural prerequisites</b>			<i>see pages 27 – 30</i>
Installation notes, general requirements and structural prerequisites, screeds ...				
3	<b>Screed cover/calculation</b>			<i>see pages 24, 25, 32</i>
Depending on the studded screed panel – match with Schlüter-DITRA uncoupling mats (with various surface coverings, if applicable)				
4	<b>Joints in the screed</b>			<i>see pages 30, 31</i>
	= structural joints, existing joints, sound insulation joints (screed reductions, e.g. at door transitions, must be separated with the expansion joint profiles Schlüter-DILEX-DFP) Areas with moisture sensitive covering materials that adjoin ceramic coverings created with Schlüter-DITRA uncoupling mats must be protected from permeating moisture			
Observe architectural joint design				
5	<b>Joints in the surface covering</b>			<i>see page 33</i>
	... in accordance with specifications of flooring manufacturer or other technical standards (use Schlüter-DILEX movement joint profiles)			
Observe architectural joint design				
6	<b>Filling, flushing, and venting</b>			<i>see page 31 + page 169 – Attachment III</i>
	<b>Leak testing according to DIN EN 1264 (with report)</b>			<i>see page 31 + page 170 – Attachment IV</i>
If using flowing screed in conjunction with Schlüter-BEKOTEC, use the matching BEKOTEC edge strips for the studded screed panels				
7	<b>Installation of screed</b>			<i>see pages 29 – 30</i>
... and allocation of the matching system edge strips				
8	<b>Installation instructions for non ceramic floor coverings</b>			<i>see pages 148 – 149</i>
	<b>Cure heating (with report) /CM-measurement</b>			<i>see pages 171 + 172 - Attachments V + VI</i>
... after CM measurement by installer of surface covering (observe specifications and guidelines of flooring and adhesive manufacturer). Start: 7 days after completion of the screed at the earliest. Start at 25 °C, and increase the supply temperature by ≤ 5 °C every day to a maximum of 35 °C				
9	<b>Installation of the surface covering</b>			<i>see pages 148 – 149</i>
... without the uncoupling mat directly on the cooled screed once the residual moisture content has been reached				
Observe manufacturer guidelines				



# Saving energy with Schlüter®-BEKOTEC-THERM

Scientific study

## Schlüter-BEKOTEC-THERM – considerable savings potential

The renowned Dresden Institute for Building Systems Engineering Research (ITG) compared the thin layer floor heating system BEKOTEC-THERM with a conventional radiant floor heating as a wet system in the scope of a research project. The assembly of the two systems was performed in accordance with the customary instructions and standards of the manufacturers. The results revealed remarkable energy differences between the conventional floor heating system and BEKOTEC-THERM. Thus, energy savings from the use of a heat pump as the source of heat, were up to **9.5%**.

The systems were tested with a simulation program of Dresden Technical University, which specifies the same framework conditions for both assemblies. The starting point was a detached house with a living space of 160 m<sup>2</sup>, parallel buffer cylinder and an air-to-water heat pump as the source of heat. The study incorporated three different thermal insulation levels for the homes, namely the Thermal Insulation Ordinance (WSVO) in the versions of 1982 and 1995 as well as the Energy Savings Ordinance (EnEV) of 2004. Finally, the study also distinguished two different operating modes of the floor heating systems (lowering phase): The heating system was operated continuously or intermittently (time controlled). Additionally, the operation was simulated over the course of the day.



Institut für Technische Gebäudeausrüstung Dresden  
Forschung und Anwendung GmbH

Prof. Oschatz – Dr. Hartmann – Dr. Werdin – Prof. Felsmann

## Praxisnahe Variantenuntersuchungen zum BEKOTEC-THERM Keramik Klimaboden

Auftraggeber: Schlüter Systems KG  
Bereich Anwendungstechnik  
Herr Karl-Friedrich Westerhoff  
Schmölestraße 7  
58640 Iserlohn

Auftragnehmer: ITG Institut für Technischen Gebäudeausrüstung Dresden  
Forschung und Anwendung GmbH  
Bayreuther Straße 29 in 01187 Dresden

Bearbeitung: Dr.-Ing. habil. J. Seifert  
Dipl.-Ing. Andrea Meinzenbach  
Dr.-Ing. A. Perschk  
Dr.-Ing. M. Knorr  
Prof. Dr.-Ing. B. Oschatz

Dresden, 26.11.2012

iTG

Institute for Building Systems Engineering Research

# Ceramic thermal comfort floor

## Thermal comfort

### A step ahead in thermal comfort

The Schlüter-BEKOTEC-THERM ceramic thermal comfort floor is a system that sets new standards of comfort. The heating advantages of the system provide higher quality of living in every room. Due to the large scale, unobtrusive heat transfer with low system temperatures in conjunction with quick control responses of the system, the entire house offers a previously unknown level of comfort. The perceived room temperature is significantly higher. As a consequence, the actual room temperature can be lowered by approx. 1 - 2 °C without any change in comfort. This in turn leads to lower energy needs and reduces heating costs.

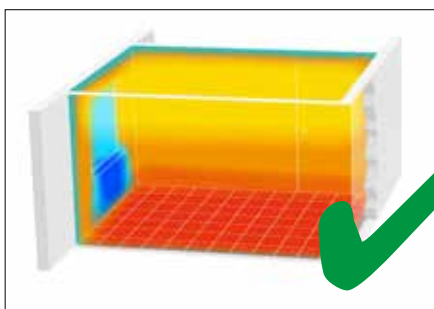

Ceramic thermal comfort floor with *even* heat distribution

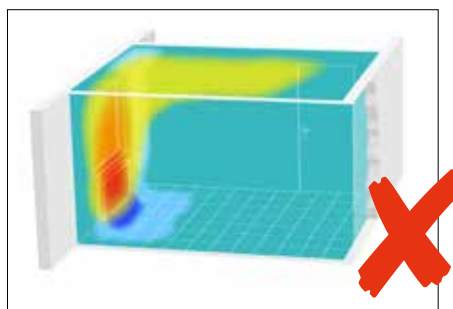

Radiator heating system with *uneven* heat distribution

### Better hygiene and health

The high share of radiated heat in floor heating systems reduces air movement, and consequently is associated with less dust. Additionally, the heat removes moisture from the warm surfaces and makes it more difficult for bacteria and mould to survive.

The healthcare system discovered the advantages of floor heating systems long ago. Treatment rooms, operating rooms and sanitary rooms are increasingly equipped with floor heating systems, which are easy to keep sterile.

### Higher safety with dry ceramic coverings in bathrooms and indoor swimming pools

Cleaning measures or moisture caused by space utilisation reduces the anti-slip properties of ceramic coverings.

However, when these areas are heated with a ceramic thermal comfort floor system, they dry quickly. This prevents a possible slip hazard.

### Design without limits

Clear room design without the intrusion of heating elements, for example along walls or under windows, opens up a large spectrum of design options. There are no limits to using and designing living, working, and showroom areas.



# Ceramic thermal comfort floor

## Areas of application

The Schlüter-BEKOTEC-THERM ceramic thermal comfort floor is an easily assembled, safe system with low construction height and short installation times for new buildings, renovation projects, exhibition halls, bathrooms and swimming pool surrounds, etc.

As a result, the application areas of the BEKOTEC-THERM ceramic thermal comfort floor are especially versatile. The construction advantages and thermal technology benefits of the system can be used for customised applications in the following areas.

### New construction

The quick installation of the entire ceramic thermal comfort floor system saves time and cost. This is made possible by installing the uncoupling mat Schlüter-DITRA, DITRA-HEAT or DITRA-DRAIN 4 in conjunction with ceramic tile or natural stone coverings as soon as the screed is ready to bear weight. The system does not require any functional heating or curing after interface assembly, as is customary with conventional heated floor constructions.

Due to the low screed mass, the ceramic thermal comfort floor has heating and cooling properties that respond quickly to thermostat adjustments.

The effective heating performance and low supply temperature of the ceramic thermal comfort floor in addition to conventional heating systems allows for the use of modern heating technology and regenerative energies, such as heat pumps and solar heating systems. The ceramic thermal comfort floor even allows for passive cooling in the summer.

The low construction height of Schlüter-BEKOTEC-THERM enables compliance with low construction height specifications.

This means:

- Additional depth available for installing insulation materials to comply with **required insulation values** or
- **Improved insulation values** by installing additional insulation materials.

### Renovation

Conventional floor heating systems with screed coverings of at least 45 mm over the heating pipes can weigh 130 kg/m<sup>2</sup> or more. For renovation projects, the following are essential:

low weight (static concerns) and low assembly height. For this reason, the installation of the Schlüter-BEKOTEC-THERM ceramic thermal comfort floor is feasible even when a conventional floor heating system has to be ruled out. Even lower assembly heights from 20 mm to the top edge of the screed can be achieved with the studded screed panel Schlüter-BEKOTEC-EN 12 FK. For the BEKOTEC-EN 12 FK system with a screed cover of 8 mm, the volume weight to be considered is just 40 kg/m<sup>2</sup> (also see table on page 32).

If sound insulation is required, the studded screed panel Schlüter-BEKOTEC-EN 18 FTS with its integrated sound insulation layer is a potential solution.

### Sales areas and car showrooms

The load bearing capacities of the thin layer Schlüter®-BEKOTEC-THERM ceramic thermal comfort floor has proven its lasting value in many large-scale reference projects. The regular patterns of the Schlüter-BEKOTEC studded panel evenly reduce tensions in the screed, which allows for constructing the screed without joints. The free arrangement of movement joints in the joint pattern of the ceramic covering, therefore, allows for a great variety of design options.

### Wet areas

Schlüter-DITRA, DITRA-HEAT and -KERDI are certified bonded waterproofing assemblies for wet areas of classes 0–B0 in accordance with the ZDB information and for the load classes A and C in areas requiring German construction permits. Consequently, these systems are particularly suitable for use in bathrooms, swimming pools and other areas with high moisture loads (see *product data sheets 6.1, 6.4 and 8.1*). The systems are also ideal for the safe and quick installation of barrier free bathrooms with level shower cubicles (see *product data sheets 8.2 and 8.6; point drainage or 8.7 and 8.8; linear drainage*).



# Ceramic thermal comfort floor

## Thermal properties

The construction advantages and the cooling and heating benefits of Schlüter-BEKOTEC-THERM are most pronounced in conjunction with ceramic tile and natural stone coverings. A mean heating water temperature of 30 °C is sufficient for the ceramic thermal comfort floor in most well insulated buildings. In addition to conventional heating systems, the ceramic thermal comfort floor can therefore be effectively operated with state-of-the-art heating technology such as condensing boilers and regenerative sources of energy, such as heat pumps and solar systems. The performance comparison shown below clearly highlights the thermal advantages of the **ceramic thermal comfort floor**.

## Practical performance comparison of ceramic coverings and thick carpeting/parquet

### Ceramic

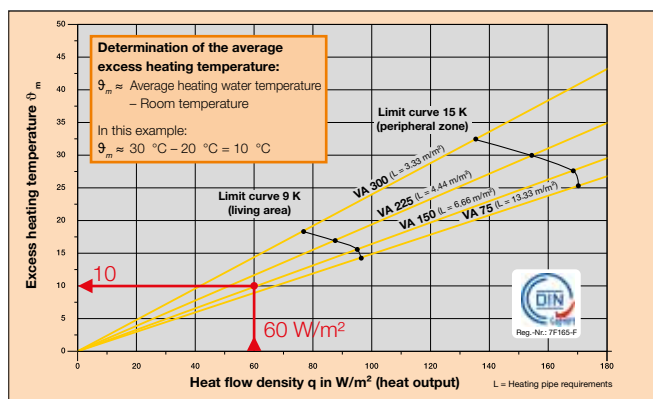

### Thick carpet/parquet ( $R_{\lambda, \max} = 0.15 \text{ m}^2 \cdot \text{K/W}$ )

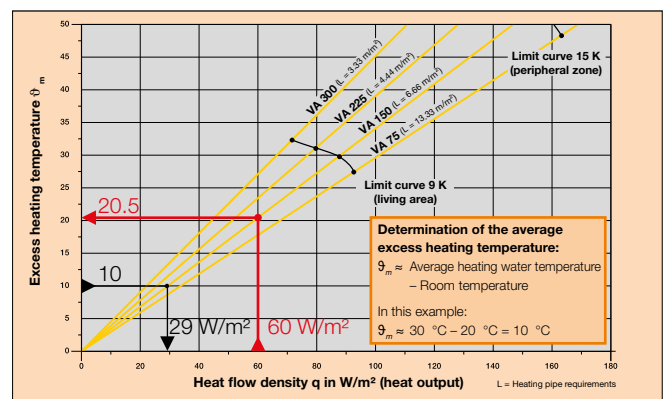

The exact performance data from the thermal test of the system are allocated to the corresponding system.

### i

#### Conclusion

This sample calculation shows that carpet and hardwood floors reduce the heating performance by 50% compared to a ceramic thermal comfort floor because of their unfavourable thermal resistance factors.

## Ceramic thermal comfort floor Schlüter®-BEKOTEC-THERM

### Example: Schlüter-BEKOTEC-EN P or PF with heating pipe Ø 16 mm

A heat output of 60 W/m<sup>2</sup> was assumed for a room temperature of 20 °C. The heating pipe installation spacing VA was 150 mm.

Moving vertically up to the intersection of the output line of the installation spacing VA 150 with the desired output of 60 W/m<sup>2</sup>, the left scale shows the corresponding excess heating temperature for the ceramic thermal comfort floor as 10 °C.

This excess heating temperature means that the heating water on average has to be 10 °C warmer than the desired room temperature to stay at the output level of 60 W/m<sup>2</sup>.

The average heating water temperature is calculated as follows:

10 °C excess heating water temperature ( $\theta_m$ ) + 20 °C room temperature = **30 °C average heating water temperature**.

### Schlüter-BEKOTEC-THERM and carpet ( $R_{\lambda, \max} = 0.15 \text{ m}^2 \text{ K/W}$ )

Under the same conditions, an average heating water temperature of 40.5 °C is required for an output of 60 W/m<sup>2</sup> when carpet is used with a thermal resistance of  $R_{\lambda, \max} = 0.15 \text{ m}^2 \text{ K/W}$ . This is the equivalent of an excess heating temperature of about 20.5 °C in the diagram.

If the average heating water temperature is left at 30 °C, the heat output falls to approx. 29 W/m<sup>2</sup>.



# Ceramic thermal comfort floor

## Thermal properties

### Heat distribution function

The fast heating of the system with low screed coverage highlights the excellent thermal conductivity of ceramic coverings. This is documented anhand der thermal technology test of the independent Laboratory for Process Technology at Darmstadt University.

The heat radiation and convection processes in the interconnected air channels of Schlüter-DITRA/-DITRA-PS provide additional heat distribution and ensure an even surface temperature.

The low screed coverage achieves maximum heating performance with low supply temperatures (see also performance diagrams of the respective BEKOTEC system studded screed panels).

## Thermographic analysis of heating response and heat distribution with Schlüter-DITRA

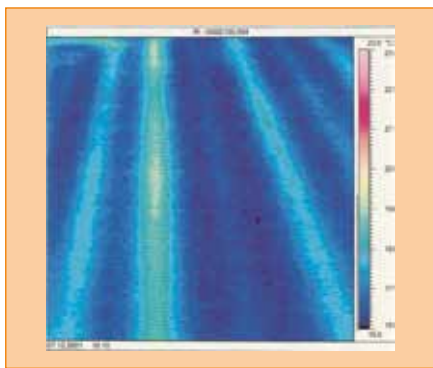

1 Start of heating phase with a surface temperature of 16 °C. The picture was taken after 10 minutes of system operation. Average surface temperature above the heating pipe: 18.5 °C.

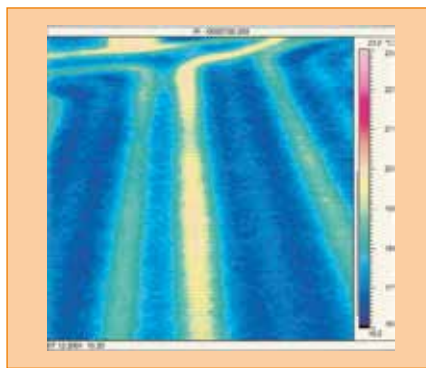

2 The picture was taken after 20 minutes of operation. Average surface temperature above the heating pipe: 19.5 °C. The heat distribution within the uncoupling mat Schlüter-DITRA shows first temperature increases between the heating pipes.

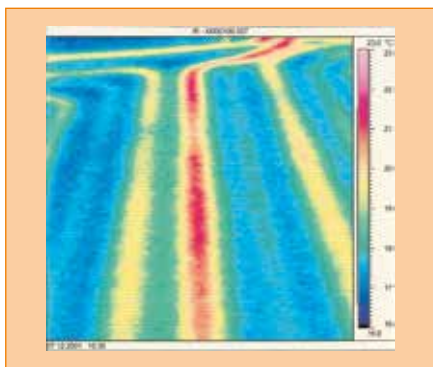

3 The picture was taken after 30 minutes of operation. Average surface temperature above the heating pipe: 21 °C. The heat distribution within the uncoupling mat Schlüter-DITRA shows a clear temperature increase between the heating pipes.

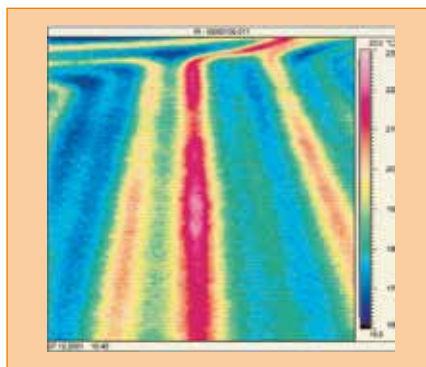

4 The picture was taken after 40 minutes of operation. Average surface temperature above the heating pipe: 22.5 °C. The heat distribution within the uncoupling mat Schlüter-DITRA provides an even surface temperature and low heat fluctuations.



### Summary

- Very little temperature fluctuation between the heating pipes
- Quick combination of surface temperatures between the heating pipes
- The requirements of the German Buildings Energy Act (GEG) for fast reacting systems are met
- The ceramic thermal comfort floor is fast and easy to regulate, leading to energy efficient control

## Ceramic thermal comfort floor

### Renewable sources of energy and modern energy technologies

Modern energy generators for heating and cooling buildings allow for an economic use of fossil fuels and the use of regenerative energy sources (such as geothermal energy). The potential of the energy and cost savings, with the associated reduction in CO<sub>2</sub> emissions, can be maximised when the system temperature of a heating system is as low as technically feasible. Additionally, the corresponding control technology must be adapted to these conditions to avoid supply losses and unnecessary room temperature fluctuations.

The Schlüter-BEKOTEC-THERM ceramic thermal comfort floor features low system temperatures and is ideally suited for utilising geothermal energy (heat pumps), solar energy, and condensing boiler technology.

#### Heat pumps and Schlüter-BEKOTEC-THERM

Energy is available in large quantities in the air, the groundwater and the soil. By using a negligible amount of electric energy to operate the heat pump, the temperature can be increased to reach sufficient system temperatures. The larger the temperature difference between the heat source (air, soil or groundwater) and the intended system temperature, the more energy is required for operating the heat pump.

It follows from this principle that the effectiveness (output factor) of a heat pump increases when the temperature difference between the heat source (environment) and the heating system decreases. The output factor is the ratio of utilised power and generated heat.

#### The low supply temperatures of the BEKOTEC ceramic thermal comfort floor have the following advantages:

- Reduced use of energy (electric power) to operate the heat pump
- Improved output factor, and consequently, larger energy utilisation over the entire heating period
- Faster payback

The Schlüter-BEKOTEC-THERM ceramic thermal comfort floor improves the energy utilisation of heat pumps.

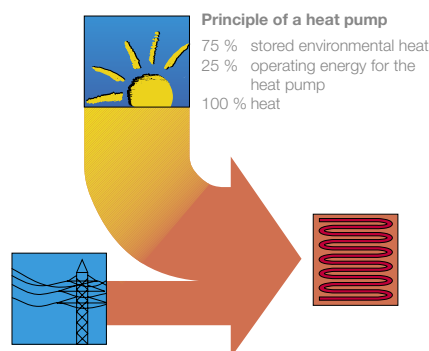

Source: Bundesverband Wärme Pumpe (BWP) e.

i

#### Guiding principle for using geothermal heat, solar energy, and condensing boiler technology

All of these systems have one factor in common: the lower the system temperature for covering the required heating load, the more efficient the use of the energy.



# Ceramic thermal comfort floor

Renewable sources of energy and modern energy technologies

## Solar technology and Schlüter-BEKOTEC-THERM

The energy effectiveness of solar systems that are integrated into heating systems increases with every degree the system temperature can be lowered. On sunny days, a properly designed solar system can cover or support the heating system.

The BEKOTEC-THERM ceramic thermal comfort floor improves the energy utilisation of solar systems.

Consequence:

- Lower supply temperatures can be used to heat floor areas.
- The energy effectiveness increases. This leads to a higher energy usage factor over the entire heating period.
- The payback period of the system is shorter.

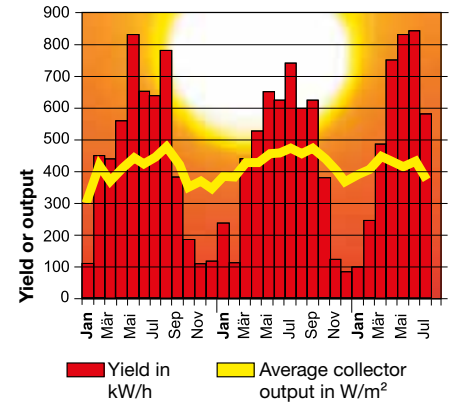

Output/yield over 2 heating periods

## Condensed boiler technology and Schlüter-BEKOTEC-THERM

The increase of energetic efficiency in these devices relies on the utilisation of latent heat contained in the water vapour of smoke gas (energy gain by partial condensation).

The water vapour is the result of burning natural gas and oil. With the use of conventional low temperature heating boilers, the heat contained in emissions gas typically is released to the environment, together with water vapour. Condensed boiler technology is able to condense the water vapour of the emissions flow in a heat exchanger and derive additional heating energy even after the combustion process. This effect can only be utilised efficiently with low return temperatures.

The BEKOTEC-THERM ceramic thermal comfort floor improves the energy utilisation of condensed boilers with low system temperatures.

# Ceramic thermal comfort floor

## Cooling with heat pumps

Cooling technology keeps gaining importance, especially in the summer months. Heating systems with heat pumps commonly offer an easily accessible cooling function that is particularly economical and energy efficient. Such systems require a floor heating system that absorbs the heat. A distinction is made between active and passive cooling.

### Passive cooling function in systems with heat pumps

A passive cooling system uses heat pumps with ground collectors or depth drillings (also called natural cooling). This is made possible by the fact that the ground temperature is much lower than the temperature of living spaces in the summer. With passive cooling, the heat pump operates in cooling mode with the compressor turned off. Many systems include a corresponding bypass valve in their cooling circuit. Based on the recirculation of the heating medium, the heat in the living space is absorbed by the quick reacting Schlüter-BEKOTEC-THERM floor heating system and transferred into the cooler ground. In this manner, a floor heating system can be used efficiently and without high energy consumption for environmentally friendly cooling. The process also leads to slight warming of the soil, which increases the efficiency of the heat pump in heating mode.

The system can be controlled with a thermostat that has a cooling function.

Passive cooling creates pleasant indoor temperatures during the summer months. Although the cooling performance does not compare to conventional air conditioning units, it reduces room temperatures sufficiently to generate comfortable indoor conditions. The below diagram shows that shifting the ambient temperature and the temperature of surrounding surfaces (such as the floor) by just a few degrees Celsius can make a big difference in perceived comfort.

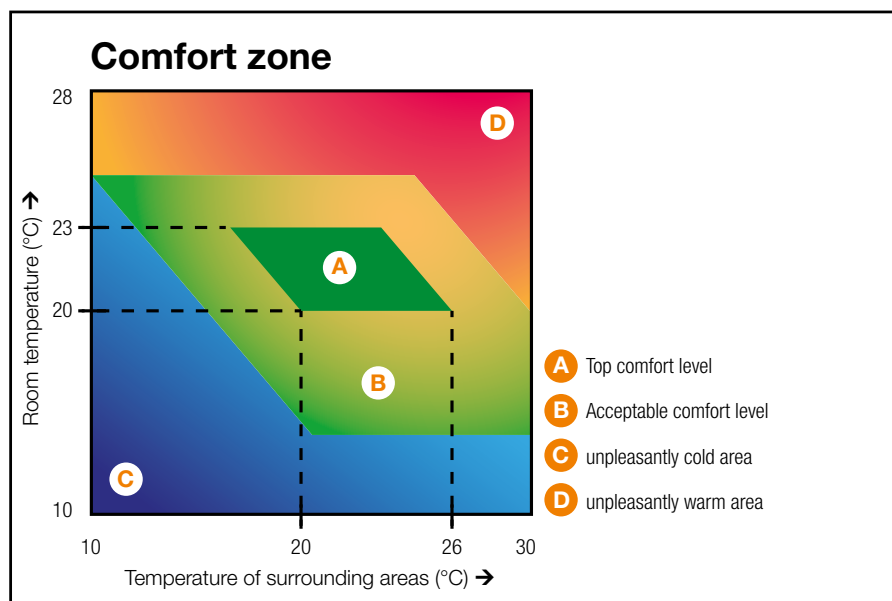
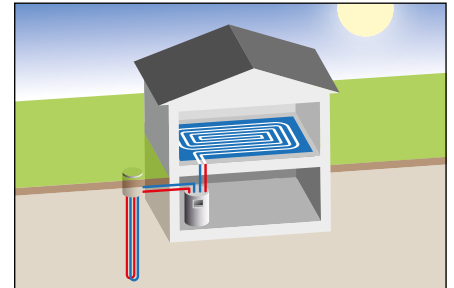

### Active cooling function in systems with heat pumps

In the case of active cooling, for instance with air-water heat pumps, the cooling performance of the heat pump is transferred to the heating system. Since the heat pump compressor is turned on, the heat pump is "active". That means the power consumption is higher than with passive cooling. Depending on the heat pump, active cooling can achieve greater cooling performance. Further performance diagrams can be found with the respective BEKOTEC panel.

### Notes

Schlüter-BEKOTEC-THERM floor heating systems are ideally suited for heating and cooling because their thin layer screed assemblies are highly responsive. That also allows for a quick switch to heating after a cooling period.



## Cooling performance of Schlüter-BEKOTEC-THERM systems

The cooling performance of Schlüter-BEKOTEC-THERM systems depends on the top covering. Ceramic coverings achieve the best cooling and heating values.

The performance data of the various BEKOTEC-THERM systems determined in accordance with DIN EN 1264 show that ceramic coverings can achieve average cooling values of 30 - 40 W/m<sup>2</sup>. This lowers the room temperature by approx. 3 °C.

The following performance data were determined for the BEKOTEC-THERM systems in W/m<sup>2</sup>, based on the installation spacing VA and the temperature difference  $\Delta T$  (room temperature - cooling water temperature) according to DIN EN 1264. Cooling water temperatures are commonly around 18 °C.

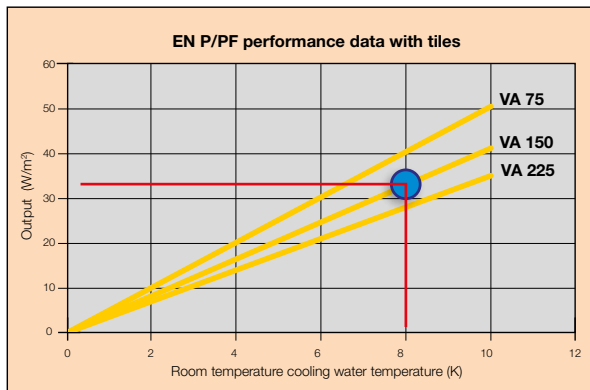

### Example:

Room temperature: 26 °C

Cooling water temperature from heat pump: 18 °C

$\Delta T = 26 \text{ °C} - 18 \text{ °C} = 8 \text{ K}$

Result: cooling performance with VA 150: 34 W/m<sup>2</sup>

## Ceramic thermal comfort floor

### Non buckling, thin layer covering assembly

The reliable Schlüter-BEKOTEC covering assembly technology is a system for functionally safe, floating screeds and heated screeds. This enables crack-free coverings made of ceramic, natural stone and other covering materials. These systems are based on studded screed panels that are directly installed on top of load bearing substrates or conventional heat and/or sound insulation panels. The studs are designed to hold the heating pipes of the system in a grid pattern of 50 mm (with BEKOTEC-EN 12 FK/-EN 12F PS and BEKOTEC-EN 18 FTS) or 75 mm (with BEKOTEC-EN/P or -EN/PF and BEKOTEC-EN FI 30/-23F/-23F PS) in order to create heated screeds. The studded screed panel BEKOTEC-EN 12 FK/12F PS must be directly adhered on the load bearing substrate. The studded screed panels BEKOTEC-EN/P or -EN/PF, and BEKOTEC-EN FI 30/-23F/-23F PS and BEKOTEC-EN 18 FTS with 5 mm sound insulation on the underside, are installed loosely on the load-bearing substrate or suitable insulation.

Since only a relatively small amount of screed has to be heated or cooled, the floor heating system is easily adjustable and can be operated at low temperatures. The studded grid helps reduce the tension that occurs in the curing screed and ensures that the screed does not curl as a result of shearing tensions due to contraction buckling. It is therefore not necessary to install joints in the screed.

Once the cement screed is ready to support weight, the uncoupling mats Schlüter-DITRA, DITRA-HEAT or DITRA-DRAIN 4 can be installed (screeds based on calcium sulphate with a residual moisture content of  $\leq 2$  CM-%). The ceramic tiles or natural stone are then installed directly over this layer, using the thin bed method. Movement joints in the covering layer have to be created with Schlüter-DILEX in the customary spacing. Covering materials that are not susceptible to cracking, such as parquet, vinyl, laminate or carpeting, can be directly installed over the screed as soon as it reaches the corresponding residual moisture level.

The notes on the requirements for insulation and joint design on *pages 28, 30, 31 and 33* must be observed.

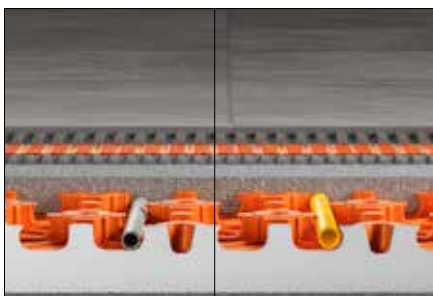

Schlüter®-BEKOTEC-EN 23 FI 30

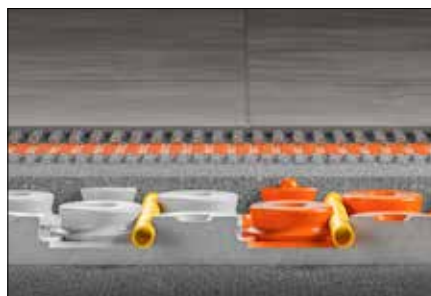

Schlüter®-BEKOTEC-EN/P (-EN/PF)

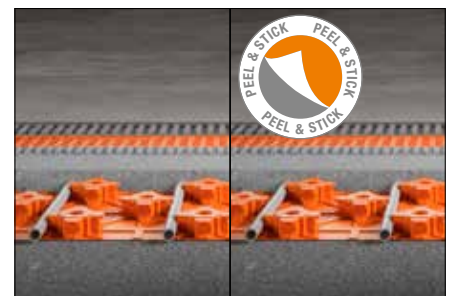

Schlüter®-BEKOTEC-EN 23 F self-adhesive  
Schlüter®-BEKOTEC-EN 23 F PS



Schlüter®-BEKOTEC-EN 18 FTS with pre-adhered  
sound insulation



Schlüter®-BEKOTEC-EN 12 FK



Self-adhesive Schlüter®-BEKOTEC-EN 12 F PS



## Ceramic thermal comfort floor

### Traffic loads

#### Car dealerships, exhibition halls and lobbies with higher traffic loads

The load bearing capacities of the thin layer Schlüter-BEKOTEC structures have proven their lasting value in many large-scale sales and exhibition spaces, and particularly in car dealerships.

When selecting ceramic floor coverings for the anticipated stresses, determine the material thickness with the help of the information sheet "Coverings with high traffic loads".

Impact resistant DEO insulation is presumed as substructure insulation for the use of our system panels Schlüter-BEKOTEC-EN/P, -EN/PF or -EN 23 F, -EN 23 FPS and -EN23 FI 30. These must be selected by the architect.

In principle, the design depends partially on the load transfer of the substructure.

i

#### Note:

Higher traffic loads may be approved as part of a special agreement if applicable. For this purpose, we need to know the exact structure of the floor assembly with heights and additional insulation taken into account, including the corresponding designations or labels. For this application, the screed cover should be increased to 15 mm if applicable (*see also the table on the following page*).

For further information, please contact our Technical Department.



# Ceramic thermal comfort floor

## Traffic loads

Schlüter®-BEKOTEC-THERM				
Minimum screed coverage for various traffic loads and surface coverings				
Floor covering	Max. traffic load Qk according to DIN EN 1991	Max. individual load* Qk according to DIN EN 1991	Recommended min. system coverage with conventional screeds	Usage category/application areas according to DIN EN 1991
Ceramic tile/natural stone	5.0 kN/m <sup>2</sup>	3.5 - 7.0 kN	8 mm	to C3 e.g. exhibition spaces, access areas in public and administrative buildings, hotels, hospitals, train stations
Loose or bonded soft coverings: PVC, vinyl, linoleum, carpet, cork	2 kN/m <sup>2</sup>	2.0 - 3.0 kN	15 mm	A Residential buildings, nursing stations and patient rooms in hospitals as well as in hotel and hostel rooms
Adhered parquet without tongue	5.0 kN/m <sup>2</sup>	3.5 - 7.0 kN	15 mm	to C3 e.g. exhibition spaces, access areas in public and administrative buildings, hotels, hospitals, train stations
Adhered parquet with tongue and groove connection	5.0 kN/m <sup>2</sup>	3.5 - 7.0 kN	8 mm	to C3 e.g. exhibition spaces, access areas in public and administrative buildings, hotels, hospitals, train stations
Floating parquet, laminate and coverings with click system	2 kN/m <sup>2</sup>	2.0 - 3.0 kN	8 mm	A Residential buildings, nursing stations and patient rooms in hospitals, hotel and hostel rooms

\* The contact area of individual loads must be adapted to the BEKOTEC structure with surface covering and to the static prerequisite of the ceiling structure.

## Maximum system coverage with conventional screeds

BEKOTEC studded screed panel	EN 23 FI 30	EN P/EN PF	EN 23F	EN 23 F PS	EN 18 FTS	EN 12 FK	EN 12 F PS
Maximum coverage	25 mm	25 mm	25 mm	25 mm	20 mm	15 mm	15 mm

**Max. permissible height compensation values:** For height adjustment purposes and levelling in some areas, the thickness of the screed may be increased to the specified maximum value over the studs. However, the overall height of the screed over the studs should be within the minimum coverage of 8 mm or 15 mm.

### Note:

The Schlüter-DITRA uncoupling mats must be used for the installation of ceramic tile and natural stone coverings.



# Prerequisites and implementation

## Installation instructions, general requirements

### Structural requirements

For the installation of a Schlüter-BEKOTEC-THERM ceramic thermal comfort floor, the windows of the building must be fully installed and closed or the openings must be temporarily closed. The interior walls must be finished. The impact of frost must be prevented with suitable measures. The height measurements must be clearly marked in all rooms and must match the planned floor assemblies.

#### Protection from floor moisture and non-pressurised water

Construction engineers must select a waterproofing barrier against non-pressurised water and floor moisture (capillary moisture). Waterproofing must be professionally installed on site.

### Preparing the substrate

The load bearing substrate must meet the static requirements for supporting the floor construction and the intended traffic load (DIN/BS EN 1991). According to DIN 18 560-2, Section 4, the load bearing substrate must be sufficiently dry to support the construction system and have a level surface according to the measurement tolerances in buildings (DIN 18 202). This includes humps and hollows, point shaped high spots and mortar residue. The required floor slope and levelling measures must evenly distribute the load on the substrate and must be dimensioned in such a way that the screed can be applied in an even thickness.

**The studded screed panels EN 12 FK/EN 12 F PS are installed only on fully load bearing substrates, not insulation layers!**

#### Pipes, cables and cable routes on the structural concrete base

Unfortunately, pipes and cables on concrete bases are a frequent occurrence at construction sites. This should be avoided with proper planning. If pipes are installed on the load bearing substrates, suitable levelling measures must be taken to create a level, load bearing installation area.

The available methods include levelling mortar and screed, pressure resistant heat insulation or adding bound fill, such as Thermowhite, that is approved for use under screeds and capable of absorbing the required loads.

**Note:** As a general rule, loose fill may not be used for levelling purposes under floating screed constructions.

If it cannot be avoided, pipes and cables may be installed on the concrete base, but must be installed as straight as possible, without intersections, and must be parallel to the rising walls.

#### Please note:

4.6 Information on the planning and installation of floor constructions for pipes, cables and structural components on raw ceilings, published by the Central Association of the German Construction Industry.

### Dimensions from the guideline

- A:** Routing width of parallel lines, including pipe insulation: **max. 300 mm**
- B:** Fully load bearing width between the routes **min. 200 mm**
- C:** Distance between walls and upright construction elements **min. 200 mm**

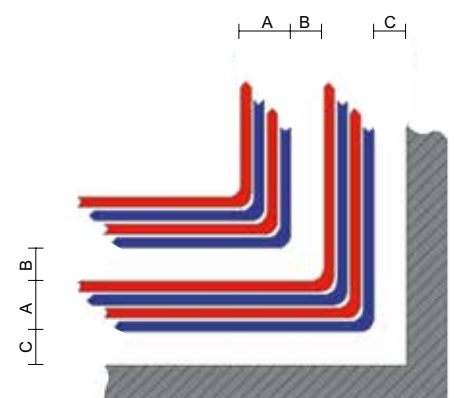

#### Note:

Minimum distance from door frames: 150 mm

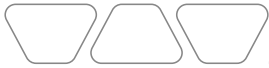

## Prerequisites and implementation

### Preparing the substrate

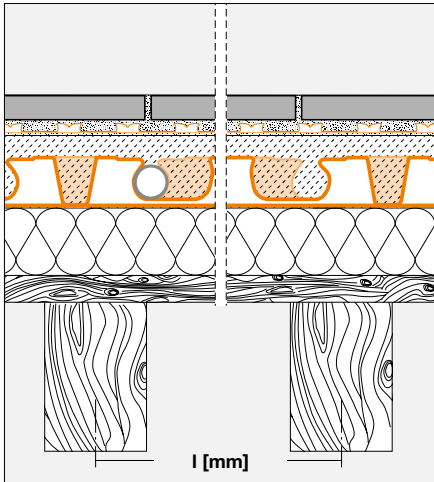

The studded screed panels EN 12 FK, -EN 12F PS are installed exclusively on fully load bearing substrates – not over insulation layers.

#### Schlüter-BEKOTEC-THERM over wooden floor assemblies

Special preparatory work may be necessary for installing a Schlüter-BEKOTEC-THERM system over a wooden floor assembly. The wooden floorboards or plywood panels must be firmly screwed to the substructure to completely rule out any flexing of the elements at the abutting joints of the floorboards or panels. The entire structure must be sufficiently load bearing to guarantee low vibration use. The maximum deflection may not exceed  $l/300$ . This deflection refers to the distances of the supports/beams and to entire support span of the ceiling.

#### Example: Beam spacing: 750 mm

$750 \text{ mm} / 300 = 2.5 \text{ mm}$  max. deflection between beams (joists)

#### Ceiling support span: 3000 mm

$3000 \text{ mm} / 300 = 10 \text{ mm}$  max. deflection over a ceiling support span of 3 meters

### Movement joints in the load bearing substrate

Structural joints in the load bearing substrates may not be covered by heating elements. These joints must be continued to the floor covering.

The following Schlüter system components are available for establishing joints in the surface covering:

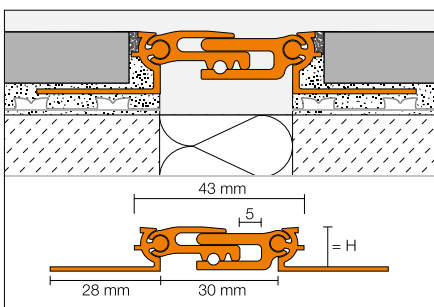

Schlüter-DILEX-BT is a structural expansion joint made of aluminium with a lateral joint connection of the interlocking centre section. This allows for the absorption of three-dimensional movement (see product data sheet 4.20).

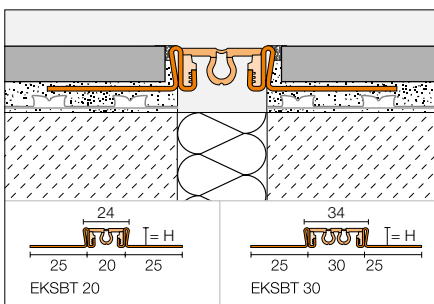

Schlüter-DILEX-KSBT is a structural movement profile with edge protection, consisting of side anchoring legs of aluminium or stainless steel connected to a 20 mm or 30 mm wide movement zone of soft synthetic rubber (see product data sheet 4.19).

## Prerequisites and implementation

### Requirements for additional heat and sound insulation



Installation of heat and/or sound insulation on a sufficiently load bearing and level substrate.



Schlüter®-BEKOTEC-BTS  
(max. traffic load: 2 kN/m<sup>2</sup>)

The minimum insulation requirements and thicknesses must be determined according to DIN-EN 1264 (BS-EN 1264), "Hot water underfloor heating systems," DIN 4108-10, "Thermal insulation and energy economy in buildings - Application related requirements for thermal insulation materials," DIN 4109, "Noise control in buildings," as well as the applicable regulations according to the Buildings Energy Act (GEG). The insulation layer must be suitable for the required traffic loads. The utilised insulation materials must be approved for installation below floating screeds.

Labelling of approved insulation materials:

DEO - insulation below screeds **without** sound insulation requirements

DES - insulation below screeds **with** sound insulation requirements

Insulating layers are installed as a continuous layer with abutting joints. In the case of dual layer insulation, the joints must be staggered. The insulation layer must have full contact with the substrate. Hollow spots must be eliminated with suitable measures.

If both sound insulation and heat insulation panels are used, the insulation material with the lower compressibility factor should be on top. If the lower heat insulation layer is used, against the advice of standard regulations, to offset the height of installed pipes, the sound insulation must be on top in a consistent area.

#### Note on Schlüter-BEKOTEC-THERM:

- The studded screed panels EN 12 FK / 12 F PS are installed exclusively on fully load bearing substrates – not over insulation or separating layers.
- Only one layer of sound insulation is permissible, with a maximum compressibility of CP 3 ( $\leq 3$  mm).
- The compressive strength of the entire structure may not exceed a value of 3 mm.

#### Tip: Impact sound and refurbishment

If the construction height does not allow for using polystyrene or mineral fibre insulation, the Schlüter-BEKOTEC-BTS sound insulation membrane (thickness: 5 mm) can achieve significantly improved sound insulation in conjunction with ceiling construction.

*For further information about Schlüter-BEKOTEC-THERM with drawings of insulation materials, please refer to pages 153 - 156.*

## Separating layer



Installation of separating layer

If using flowing screed, we recommend the installation of a PE protective foil on top of the insulation layer or bound fill (thickness min. 0.15 mm) with overlaps of 8 cm prior to installing the Schlüter-BEKOTEC-EN 23 FI 30, -EN 1520 PF or -EN 23 F studded screed panel. This prevents the flowing screed from seeping behind the BEKOTEC panels.



# Prerequisites and implementation

## Edge strips and edge joints







Sample installation of the edge strip BRS 810 or BRSK 810 with integrated foil leg

Edge strips are used to form the edge joints in order to provide the movement accommodation required according to DIN 18560. Edge joints are movement joints that delimit the screed along walls and floor penetrating construction elements, such as columns. They reduce impact sound transmission and absorb the expansion changes of the floor assembly caused by thermal factors. Additionally, they prevent shearing tensions in the screed and in the surface covering. Edge joints must not be filled.

**Note:**

Make sure that no amount of tile adhesive, levelling compound, or grout can get into the edge joints. The edge joint profile Schlüter®-DILEX-EK (see below) are ideally suited for this purpose.

The edge strips must be installed prior to fitting the Schlüter-BEKOTEC studded screed panels. The strip must run continuously along all rising construction elements and be secured against moving.

Schlüter®-BEKOTEC-THERM Allocation of the matching system edge strips						
		EN 23 F130 EN 2520 P*	EN 1520 PF	EN 23 F EN 23 F PS	EN 18 FTS	EN 12 FK EN 12 FK PS
	<b>BRS 810</b> for traditional semi-dry screeds only	X				
	<b>BRSK 810</b> for traditional semi-dry screeds only	X				
	<b>BRS 808 KF</b> for traditional semi-dry screeds and flowing screeds	X	X			
	<b>BRS 808 KSF</b> for traditional semi-dry screeds and flowing screeds	X	X	X	X	X

To be used for traditional semi-dry screeds only.



Schlüter®-DILEX-EK

Depending on the final surface covering, the edge strip is cut off at the end of the floor installation work or prior to the installation of the flexible Schlüter-DILEX-EK or -RF edge joint profiles. Schlüter-Systems offers a wide variety of Schlüter-DILEX profiles for creating maintenance free and safe edge and movement joints at the transition of floor and wall or skirting tiles.

For more information, see [product data sheet 4.14, Schlüter-DILEX-EK/-EF](#).

## Prerequisites and implementation

### Joints in the Schlüter®-BEKOTEC system



Regardless of the floor covering, conventional screeds must be divided into fields of specific sizes with movement joints. This labour intensive division of screed fields and the associated need to coordinate with other tradesmen is not necessary when building a Schlüter-BEKOTEC system.

Any contraction occurring while the screed cures is absorbed by the studded pattern of the BEKOTEC studded panels. As a consequence, a BEKOTEC screed is not subject to contraction buckling over its entire area. It is therefore not necessary to install joints in the screed.

If any joints (e.g. a daywork joint) in the screed result from necessary work interruptions, these must be protected against height discrepancies, covered with resin, or turned into an expansion joint in the covering.

#### Exceptions

- See page 28: Movement joints in the load bearing substrate.
- To avoid sound bridges and in the case of height differences in the substrate, the screed should be separated, for example, at door transitions.

We recommend the use of Schlüter-DILEX-DFP expansion joint profiles for door transition areas (a height offset mechanism may need to be installed if applicable). Thanks to the bilateral coating and the self-adhesive strip, straight line installation is very easy.

If no impact sound insulation is required, only a joint under the door area is recommended. This joint must be continued into the covering as a movement joint.

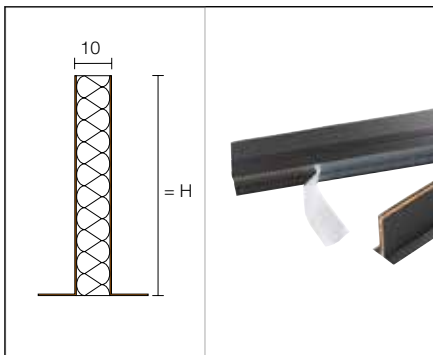

Schlüter®-DILEX-DFP

## Prerequisites and implementation

### Installation of screeds based on conventionally applied cement or gypsum screeds



Prior to installing the screed, the seal of the heating system must be tested under pressure. However, the system may not be heated during the installation and curing process of the screed (see p. 170).

For further information on filling and venting and a pressure test report, please refer to the Appendix. If the residual moisture of the screed has to be measured, the corresponding measuring points must be set up in the screed (For the measurement report, see p. 172.).

As part of the screed installation, fresh cement-based or gypsum-based screed is installed with a minimum screed cover of 8 mm over the studded panels (recommended aggregate size 0-4 mm). A compressive strength of C20 to C35, as well as a flexural tensile strength of F4, max. F5, must be maintained for both cement- and gypsum-based screeds. If the cement has a shrinkage class of SW1, using products with a higher flexural tensile strength is also possible. Further information about the installation of screeds with a higher flexural tensile strength or other technical properties is available from our Technical department on request.

Flowing screeds **CAF/CTF** with the corresponding specifications may be used as well. Observe the system approval for this application.

For height adjustment purposes and levelling in some areas, the thickness of the screed may be increased to the specified maximum value over the studs. However, the overall height of the screed over the studs should be within the minimum coverage of 8 or 15 mm (see table "Traffic loads", page 25).

The screed quality must follow the specifications of DIN EN 13 813 (BS EN 13 813). The applicable installation instructions must be observed. The heating pipes must be carefully embedded in the screed mortar.



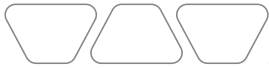

## Screeds for BEKOTEC systems

The most important abbreviations for screeds used with BEKOTEC systems are:

### Types of screed

- **CT** Cement screed
- **CA** Gypsum based screed (anhydrite screed)
- **CTF** Cement tile screed
- **CAF** Gypsum based tile screed

### Screed properties

- **C** Compression, e.g. C25 means pressure impact resistance of 25 N/mm<sup>2</sup>
- **F** Flexural strength, e.g. F4 has a flexural strength of 4 N/mm<sup>2</sup>

Schlüter®-BEKOTEC screed volumes for a minimum coverage of 8 mm			
Studded panel	Min. screed coverage mm	Area weight* kg/m <sup>2</sup>	Screed volume* l/m <sup>2</sup>
EN 23 FI 30	8	58	28.5
EN/P, EN P/PF, EN 23 F, EN 23 F PS	8	57	28.5
EN 18 FTS	8	52	26
EN 12 FK, EN 12 F PS	8	40	20

\* For screed density of approx. 2000 kg/m<sup>3</sup>.

The following calculation basis applies for additional screed coverage > 8 mm whatever the selected BEKOTEC system: 1 mm/m<sup>2</sup>  $\triangleq$  2 kg/m<sup>2</sup>  $\triangleq$  1 l/m<sup>2</sup>.



### Don't use reinforcement or screed additives

No reinforcement or screed additives. Any "non static reinforcement" of the screed or heated screed to be poured is neither required for the system nor permissible.

Similarly, additives or fibres that increase the flexural strength of the Schlüter-BEKOTEC screed are superfluous and not permissible.

In fact, the reinforcement with fibres and rebar mats or the use of additives to increase flexural strength may actually counter the modular reduction of tension in the screed that occurs in the stud patterns of the BEKOTEC studded panel.

## Additional system products for ceramic tiles and natural stone

### Installation of Schlüter-DITRA uncoupling mats

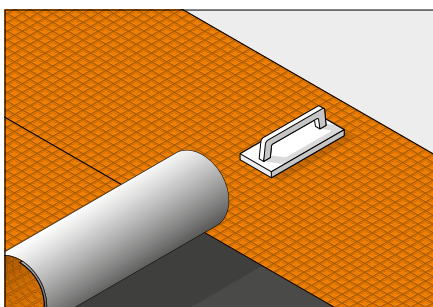

Example: Schlüter®-DITRA

DITRA uncoupling mats available in the system:

- Schlüter-DITRA/-DITRA-PS
- Schlüter-DITRA-DRAIN
- Schlüter-DITRA-HEAT/-DITRA-HEAT-PS

The uncoupling mat can be installed in accordance with the manufacturer's recommendations in the respective product data sheet as soon as the cement screed is ready to bear weight.

On gypsum-based screeds, the uncoupling mats can only be installed when the screed has reached a residual moisture level of <2 CM %.

Floor covering materials, such as parquet, vinyl or carpet, may be directly installed over the Schlüter-BEKOTEC screed **without** the use of uncoupling mats as soon as the required residual moisture has been reached (see also *Residual Moisture* on page 150).

Depending on the thickness of non-ceramic coverings, it may be necessary to level the screed in order to avoid height discrepancies between the different coverings. The screed coverage may be increased to max. 25 mm for levelling (see *table* on page 25). In addition to the applicable installation guidelines, note the permissible residual moisture content of the screed for the selected covering material.

For further information about the surface covering, see page 148.

## Installing joints in the surface covering with the Schlüter®-DILEX product series



Example: Schlüter®-DILEX-F

Coverings of ceramic tile, natural or agglomerate stone can be directly installed on top of Schlüter-DITRA uncoupling mats, using the thin bed method. The necessary joints in the ceramic covering can simply follow the joints of the tile pattern.

Divide the covering above the uncoupling mats, in accordance with the applicable regulations, into fields using movement joints.

If the BEKOTEC screed includes movement joints, they must be continued in the same location in the covering. The design of movement joints should start at corners, e.g. at pillars and chimneys. If installing non ceramic surfaces, the applicable installation guidelines and manufacturer recommendations must be observed.

We recommend the movement joint profiles of the Schlüter-DILEX series for creating movement joints.

*For more details about creating edge joints and connection joints, see page 30 + 31.*

## Additional products for wetrooms and bathrooms



The surfaces of areas such as public showers, swimming pool surrounds and barrier free bathrooms must be constructed as bonded waterproofing assemblies. The following products of Schlüter-Systems may be used as supplements:

- Schlüter-DITRA waterproofing and uncoupling mat (*product data sheet 6.1*)
- Schlüter-DITRA-HEAT waterproofing and uncoupling mat (*product data sheet 6.4*)
- Schlüter-KERDI for waterproofing wall and floor areas (*product data sheet 8.1*)

These waterproofing membranes can be installed in accordance with the waterproofing standard 18534. Water exposure classes: W0-I to W3-I. They also feature the national technical approval (abP) required in Germany.

Moisture load class according to ZDB: 0 to B0, as well as A and C.



Schlüter-DITRA is a polypropylene mat with EasyCut gridlines as well as square, dovetailed EasyFill recesses and an anchoring fleece laminated to the underside. DITRA provides waterproofing, vapour pressure equalisation layer for back side moisture and uncoupling.

Joints and wall transitions are sealed with Schlüter-KERDI-KEBA, using the sealing adhesive Schlüter-KERDI-COLL-L.

Schlüter-DITRA-HEAT is a polypropylene membrane with a cut back stud structure and an anchoring fleece laminated on the underside. It is a universal substrate for tile coverings, which serves as an uncoupling layer, bonded waterproofing and vapour pressure equalisation and is designed for the attachment of the matching heating cables of the floor and wall heating system. Joints and wall transitions are sealed with Schlüter-KERDI-KEBA, using the sealing adhesive Schlüter-KERDI-COLL-L.

Schlüter-KERDI is a crack-bridging waterproofing membrane of soft polyethylene with a special fleece fabric laminated on both sides for effective anchoring in the tile adhesive. It is suitable for waterproofing in conjunction with tiled surfaces.

KERDI was developed for bonded waterproofing assemblies with coverings of tiles and pavers. The waterproofing membrane is adhered to a level substrate with a suitable tile adhesive. Tiles are then installed directly on KERDI, using the thin-bed method.



# Product service and planning materials

Our service

- **Technical consulting**
- **Calculation of material needs**
- **Calculation service**
- **Tender documents**
- **PLANCAL data record**
- **Download data record VDI**

## Technical consulting

Our Technical Department will be pleased to assist with any questions you may have concerning the assembly and the corresponding heating and control technology. The department develops individual construction designs and solutions for your building projects.

## Heating capacity calculation

Our software solutions allow us to determine the heating requirements of buildings on the basis of the corresponding drawings and data in order to guarantee the most efficient heat distribution or cooling function of the BEKOTEC-THERM ceramic thermal comfort floor.

We recommend using the project engineering data sheets and Appendices from page 160 ff. for this.

## Heating system design

We can use existing drawings, information about the number and size of rooms as well as the required heating load to calculate the design of the heating system. This includes the determination of the required heating circuits and the installation spacing. We will draw up a material list that includes all necessary components. Such lists can be supplied as tables or as installation diagrams with heating circuits.



Our project engineering data sheets (see Appendix) are used as the basis for designing the BEKOTEC-THERM system (*from page 160 ff.*).

visit our website at

**bekotec-therm.co.uk**



For a non-binding material and component enquiry, scan the QR CODE.



## Tender documents

Our own tender texts can be found online at **bekotec-therm.co.uk** for downloading. We can develop customised materials for tenders based on the technical design of Schlüter-BEKOTEC-THERM systems.

## On site consulting

Our qualified consultants of the field service will be pleased to arrange a site visit for further details.

**Note:** Our service is non-binding and must be coordinated and, if necessary, adapted by the expert planner on the basis of the structural conditions. Following prior agreement, we reserve the right to charge extra for design development that exceeds the framework of conventional product advisement.





# Schlüter®-BEKOTEC-EN 23 FI 30

The quiet type with insulation



**BEKOTEC-EN 23 FI 30** - suitable for conventional, semi-dry screeds and flowing screeds on cement or gypsum screeds.

## Schlüter-BEKOTEC-EN 23 FI 30 at a glance

### General product properties

Material studded sheet	Polystyrene (PS) with 70% recycled content
Material heat and sound insulation	Expanded polystyrene DES sg (EPS 30 mm)
Panel height	53 mm
Width	1275 mm
Length	975 mm
Weight	1650 g
Working area	1.08 m <sup>2</sup> (1.2 x 0.9 m)

### System data

Weight per unit area with 8 mm coverage	58 kg/m <sup>2</sup>
Screed volume with 8 mm coverage	28.5 l/m <sup>2</sup>
Traffic load	up to 5 kN/m <sup>2</sup>
System heating pipes	diameter 14 mm silver grey diameter 16 mm orange
Heating pipe installation spacing	75/150/225/300 mm

### Technical properties

Density (structured polystyrene)	1.05 g/cm <sup>3</sup>
Density (expanded polystyrene)	23 kg/m <sup>3</sup>
Resistance to temperature	-30 °C to +70 °C
Impact sound improvement measure according to DIN EN ISO 10140-1	Up to 28 dB
Thermal conductivity	0.039 W/mK
Thermal resistance (R-value)	0.769 m <sup>2</sup> K/W
U value	1.30 W/m <sup>2</sup> K
Fire resistance class acc. to EN 13501-1	E
Dynamic rigidity	20 MN/m <sup>3</sup>
Flexural bending capacity	≥ 100 kPa
Compressibility	CP 2 < 2 mm

### Certifications/approvals

VOC (French regulation / EMICODE)	available (A+/EC 1 PLUS)
CE (EN 13163:2012+A1:2015)	available

# Screed coverage and maximum traffic loads for various surface coverings

## Ceramic coverings

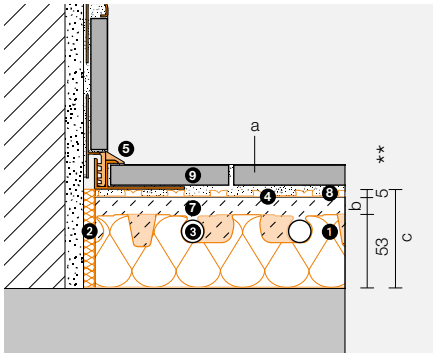

(a) Floor covering	Max. traffic load $q_k$ according to DIN EN 1991	Max. individual load $Q_k$ according to DIN EN 1991	(b) System coverage with conventional screeds	(c) Total thickness of BEKOTEC assembly
Ceramic tile/natural stone	5.0 kN/m <sup>2</sup>	3.5 – 7.0 kN	8 – 25 mm	66 – 83 mm

\*\* Assembly height DITRA = 5 mm, see 4 for additional product specific assembly heights

## Non-ceramic coverings

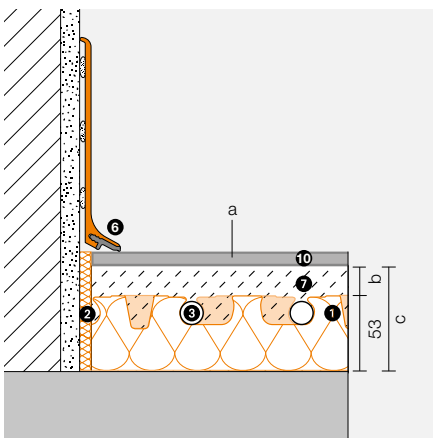

Loose or bonded soft coverings: PVC, vinyl, linoleum, carpet, cork	2 kN/m <sup>2</sup>	2.0 – 3.0 kN	15 – 25 mm	68 – 78 mm
Adhered parquet without tongue and groove connection	5.0 kN/m <sup>2</sup>	3.5 – 7.0 kN	15 – 25 mm	68 – 78 mm
Adhered parquet with tongue and groove connection	5.0 kN/m <sup>2</sup>	3.5 – 7.0 kN	8 – 25 mm	61 – 78 mm
Floating parquet, laminate and coverings and coverings with click system	2 kN/m <sup>2</sup>	2.0 – 3.0 kN	8 – 25 mm	61 – 78 mm

## System components

- 1 Schlüter®-BEKOTEC-EN 23 FI 30  
Studded screed panel
- 2 Schlüter®-BEKOTEC-BRS 808 KSF  
Edging strip
- 3 Schlüter®-BEKOTEC-THERM-HR  
Heating pipe Ø 14 or 16 mm
- 4 Schlüter®-DITRA uncoupling mat  
Schlüter®-DITRA / -DITRA-PS  
(assembly height from 4 mm)  
or  
Schlüter®-DITRA-DRAIN 4  
(assembly height 6 mm)  
or  
Schlüter®-DITRA-HEAT/  
-DITRA-HEAT-PS  
(assembly height from 6 mm)
- 5 Schlüter®-DILEX -EK or -RF  
Maintenance free edge and movement joint profiles
- 6 Schlüter®-DESIGNBASE-SL, -QD  
Decorative finishing profiles for walls, skirting and floors
- 7 Screed  
based on conventionally applied cement or gypsum screeds  
(see specification on page 32)
- 8 Thin bed tile adhesive
- 9 Ceramic tiles or natural stone
- 10 non-ceramic coverings  
Other coverings (see table) are also feasible in compliance with the applicable installation standards.

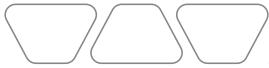

# General information on substrates/raw ceilings, preparatory work and insulation layers

## Substrate:

- Load-bearing
- Clean
- Level
- Correct uneven sections in the floor with screeds or suitable bound fill in advance.

**Bound fills:** Bound fills are permitted

**Heat insulation:** Additional layers of insulation are permitted.

**Sound insulation:** Not permitted

**If using flowing screeds, installation of a PE separating layer on recommended insulation materials.**

## Edging strips for BEKOTEC-EN 23 FI 30

	<b>BRS 810</b> for traditional semi-dry screeds only Height: 100 mm, thickness: 8 mm	<b>BRSK 810</b> for traditional semi-dry screeds only Height: 100 mm, thickness: 8 mm	<b>BRS 808 KF</b> for traditional semi-dry screeds and flowing screeds Height: 80 mm, thickness: 8 mm	<b>BRS 808 KSF</b> for traditional semi-dry screeds and flowing screeds Height: 80 mm, thickness: 8 mm
<b>EN 23 FI 30</b>	<b>X</b>	<b>X</b>	<b>X</b>	<b>X</b>

## Installation of the studded screed panel

The installation direction is indicated by the tapered connection studs, which are shown in green colour in the drawing. Cut segments that are longer than > 30 cm can fit into the next row. Remaining areas or cut outs at doors and protrusions and near distributor boxes can be covered with the levelling panel Schlüter-BEKOTEC-ENFGI. The protruding studded foil must be removed in the edge area of the first row.

**Important:** With flowing screeds, the panel abutting joints must be tightly sealed, e.g. with adhesive tape!

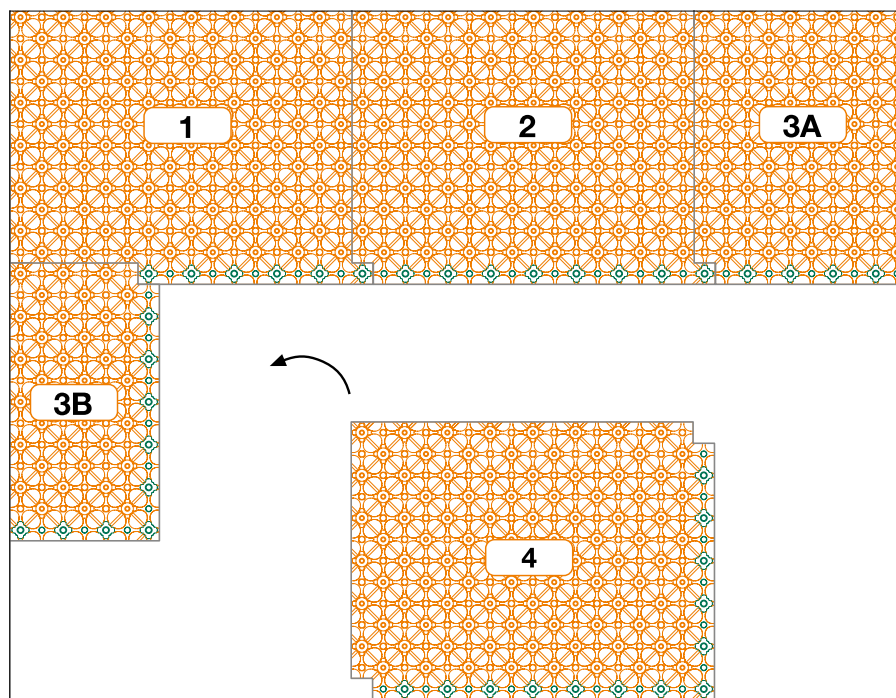

Installation process (with optimal use of material)

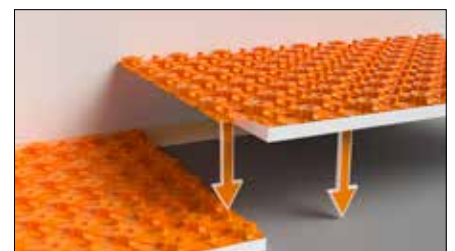

Laying out and fitting the studded screed panel  
Schlüter-BEKOTEC-EN 23 FI 30

## Heating pipe installation

The system heating pipes ( $\varnothing$  14 mm or 16 mm) are installed at double the installation spacing to the reversal loop. After the reversal loop, insert the return line (blue) into the centre of the remaining space.

**Important:** Form the heating pipes as shown in the drawing

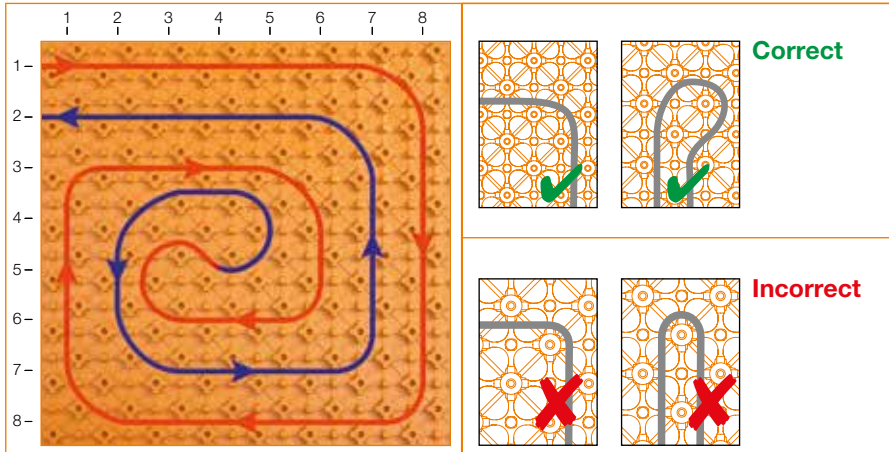

The spacing of the pipes must be determined on the basis of the required heating output and cooling output (see pages 40 - 49).

**Important:** Before and during the installation of the screed, the studded panel may need to be protected from mechanical damage with suitable measures, such as laying out wooden boards.

## Levelling panel

The levelling panel Schlüter-BEKOTEC-ENFGI is installed in the area of the heating circuit distributors and at thresholds to simplify connections and to minimise cutting waste.

It consists of smooth polystyrene foil material as well as a 30 mm thick polystyrene base carrier and is installed next to the studded panel.

### Technical data

<b>Dimensions:</b>	1200 x 900 = 1.08 m <sup>2</sup>
<b>Thickness:</b>	30.1 mm
<b>Heat conductor class:</b>	0.039 W/mK
<b>U value:</b>	1,30 W/m <sup>2</sup> K
<b>Thermal resistance:</b>	≥ 0.769 m <sup>2</sup> K/W



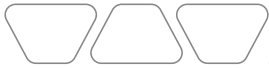

# Performance diagrams

Ceramic thermal comfort floor, heating pipes  $\varnothing = 16 \text{ mm}$

Floor covering: ceramic tile, natural stone, cast stone incl. Schlüter-DITRA mat.

Surface cover resistance  $R_{\lambda} = 0.00 \text{ m}^2 \text{ K/W}$

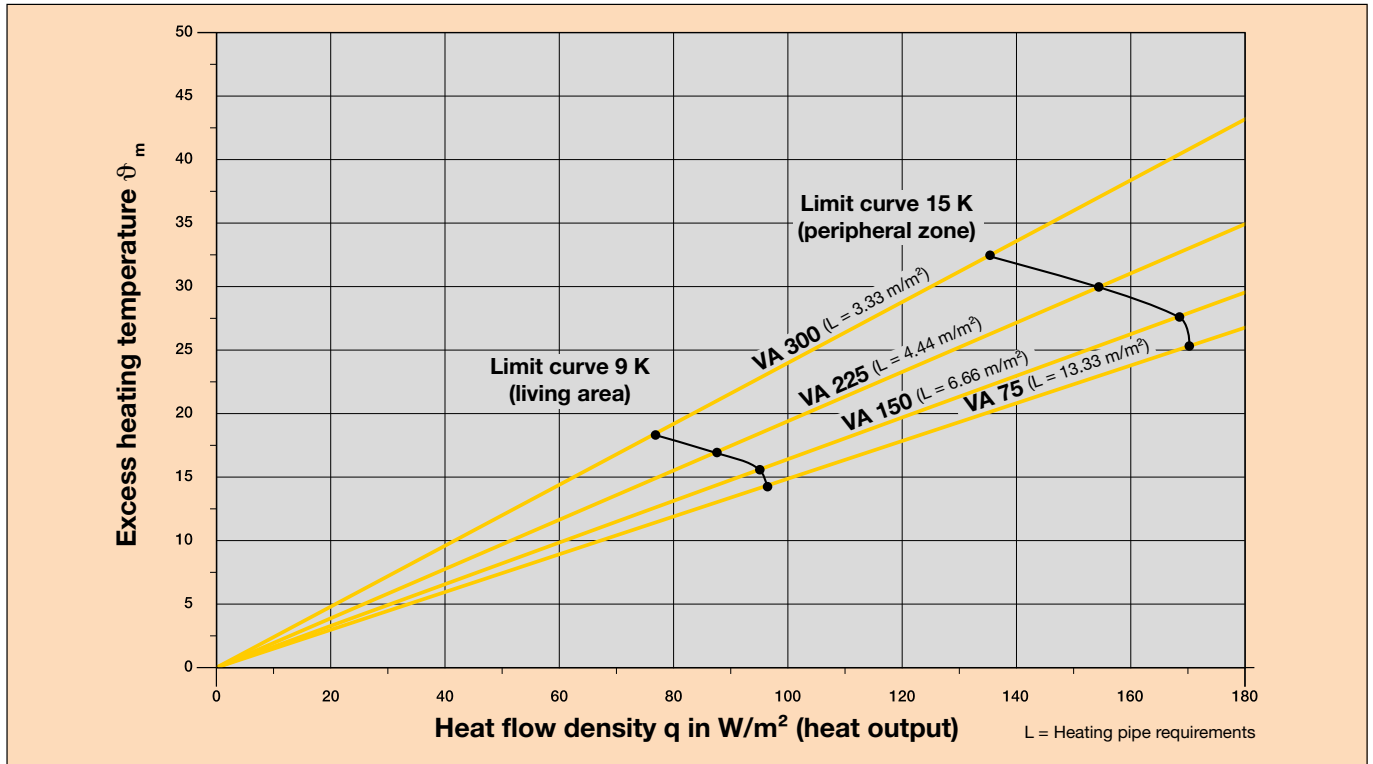

Performance test according to DIN EN 1264

Room temp. °C	Supply temp. °C		Living area													Peripheral zone												
			25	30	35	40	45	50	55	60	65	70	75	80	85	90	95	100	105	110	115	120	125	130	135	140	145	
		Heat flow density W/m <sup>2</sup> (spec. heat output W/m <sup>2</sup> )	25	30	35	40	45	50	55	60	65	70	75	80	85	90	95	100	105	110	115	120	125	130	135	140	145	
		Avg. surface temp. °C	22.7	23.6	24.5	25.5	26.4	27.3	28.2									29.1	30.0	30.9	31.8	32.7						
20	30	Installation spacing VA mm	225	225	150	150	150	150	75	75	75																	
		Max. heating circuit area m <sup>2</sup>	25	22	18	16	14	10	8	7	5																	
		Max. heating circuit length m	119	105	127	114	101	74	114	101	74																	
20	35	Installation spacing VA mm	300	300	225	225	225	225	150	150	150	150	150	75	75	75	75	75	75									
		Max. heating circuit area m <sup>2</sup>	30	28	25	22	20	18	17	15	14	13	10	9	8	7.5	7	5	4									
		Max. heating circuit length m	107	101	119	105	96	87	121	107	101	94	74	127	114	107	101	74	61									
20	40	Installation spacing VA mm	300	300	300	300	225	225	225	150	150	150	150	150	150	150	150	150	75	75	75	75	75	75	75	75	75	
		Max. heating circuit area m <sup>2</sup>	34	33	30	28	26	24	21	19	17	16	15	14	13	12	11	10	9	8	7	6	5	4.5	4	3		
		Max. heating circuit length m	121	117	107	101	123	114	101	92	121	114	107	101	94	87	81	74	127	114	101	87	74	67	61	47		
20	43	Installation spacing VA mm	300	300	300	300	300	225	225	225	150	150	150	150	150	150	150	150	150	150	75	75	75	75	75	75	75	
		Max. heating circuit area m <sup>2</sup>	36	35	34	33	30	28	26	24	22	18	17	16	15	14	13	12	11	10	9	8	7	6	5	4.5	4	3
		Max. heating circuit length m	127	124	121	117	107	101	123	114	105	127	121	114	107	101	94	87	81	74	127	114	107	101	94	87	81	
		Avg. surface temp. °C	26.7	27.6	28.5	29.5	30.4	31.3	32.2									33.1	34.0	34.9								
24	30	Installation spacing VA mm	150	75	75																							
		Max. heating circuit area m <sup>2</sup>	12	7	6																							
		Max. heating circuit length m	87	101	87																							
24	35	Installation spacing VA mm		150	150	150	150	150	75	75	75	75																
		Max. heating circuit area m <sup>2</sup>		18	16	14	12	9	8	7	6	4.5																
		Max. heating circuit length m		127	114	101	87	67	114	101	87	67																
24	40	Installation spacing VA mm			150	150	150	150	150	150	150	75	75	75	75	75	75	75	75									
		Max. heating circuit area m <sup>2</sup>			18	17	16	15	14	13	12	9	8	7	6.5	6	5.5	5	4.5									
		Max. heating circuit length m			127	121	114	107	101	94	87	127	114	101	94	87	81	74	67									
24	43	Installation spacing VA mm					150	150	150	150	150	150	150	150	75	75	75	75	75	75	75	75						
		Max. heating circuit area m <sup>2</sup>					18	17	16	15	14	13	12	11	9	8	7.5	7	6.5	6	5.5	5						
		Max. heating circuit length m					127	121	114	107	101	94	87	81	127	114	107	101	94	87	81	74						

Limit curve living area/peripheral zone

Data does not replace precise planning according to DIN EN 1264.

**Presumed marginal conditions:**

Pressure loss: max. 250 mbar  
 Sub insulation R/(U): 0.75 m<sup>2</sup>K/W / (1.33 W/m<sup>2</sup>K)

tu: 15 °C  
 Single connection length: 3 - 4 m

# Performance diagrams

Vinyl, linoleum or parquet up to approx. 8 mm\*, heating pipes Ø = 16 mm

Surface cover resistance  $R_{\lambda} = 0.05 \text{ m}^2 \text{ K/W}$

Follow manufacturer's specifications

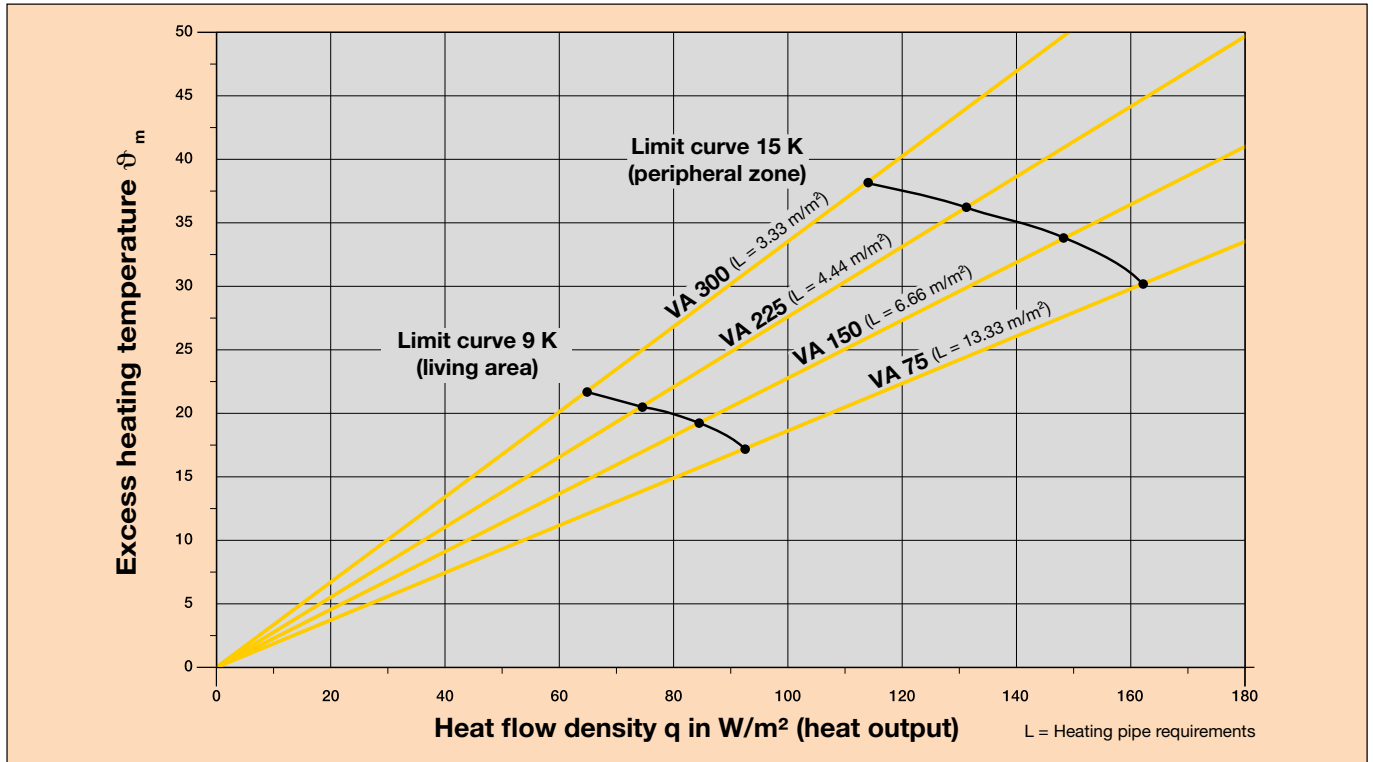

Performance test according to DIN EN 1264

Room temp. °C	Supply temp. °C	Living area															Peripheral zone												
		Heat flow density $W/m^2$ (spec. heat output $W/m^2$ )																											
		25	30	35	40	45	50	55	60	65	70	75	80	85	90	95	100	105	110	115	120	125	130	135	140	145			
		Avg. surface temp. °C																											
		22.7	23.6	24.5	25.5	26.4	27.3	28.2	29.1	30.0	30.9	31.8	32.7	33.1	34.0	34.9													
20	30	Installation spacing VA mm	150	150	150	75	75																						
		Max. heating circuit area $m^2$	16	15	13	8	7																						
		Max. heating circuit length m	114	107	94	114	101																						
20	35	Installation spacing VA mm	300	300	225	225	150	150	75	75	75																		
		Max. heating circuit area $m^2$	33	30	26	22	18	16	11	8	7	5																	
		Max. heating circuit length m	117	107	123	105	127	114	81	114	101	74																	
20	40	Installation spacing VA mm	300	300	300	300	225	225	150	150	150	150	75	75	75	75	75												
		Max. heating circuit area $m^2$	35	33	28	25	23	21	18	17	15	13	10	8	7	6	5	4											
		Max. heating circuit length m	124	117	101	91	110	101	127	121	107	94	74	114	101	87	74	61											
20	43	Installation spacing VA mm	300	300	300	300	300	225	225	225	150	150	150	15	150	75	75	75	75	75	75								
		Max. heating circuit area $m^2$	35	35	33	30	28	26	24	21	18	16	14	12	10	9	8	7	6	5	3.5								
		Max. heating circuit length m	124	124	117	107	101	123	114	105	127	114	101	87	74	127	114	101	87	74	54								
		Avg. surface temp. °C																											
		26.7	27.6	28.5	29.5	30.4	31.3	32.2	33.1	34.0	34.9																		
24	30	Installation spacing VA mm	75																										
		Max. heating circuit area $m^2$	7																										
		Max. heating circuit length m	101																										
24	35	Installation spacing VA mm		150	150	150	75	75																					
		Max. heating circuit area $m^2$		13	12	10	8	6.5																					
		Max. heating circuit length m		114	87	74	114	94																					
24	40	Installation spacing VA mm				150	150	150	150	75	75	75																	
		Max. heating circuit area $m^2$				16	14	12	9	8	7	5																	
		Max. heating circuit length m				114	101	87	67	114	101	74																	
24	43	Installation spacing VA mm						150	150	150	75	75	75	75	75														
		Max. heating circuit area $m^2$						16	14	12	9	8	7	6	5														
		Max. heating circuit length m						114	101	87	127	114	101	87	74														

Limit curve living area/peripheral zone

Data does not replace precise planning according to DIN EN 1264.

**Presumed marginal conditions:**

Pressure loss: max. 250 mbar  
 Sub insulation R/(U): 0.75  $m^2K/W$  / (1.33  $W/m^2K$ )

tu: 15 °C  
 Single connection length: 3 - 4 m







## Cooling output of BEKOTEC-EN 23 FI 30

### Notes:

- Average cooling output of 30 - 40 W/m<sup>2</sup> possible with ceramic coverings
- This lets the room temperature be lowered by approx. 3 °C
- Best cooling and heating values with ceramic coverings
- Normal cooling water temperature with approx. 18 °C.
- Ideal for use with heat pumps

The following performance data were determined in W/m<sup>2</sup> based on the installation spacing VA and the temperature difference  $\Delta T$  (room temperature cooling water temperature) according to DIN EN 1264.

Heating pipe  $\varnothing = 16$  mm

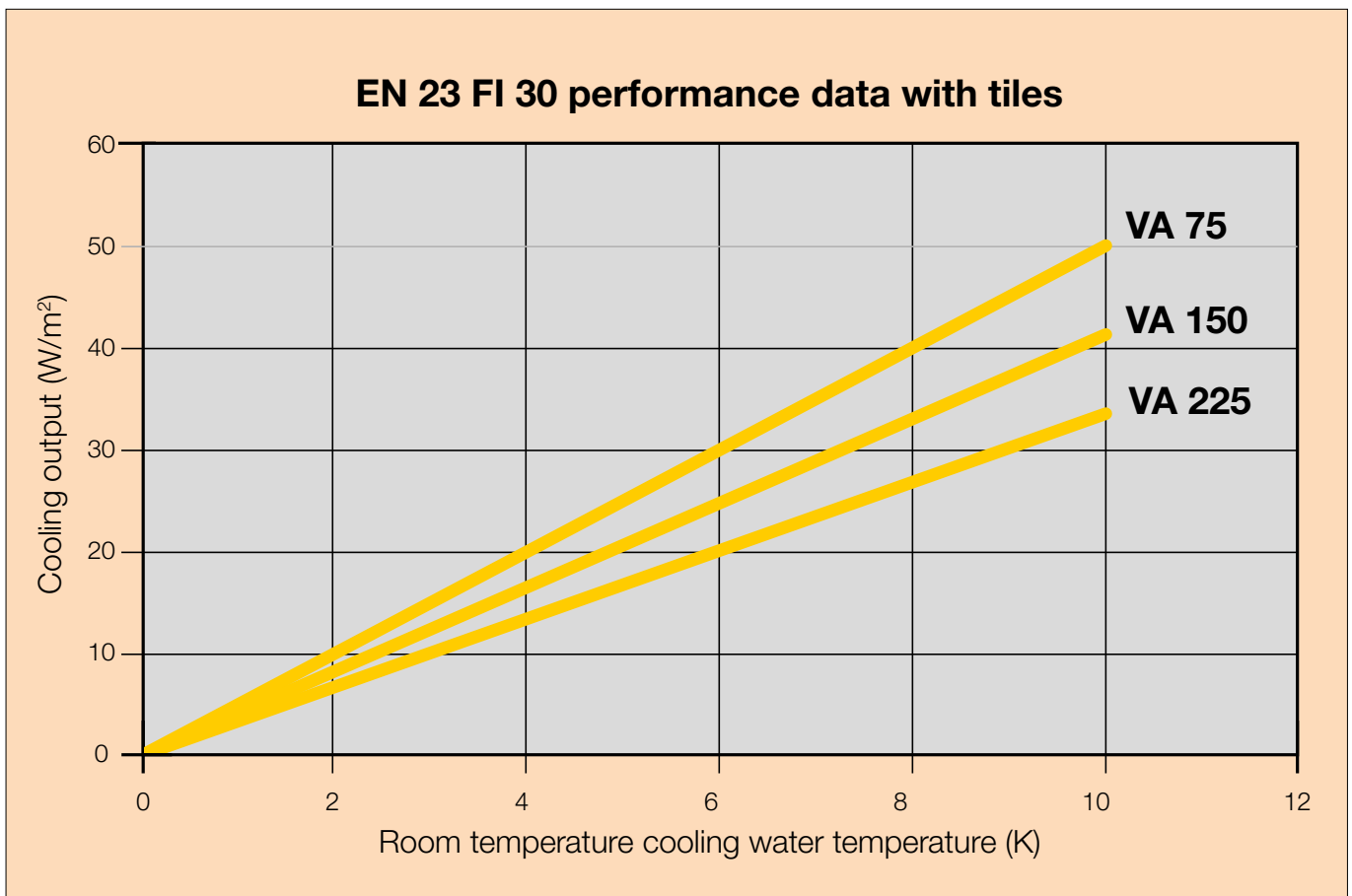

Performance test according to DIN EN 1264

# Performance diagrams

Ceramic thermal comfort floor, heating pipes  $\varnothing = 14$  mm

Floor covering: ceramic tile, natural stone, cast stone incl. Schlüter-DITRA mat.

Surface cover resistance  $R_{\lambda} = 0.00$  m<sup>2</sup> K/W

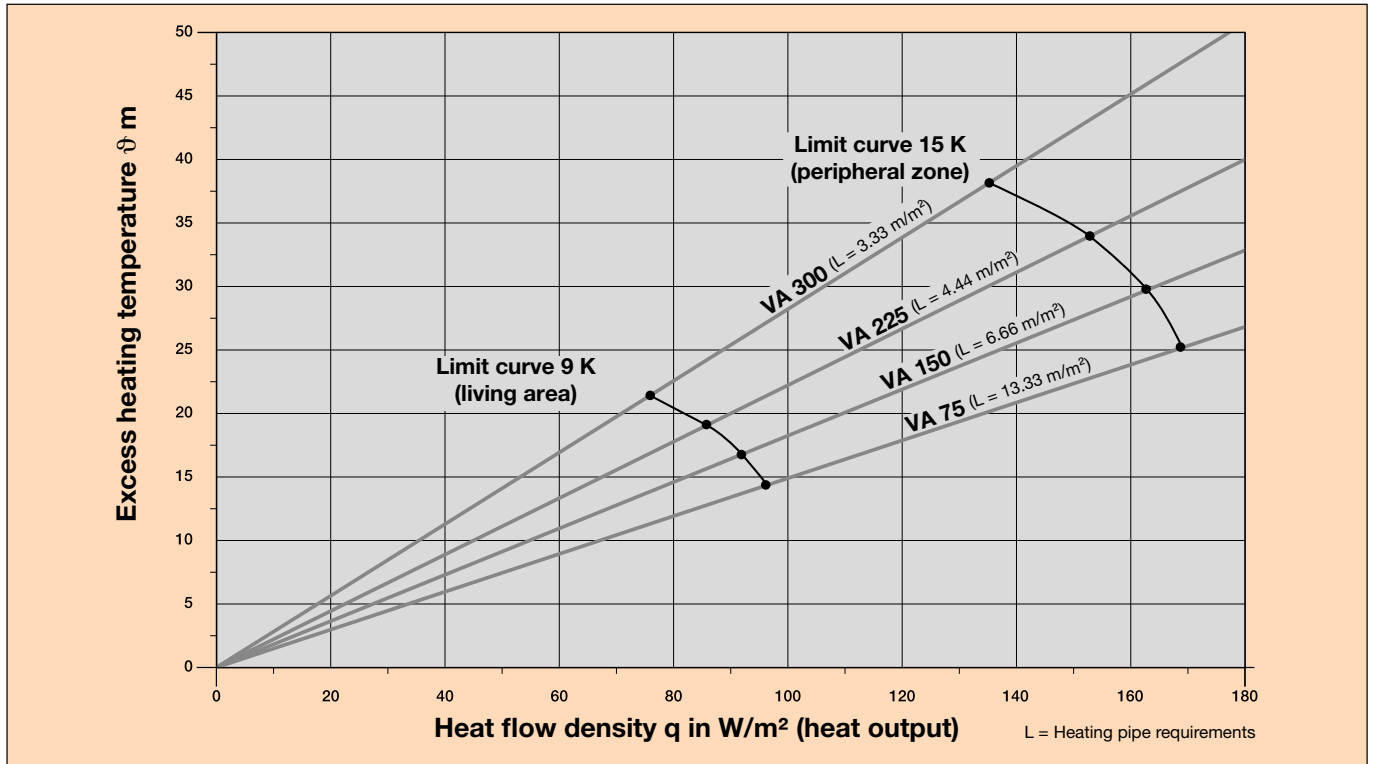

Performance data according to DIN EN 1264

Room temp. °C	Supply temp. °C	Living area														Peripheral zone													
		25	30	35	40	45	50	55	60	65	70	75	80	85	90	95	100	105	110	115	120	125	130	135	140	145			
		Heat flow density W/m <sup>2</sup> (spec. heat output W/m <sup>2</sup> )																											
		Avg. surface temp. °C																											
20	30	Installation spacing VA mm	225	225	150	150	150	75	75	75																			
		Max. heating circuit area m <sup>2</sup>	19	16	14	12	9	7	5	4																			
		Max. heating circuit length m	92	78	101	87	67	101	74	61																			
20	35	Installation spacing VA mm	225	225	225	225	225	150	150	150	150	75	75	75	75	75	75												
		Max. heating circuit area m <sup>2</sup>	24	22	20	18	16	15	14	12	10	7.5	7	6	5.5	5	4	3.5											
		Max. heating circuit length m	114	105	96	87	79	107	101	87	74	57	101	87	81	74	61	54											
20	40	Installation spacing VA mm	300	300	300	300	225	225	150	150	150	150	150	150	150	150	75	75	75	75	75	75	75	75	75	75	75	75	75
		Max. heating circuit area m <sup>2</sup>	30	27	25	23	20	18	16	15	14	13	12	11	9	8	8	7	6.5	6	5.5	5	4.5	3.5					
		Max. heating circuit length m	107	97	91	84	96	87	114	107	101	94	87	81	67	61	114	101	94	87	81	74	67	54					
20	43	Installation spacing VA mm	300	300	300	300	300	225	225	225	225	150	150	150	150	150	150	150	150	75	75	75	75	75	75	75	75	75	
		Max. heating circuit area m <sup>2</sup>	33	30	28	26	24	24	22	20	18	16	14	13	12	11	10	9	8	8	7	6.5	6	5	4.5	4	3.5		
		Max. heating circuit length m	117	107	101	94	87	114	105	96	87	114	101	94	87	81	74	67	61	114	101	94	87	74	67	61	54		
		Avg. surface temp. °C																											
24	30	Installation spacing VA mm	75	75	75																								
		Max. heating circuit area m <sup>2</sup>	5.5	5	4																								
		Max. heating circuit length m	81	74	61																								
24	35	Installation spacing VA mm			150	150	150	150	75	75	75	75	75																
		Max. heating circuit area m <sup>2</sup>			14	12	10	8	7	6	5.5	4	2.5																
		Max. heating circuit length m			101	87	74	61	101	87	81	61	41																
24	40	Installation spacing VA mm				150	150	150	150	150	150	150	75	75	75	75	75	75	75	75	75	75	75	75	75	75	75	75	
		Max. heating circuit area m <sup>2</sup>				16	15	14	12	11	10	9	7	6.5	6	5.5	5	4	3	2.5									
		Max. heating circuit length m				114	107	101	87	81	74	67	101	94	87	81	74	61	47	41									
24	43	Installation spacing VA mm						150	150	150	150	150	150	150	150	75	75	75	75	75	75	75	75	75	75	75	75	75	
		Max. heating circuit area m <sup>2</sup>							16	15	14	13.5	12	11	10	9	8	7.5	7	6.5	6	5	4						
		Max. heating circuit length m							114	107	101	97	87	81	74	67	114	107	101	94	87	74	61						

Limit curve living area/peripheral zone

Data does not replace precise planning according to DIN EN 1264.

**Presumed marginal conditions:**

Pressure loss: max. 250 mbar  
 Sub insulation R/(U): 0.75 m<sup>2</sup>K/W / (1.33 W/m<sup>2</sup>K)

tu: 15 °C  
 Single connection length: 3 - 4 m



# Performance diagrams

Vinyl, linoleum or parquet up to approx. 8 mm, heating pipes  $\varnothing = 14$  mm

Floor covering: Vinyl, linoleum or parquet up to approx. 8 mm (observe manufacturer recommendations).

Surface cover resistance  $R_{\lambda} = 0.05$  m<sup>2</sup> K/W

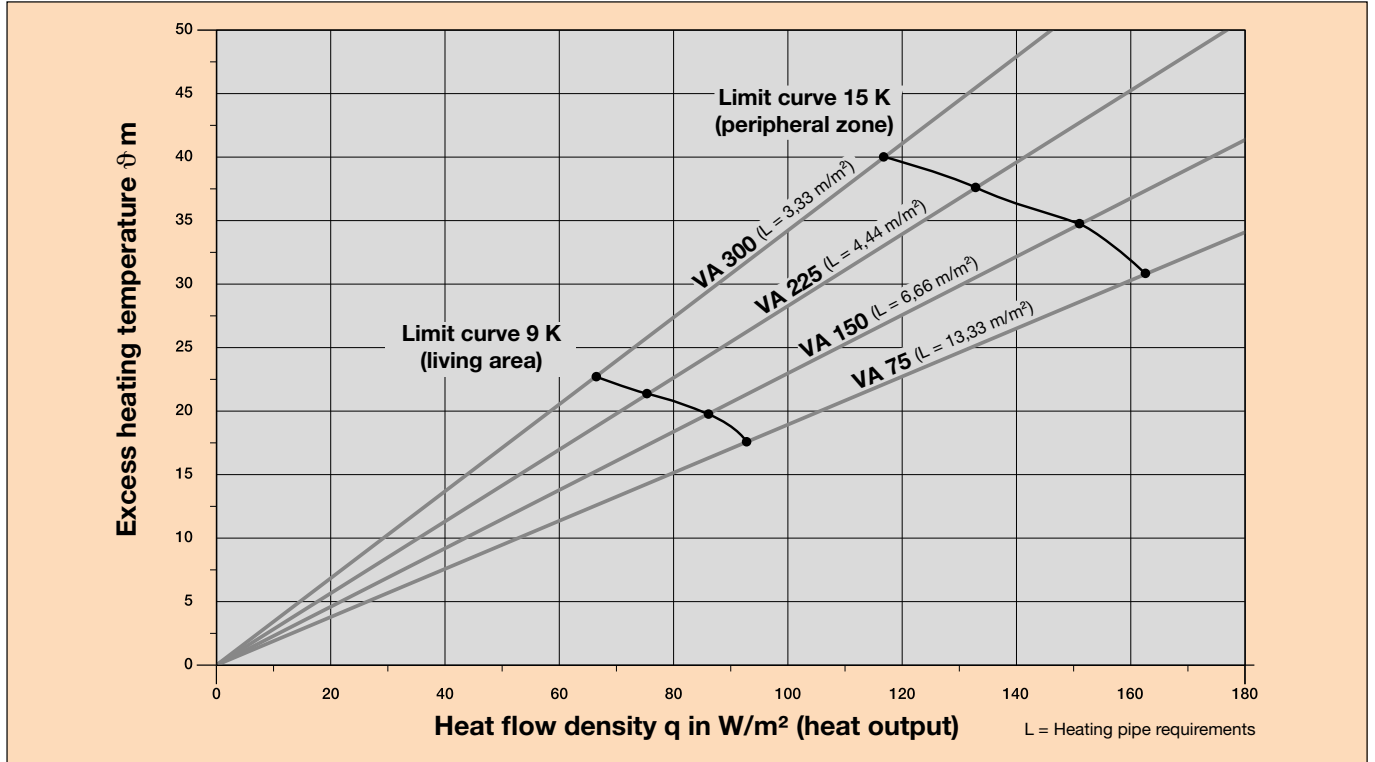

Performance data according to DIN EN 1264

Room temp. °C	Supply temp. °C		Living area													Peripheral zone													
			25	30	35	40	45	50	55	60	65	70	75	80	85	90	95	100	105	110	115	120	125	130	135	140	145		
		Heat flow density W/m <sup>2</sup> (spec. heat output W/m <sup>2</sup> )	25	30	35	40	45	50	55	60	65	70	75	80	85	90	95	100	105	110	115	120	125	130	135	140	145		
		Avg. surface temp. °C	22.7	23.6	24.5	25.5	26.4	27.3	28.2									29.1	30.0	30.9	31.8	32.7							
20	30	Installation spacing VA mm	150	150	150	75	75																						
		Max. heating circuit area m <sup>2</sup>	13	12	8	6	4.5																						
		Max. heating circuit length m	94	87	61	87	67																						
20	35	Installation spacing VA mm	300	225	225	225	150	150	75	75	75	75																	
		Max. heating circuit area m <sup>2</sup>	26	24	20	18	14	11	8	7	6	3.5																	
		Max. heating circuit length m	94	114	96	87	101	81	114	101	87	54																	
20	40	Installation spacing VA mm	300	300	300	225	225	225	150	150	150	150	75	75	75	75	75												
		Max. heating circuit area m <sup>2</sup>	28	25	24	22	20	17	15	13	11	8	8	7	6	5	3												
		Max. heating circuit length m	101	91	87	105	96	83	107	94	81	61	114	101	87	74	47												
20	43	Installation spacing VA mm	300	300	300	300	225	225	225	150	150	150	150	150	75	75	75	75	75										
		Max. heating circuit area m <sup>2</sup>	30	28	26	24	22	20	18	16	14	13	11	8.5	7.5	7	6	5	4										
		Max. heating circuit length m	107	101	94	87	105	96	87	114	101	94	81	64	107	101	87	74	61										
		Avg. surface temp. °C	26.7	27.6	28.5	29.5	30.4	31.3	32.2									33.1	34.0	34.9									
24	30	Installation spacing VA mm	75																										
		Max. heating circuit area m <sup>2</sup>	6																										
		Max. heating circuit length m	87																										
24	35	Installation spacing VA mm	150	150	75	75	75	75																					
		Max. heating circuit area m <sup>2</sup>	13	10	8	6	4	3																					
		Max. heating circuit length m	94	74	114	87	61	47																					
24	40	Installation spacing VA mm				150	150	150	75	75	75	75																	
		Max. heating circuit area m <sup>2</sup>				13	11	8	7	6	5	3																	
		Max. heating circuit length m				94	81	61	101	87	74	47																	
24	43	Installation spacing VA mm							150	150	150	75	75	75	75	75													
		Max. heating circuit area m <sup>2</sup>							13	11	9	7.5	6.5	5.5	5	3													
		Max. heating circuit length m							94	81	67	107	94	81	74	47													

Limit curve living area/peripheral zone

Data does not replace precise planning according to DIN EN 1264.

**Presumed marginal conditions:**

Pressure loss: max. 250 mbar  
 Sub insulation R/(U): 0.75 m<sup>2</sup>K/W / (1.33 W/m<sup>2</sup>K)

tu: 15 °C  
 Single connection length: 3 - 4 m





# Cooling output of BEKOTEC-EN 23 FI 30

**Notes:**

- Average cooling output of 30 - 40 W/m<sup>2</sup> possible with ceramic coverings
- This lets the room temperature be lowered by approx. 3 °C
- Best cooling and heating values with ceramic coverings
- Normal cooling water temperature with approx. 18 °C.
- Ideal for use with heat pumps

The following performance data were determined in W/m<sup>2</sup> based on the installation spacing VA and the temperature difference ΔT (room temperature cooling water temperature) according to DIN EN 1264.

## Heating pipe Ø = 14 mm

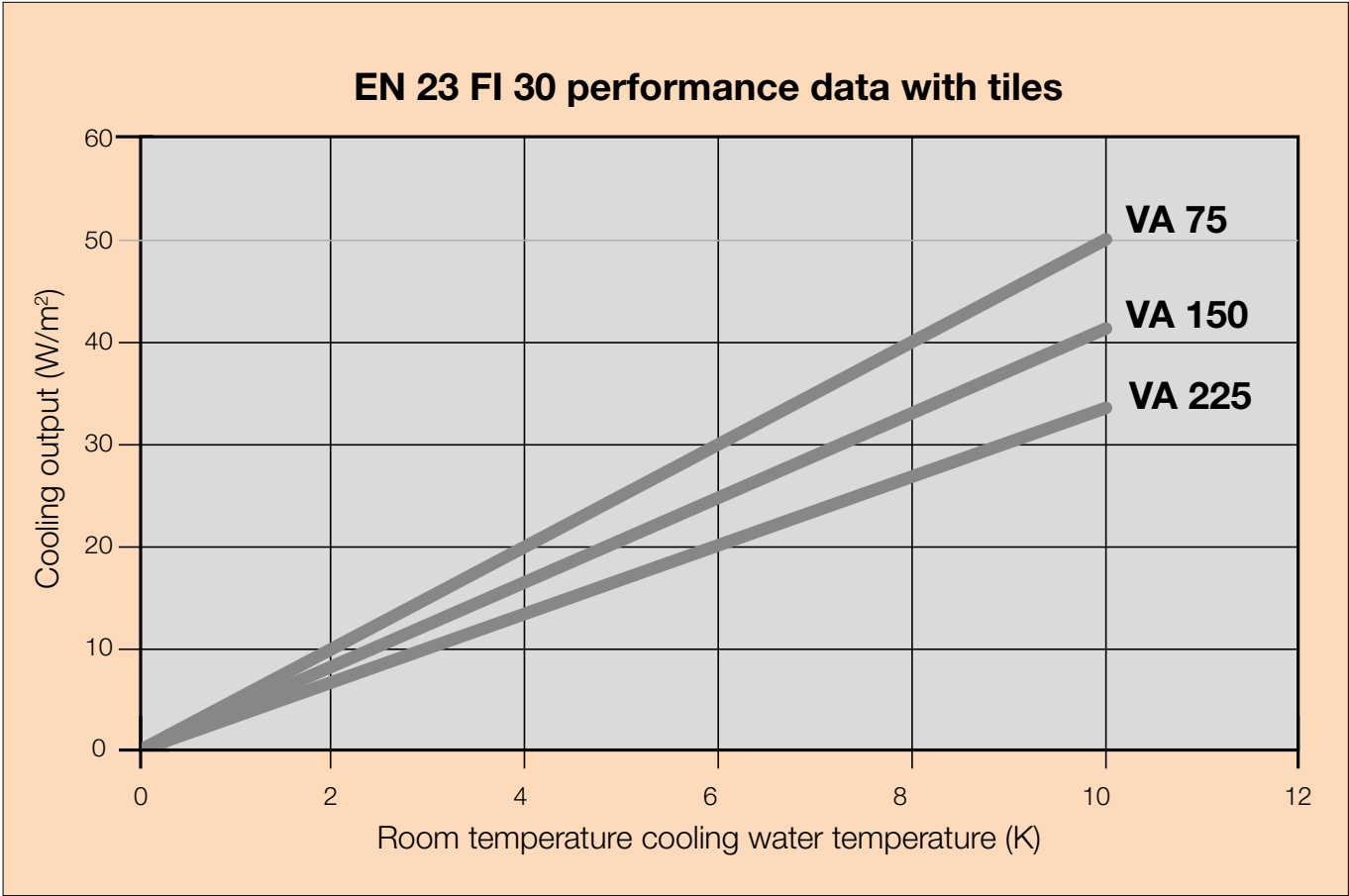

Performance data according to DIN EN 1264



# Schlüter®-BEKOTEC-EN 2520 P / EN 1520 PF

The insulated type

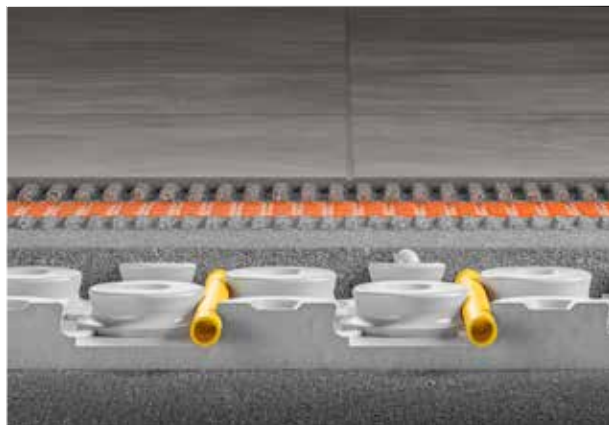

**BEKOTEC-EN 2520 P** - suitable for conventional, semi-dry screeds on cement or gypsum screeds

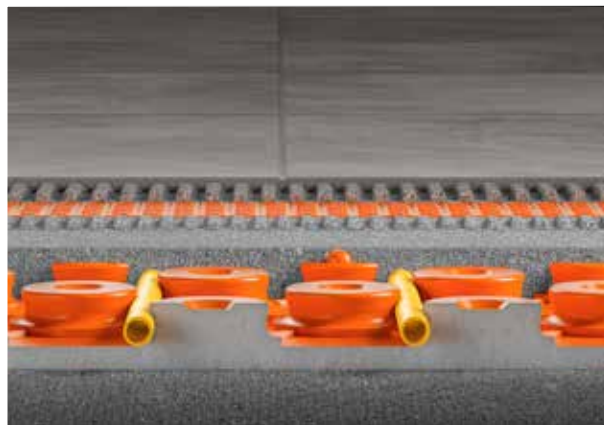

**BEKOTEC-EN 1520 PF** - covered with a protective foil - suitable for conventional, semi-dry screeds and flowing screeds on cement or gypsum screeds and flowing screeds based on cement or calcium sulphate

## Schlüter-BEKOTEC-EN 2520 P / EN 1520 PF at a glance

### General product properties

Heat insulation material	Expanded polystyrene foam (EPS DEO)
Panel height	44 mm (of which 20 mm is the base support plate)
Width	1060 mm
Length	755 mm
Working area	0.8 m <sup>2</sup> (0.755 x 1.06 m)

### System data

Weight per unit area with 8 mm coverage	57 kg/m <sup>2</sup>
Screed volume with 8 mm coverage	28.5 l/m <sup>2</sup>
Traffic load	up to 5 kN/m <sup>2</sup>
System heating pipes	diameter 16 mm orange
Heating pipe installation spacing	75/150/225/300 mm

### Technical properties

Density (structured polystyrene)	-
Density (expanded polystyrene)	EN P 30 kg/m <sup>3</sup> EN PF 25 kg/m <sup>3</sup>
Resistance to temperature	-30 °C to +70 °C
Thermal conductivity	0.033 W/mK
Thermal resistance (R-value)	0.606 m <sup>2</sup> /W
U value	1.650 W/m <sup>2</sup> K
Fire resistance class acc. to EN 13501-1	E

### Certifications/approvals

VOC (French regulation / EMICODE)	available (A+/EC 1 PLUS)
CE (EN 13163:2012+A1:2015)	available
CSTB	available

# Screed coverage and maximum traffic loads for various surface coverings

## Ceramic coverings

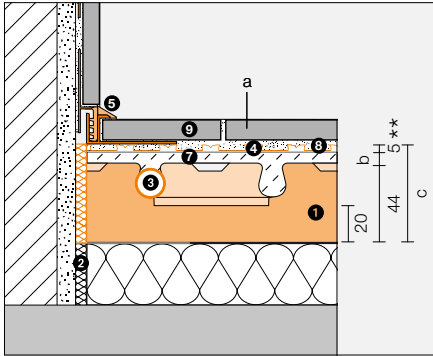

(a) Floor covering	Max. traffic load $q_k$ according to DIN EN 1991	Max. individual load $Q_k$ according to DIN EN 1991	(b) System coverage with conventional screeds	(c) Total thickness of BEKOTEC assembly
Ceramic tile/natural stone	5.0 kN/m <sup>2</sup>	3.5 – 7.0 kN	8 – 25 mm	57 – 74 mm

\*\* Assembly height DITRA = 5 mm, see 4 for additional product specific assembly heights

## Non-ceramic coverings

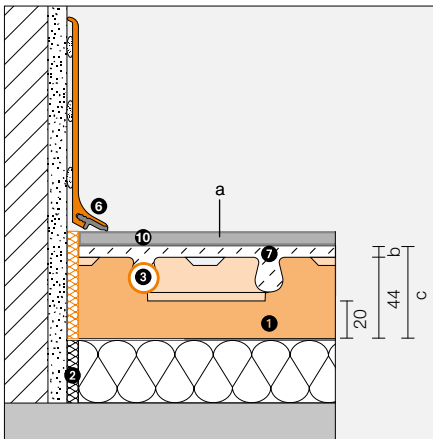

Loose or bonded soft coverings: PVC, vinyl, linoleum, carpet, cork	2 kN/m <sup>2</sup>	2.0 – 3.0 kN	15 – 25 mm	59 – 69 mm
Adhered parquet without tongue and groove connection	5.0 kN/m <sup>2</sup>	3.5 – 7.0 kN	15 – 25 mm	59 – 69 mm
Adhered parquet with tongue and groove connection	5.0 kN/m <sup>2</sup>	3.5 – 7.0 kN	8 – 25 mm	52 – 69 mm
Floating parquet, laminate and coverings with click system	2 kN/m <sup>2</sup>	2.0 – 3.0 kN	8 – 25 mm	52 – 69 mm

## System components

- 1 Schlüter®-BEKOTEC-EN P/ -EN PF  
Studded screed panel
- 2 Schlüter®-BEKOTEC-BRS  
Edging strip
- 3 Schlüter®-BEKOTEC-THERM-HR  
Heating pipe Ø 16 mm
- 4 Schlüter®-DITRA uncoupling mat  
Schlüter®-DITRA / -DITRA-PS  
(assembly height from 4 mm)  
or  
Schlüter®-DITRA-DRAIN 4  
(assembly height 6 mm)  
or  
Schlüter®-DITRA-HEAT/  
-DITRA-HEAT-PS  
(assembly height from 6 mm)
- 5 Schlüter®-DILEX-EK or -RF  
Maintenance free edge and movement joint profiles
- 6 Schlüter®-DESIGNBASE-SL, -QD  
Decorative finishing profiles for walls, skirting and floors
- 7 Screed  
based on conventionally applied cement or gypsum screeds  
(see specification on page 32)
- 8 Thin bed tile adhesive
- 9 Ceramic tiles or natural stone
- 10 Non-ceramic coverings  
Other coverings (see table) are possible in accordance with the respective installation guidelines.



## General information on substrates/raw ceilings, preparatory work and insulation layers

### Substrate:

- Load-bearing
- Clean
- Level
- Correct uneven sections in the floor with screeds or suitable bound fill in advance.

**Bound fills:** Bound fills are permitted

**Heat insulation:** Additional layers of insulation are permitted.

**Sound insulation:** Only one layer of sound insulation is permissible, max. compressibility of CP3 ( $\leq 3$  mm).

**If using flowing screeds, installation of a PE separating layer on insulation materials (only 1520 PF) is recommended.**

### Edging strips for BEKOTEC-EN 2520 P / 1520 PF

	<b>BRS 810</b> for traditional semi-dry screeds only Height: 100 mm, thickness: 8 mm	<b>BRSK 810</b> for traditional semi-dry screeds only Height: 100 mm, thickness: 8 mm	<b>BRS 808 KF</b> for traditional semi-dry screeds and flowing screeds Height: 80 mm, thickness: 8 mm	<b>BRS 808 KSF</b> for traditional semi-dry screeds and flowing screeds Height: 80 mm, thickness: 8 mm
<b>EN 2520 P</b>	<b>X</b>	<b>X</b>	<b>X</b>	<b>X</b>
<b>EN 1520 PF</b>	<b>-</b>	<b>-</b>	<b>X</b>	<b>X</b>

### Installation of the studded screed panel

The Schlüter-BEKOTEC-EN studded panels are precisely cut to size in the edge areas. These panels have an interlocking design. The directional arrows on the topside indicate the alignment of the panels. This ensures a continuous interlocking connection. The panels are installed as a continuous area. Cut out segments that are longer than 30 cm can fit into the next row to reduce waste. The studded BEKOTEC-EN P/EN PF panels can also be fitted at the sides of the floor with their short end. This again cuts down on material waste.

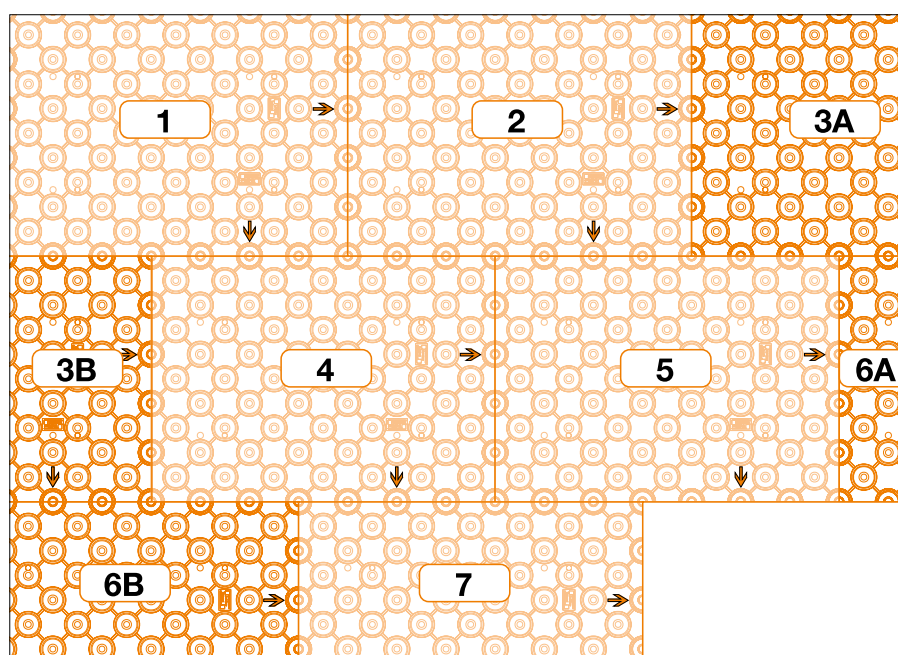

Laying out and fitting the studded screed panel  
Schlüter-BEKOTEC-EN P (-EN PF)

Installation process (with optimal use of material)

## Heating pipe installation

The system heating pipes (Ø 16 mm) are installed at double the installation spacing to the reversal loop. After the reversal point, insert the return line (blue) into the centre of the remaining space.

**Important:** Form the heating pipes as shown in the drawing!

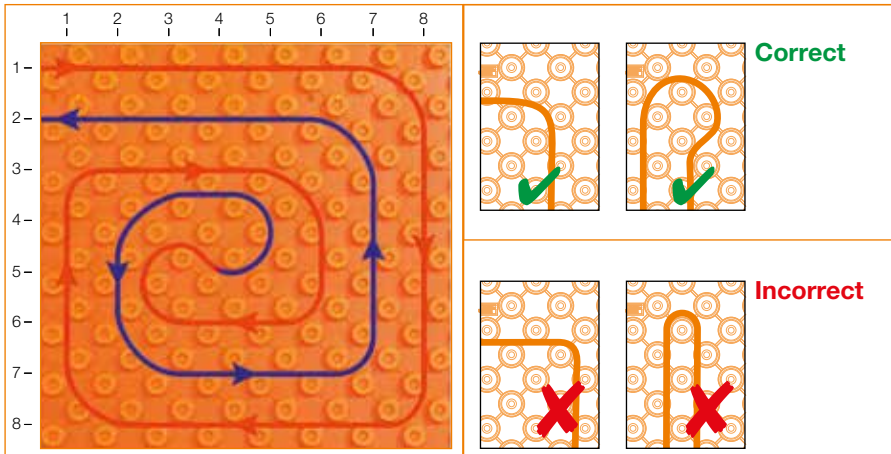

The spacing of the pipes must be determined on the basis of the required heating output and cooling diagrams (see pages 54 - 58).

**Important:** Before and during the installation of the screed, the studded screed panel must be protected from mechanical damage in the traffic areas with suitable measures, such as laying out running boards.

## Levelling panel

Remaining areas or cut outs at doors and protrusions as well as the area with the distribution cabinet can be covered with the levelling panel BEKOTEC-ENR.



### Technical data

<b>Dimensions:</b>	30.5 cm x 45.5 cm = 0.14 m <sup>2</sup>
<b>Thickness:</b>	20 mm
<b>Insulation material:</b>	EPS 040 DEO
<b>Heat conductor class:</b>	040 (0.04 W/mK)
<b>U value:</b>	2.0 W/m <sup>2</sup> K
<b>Thermal resistance:</b>	≥ 0.5 m <sup>2</sup> K/W

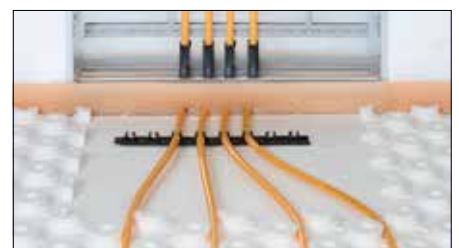



# Performance diagrams

Ceramic thermal comfort floor, heating pipes  $\varnothing = 16 \text{ mm}$

Floor covering: ceramic tile, natural stone, cast stone incl. Schlüter-DITRA mat.

Surface cover resistance  $R_{\lambda} = 0.00 \text{ m}^2 \text{ K/W}$

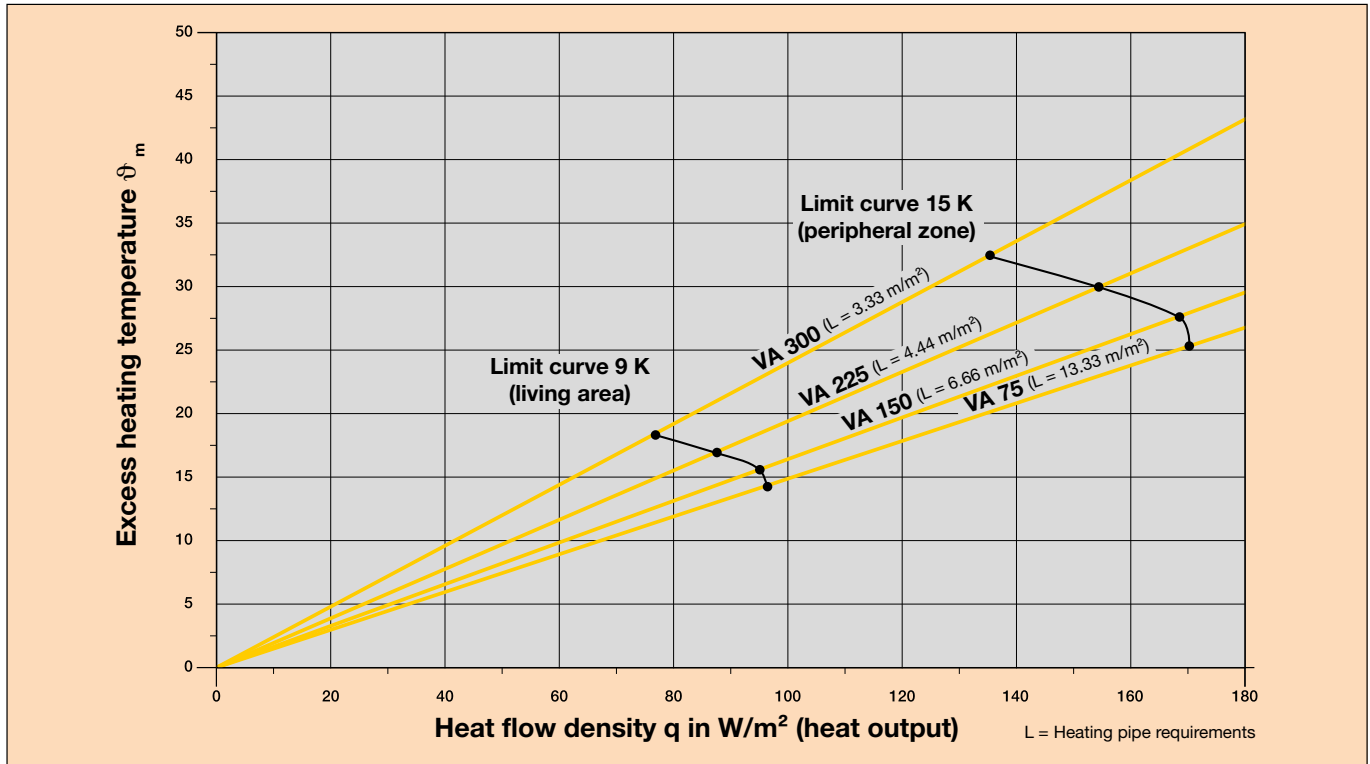

Performance data according to DIN EN 1264

Room temp. °C	Supply temp. °C	Living area													Peripheral zone														
		25	30	35	40	45	50	55	60	65	70	75	80	85	90	95	100	105	110	115	120	125	130	135	140	145			
		Heat flow density $\text{W/m}^2$ (spec. heat output $\text{W/m}^2$ )																											
		Avg. surface temp. °C																											
20	30	Installation spacing VA mm	225	225	150	150	150	150	75	75	75																		
		Max. heating circuit area $\text{m}^2$	25	22	18	16	14	10	8	7	5																		
		Max. heating circuit length m	119	105	127	114	101	74	114	101	74																		
20	35	Installation spacing VA mm	300	300	225	225	225	225	150	150	150	150	75	75	75	75	75	75	75	75	75	75	75	75	75	75	75	75	
		Max. heating circuit area $\text{m}^2$	30	28	25	22	20	18	17	15	14	13	10	9	8	7.5	7	5	4										
		Max. heating circuit length m	107	101	119	105	96	87	121	107	101	94	74	127	114	107	101	74	61										
20	40	Installation spacing VA mm	300	300	300	300	225	225	225	225	150	150	150	150	150	150	150	150	150	150	150	150	150	150	150	150	150	150	
		Max. heating circuit area $\text{m}^2$	34	33	30	28	26	24	21	19	17	16	15	14	13	12	11	10	9	8	7	6	5	4.5	4	3			
		Max. heating circuit length m	121	117	107	101	123	114	101	92	121	114	107	101	94	87	81	74	127	114	101	87	74	67	61	47			
20	43	Installation spacing VA mm	300	300	300	300	300	225	225	225	150	150	150	150	150	150	150	150	150	150	150	150	150	150	150	150	150	150	
		Max. heating circuit area $\text{m}^2$	36	35	34	33	30	28	26	24	22	18	17	16	15	14	13	12	11	10	9	8	7.5	7	6.5	6	5.5	5	
		Max. heating circuit length m	127	124	121	117	107	101	123	114	105	127	121	114	107	101	94	87	81	74	127	114	107	101	94	87	81	74	
		Avg. surface temp. °C																											
24	30	Installation spacing VA mm	150	75	75																								
		Max. heating circuit area $\text{m}^2$	12	7	6																								
		Max. heating circuit length m	87	101	87																								
24	35	Installation spacing VA mm		150	150	150	150	150	75	75	75	75																	
		Max. heating circuit area $\text{m}^2$		18	16	14	12	9	8	7	6	4.5																	
		Max. heating circuit length m		127	114	101	87	67	114	101	87	67																	
24	40	Installation spacing VA mm			150	150	150	150	150	150	150	75	75	75	75	75	75	75	75	75	75	75	75	75	75	75	75		
		Max. heating circuit area $\text{m}^2$			18	17	16	15	14	13	12	9	8	7	6.5	6	5.5	5	4.5										
		Max. heating circuit length m			127	121	114	107	101	94	87	127	114	101	94	87	81	74	67										
24	43	Installation spacing VA mm					150	150	150	150	150	150	150	150	150	75	75	75	75	75	75	75	75	75	75	75	75		
		Max. heating circuit area $\text{m}^2$					18	17	16	15	14	13	12	11	9	8	7.5	7	6.5	6	5.5	5							
		Max. heating circuit length m					127	121	114	107	101	94	87	81	127	114	107	101	94	87	81	74							

Data does not replace precise planning according to DIN EN 1264.

**Presumed marginal conditions:**

Pressure loss: max. 250 mbar  
 Sub insulation R/(U): 0.75  $\text{m}^2\text{K/W}$  / (1.33  $\text{W/m}^2\text{K}$ )

tu: 15 °C  
 Single connection length: 3 - 4 m

Limit curve living area/peripheral zone

# Performance diagrams

Vinyl, linoleum or parquet up to approx. 8 mm\*, heating pipes Ø = 16 mm

Surface cover resistance  $R_{\lambda} = 0.05 \text{ m}^2 \text{ K/W}$

Follow manufacturer's specifications

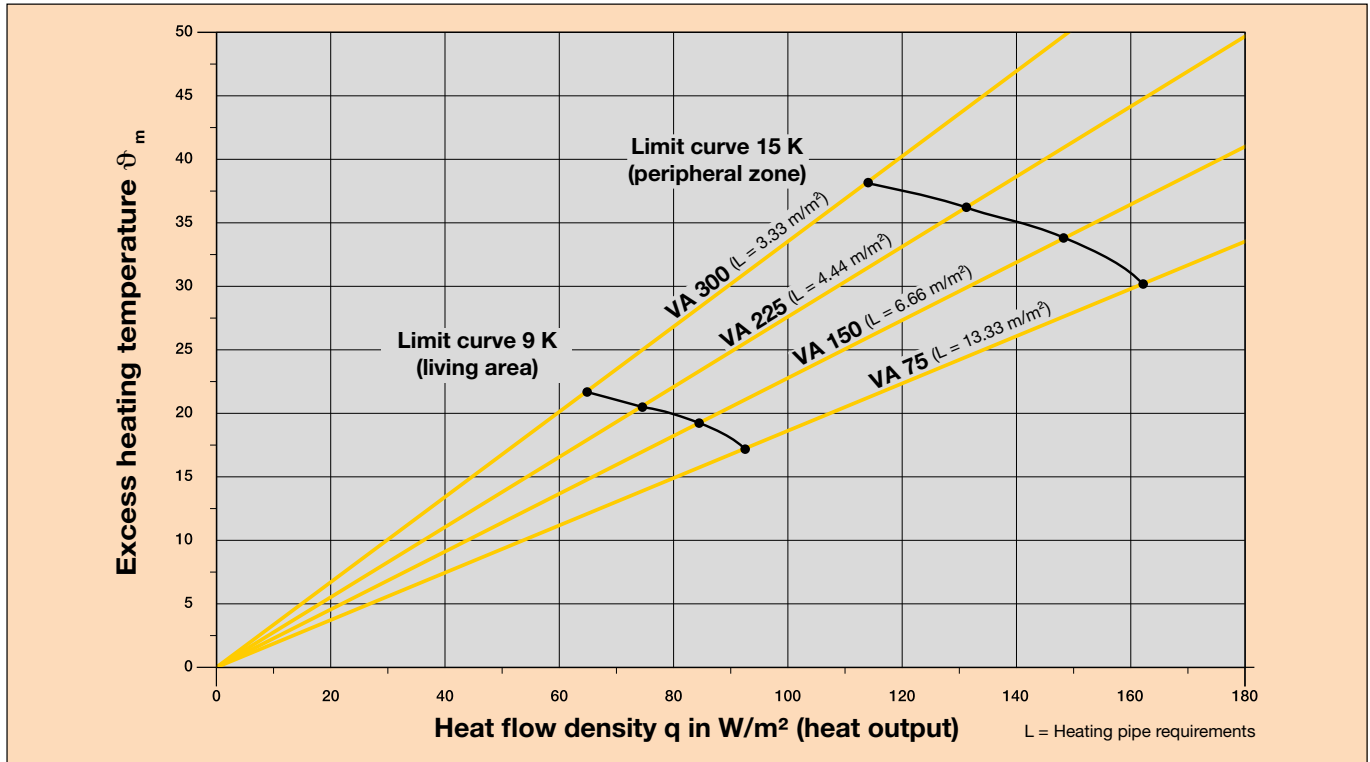

Performance data according to DIN EN 1264

Room temp. °C	Supply temp. °C	Living area														Peripheral zone												
		25	30	35	40	45	50	55	60	65	70	75	80	85	90	95	100	105	110	115	120	125	130	135	140	145		
Avg. surface temp. °C																												
Avg. surface temp. °C		22.7 23.6 24.5 25.5 26.4 27.3 28.2														29.1 30.0 30.9 31.8 32.7												
20	30	Installation spacing VA mm	150	150	150	75	75																					
		Max. heating circuit area m <sup>2</sup>	16	15	13	8	7																					
		Max. heating circuit length m	114	107	94	114	101																					
20	35	Installation spacing VA mm	300	300	225	225	150	150	75	75	75																	
		Max. heating circuit area m <sup>2</sup>	33	30	26	22	18	16	11	8	7	5																
		Max. heating circuit length m	117	107	123	105	127	114	81	114	101	74																
20	40	Installation spacing VA mm	300	300	300	300	225	225	150	150	150	150	75	75	75	75	75											
		Max. heating circuit area m <sup>2</sup>	35	33	28	25	23	21	18	17	15	13	10	8	7	6	5	4										
		Max. heating circuit length m	124	117	101	91	110	101	127	121	107	94	74	114	101	87	74	61										
20	43	Installation spacing VA mm	300	300	300	300	300	225	225	225	150	150	150	15	150	75	75	75	75	75								
		Max. heating circuit area m <sup>2</sup>	35	35	33	30	28	26	24	21	18	16	14	12	10	9	8	7	6	5	3.5							
		Max. heating circuit length m	124	124	117	107	101	123	114	105	127	114	101	87	74	127	114	101	87	74	54							
Avg. surface temp. °C		26.7 27.6 28.5 29.5 30.4 31.3 32.2														33.1 34.0 34.9												
24	30	Installation spacing VA mm	75																									
		Max. heating circuit area m <sup>2</sup>	7																									
		Max. heating circuit length m	101																									
24	35	Installation spacing VA mm		150	150	150	75	75																				
		Max. heating circuit area m <sup>2</sup>		13	12	10	8	6.5																				
		Max. heating circuit length m		114	87	74	114	94																				
24	40	Installation spacing VA mm				150	150	150	150	75	75	75																
		Max. heating circuit area m <sup>2</sup>				16	14	12	9	8	7	5																
		Max. heating circuit length m				114	101	87	67	114	101	74																
24	43	Installation spacing VA mm						150	150	150	75	75	75	75	75													
		Max. heating circuit area m <sup>2</sup>						16	14	12	9	8	7	6	5													
		Max. heating circuit length m						114	101	87	127	114	101	87	74													

Data does not replace precise planning according to DIN EN 1264.

Presumed marginal conditions:  
 Pressure loss: max. 250 mbar  
 Sub insulation R/(U): 0.75 m<sup>2</sup>KW / (1.33 W/m<sup>2</sup>K)

tu: 15 °C  
 Single connection length: 3 - 4 m







## Cooling output of BEKOTEC-EN P / -EN PF

### Notes:

- Average cooling output of 30 - 40 W/m<sup>2</sup> possible with ceramic coverings
- This lets the room temperature be lowered by approx. 3 °C
- Best cooling and heating values with ceramic coverings
- Normal cooling water temperature with approx. 18 °C.
- Ideal for use with heat pumps

The following performance data were determined in W/m<sup>2</sup> based on the installation spacing VA and the temperature difference  $\Delta T$  (room temperature cooling water temperature) according to DIN EN 1264.

### Heating pipe $\varnothing = 16$ mm

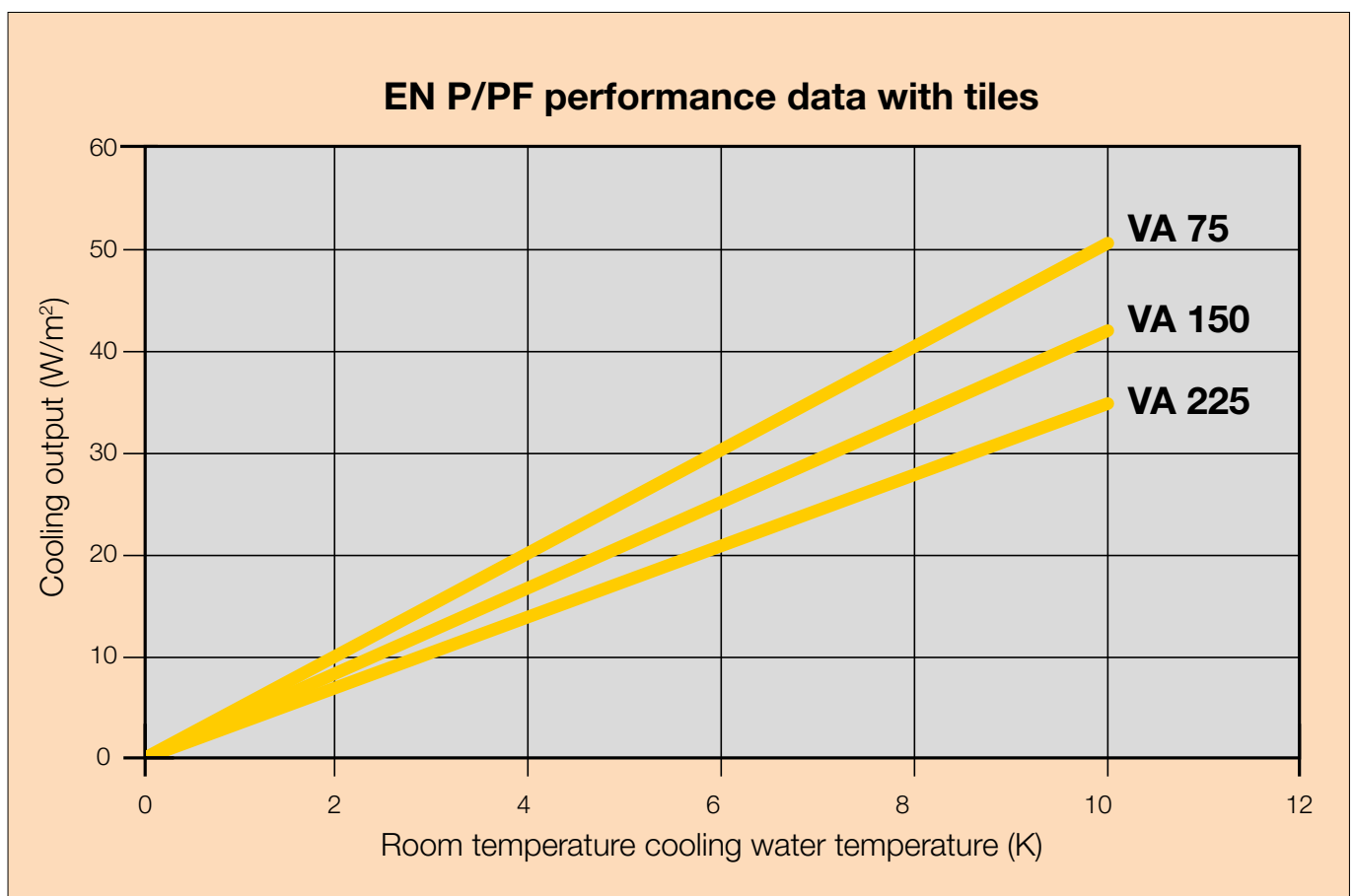

Performance data according to DIN EN 1264



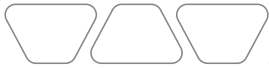

# Schlüter®-BEKOTEC-EN 23 F

The all-round talent



**BEKOTEC-EN 23 F** - suitable for conventional, semi-dry screeds and flowing screeds on cement or gypsum screeds

## Schlüter-BEKOTEC-EN 23 F at a glance

General product properties	
Material studded sheet	Polystyrene (PS) with 70% recycled content
Material thickness	1 mm
Panel height	23 mm
Width	1275 mm
Length	975 mm
Weight	1300 g
Working area	1.08 m <sup>2</sup> (1.2 x 0.9 m)
System data	
Weight per unit area with 8 mm coverage	57 kg/m <sup>2</sup>
Screed volume with 8 mm coverage	28.5 l/m <sup>2</sup>
Traffic load	up to 5 kN/m <sup>2</sup>
System heating pipes	diameter 14 mm silver grey
Heating pipe installation spacing	75/150/225/300 mm
Technical properties	
Density (structured polystyrene)	1.05 g/cm <sup>3</sup>
Resistance to temperature	-30 °C to +70 °C
Thermal conductivity	0.17 W/mK
Fire resistance class acc. to EN 13501-1	E
Certifications/approvals	
VOC (French regulation / EMICODE)	available (A+/EC 1 PLUS)

# Screed coverage and maximum traffic loads for various surface coverings

## Ceramic coverings

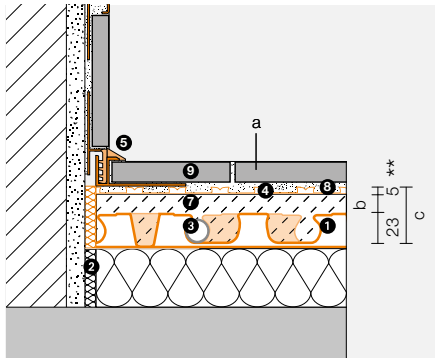

(a) Floor covering	Max. traffic load $q_k$ according to DIN EN 1991	Max. individual load $Q_k$ according to DIN EN 1991	(b) System coverage with conventional screeds	(c) Total thickness of BEKOTEC assembly
Ceramic tile/ natural stone	5.0 kN/m <sup>2</sup>	3.5 – 7.0 kN	8 – 25 mm	36 – 53 mm

\*\* Assembly height DITRA = 5 mm, see 4 for additional product specific assembly heights

## Non-ceramic coverings

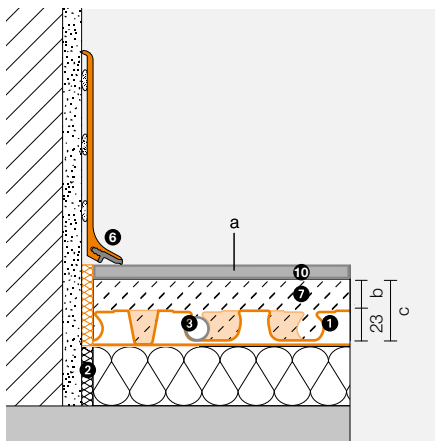

Loose or bonded soft coverings: PVC, vinyl, linoleum, carpet, cork	2 kN/m <sup>2</sup>	2.0 – 3.0 kN	15 – 25 mm	38 – 48 mm
Adhered parquet without tongue and groove connection	5.0 kN/m <sup>2</sup>	3.5 – 7.0 kN	15 – 25 mm	38 – 48 mm
Adhered parquet with tongue and groove connection	5.0 kN/m <sup>2</sup>	3.5 – 7.0 kN	8 – 25 mm	31 – 48 mm
Floating parquet, laminate and coverings with click system	2 kN/m <sup>2</sup>	2.0 – 3.0 kN	8 – 25 mm	31 – 48 mm

### System components

- 1 Schlüter®-BEKOTEC-EN 23 F  
Studded screed panel
- 2 Schlüter®-BEKOTEC-BRS 808 KSF  
Edging strip
- 3 Schlüter®-BEKOTEC-THERM-HR  
Heating pipe Ø 14 mm
- 4 Schlüter®-DITRA uncoupling mat  
Schlüter®-DITRA / -DITRA-PS  
(assembly height from 4 mm)  
or  
Schlüter®-DITRA-DRAIN 4  
(assembly height 6 mm)  
or  
Schlüter®-DITRA-HEAT / -DITRA-HEAT-PS  
(assembly height from 6 mm)
- 5 Schlüter®-DILEX -EK or -RF  
Maintenance free edge and movement joint profiles
- 6 Schlüter®-DESIGNBASE-SL, -QD  
Decorative finishing profiles for walls, skirting and floors
- 7 Screed  
based on conventionally applied cement or gypsum screeds  
(see specification on page 32)
- 8 Thin bed tile adhesive
- 9 Ceramic tiles or natural stone
- 10 non-ceramic coverings  
Other coverings (see table) are also feasible in compliance with the applicable installation standards.



# General information on substrates/raw ceilings, preparatory work and insulation layers

## Substrate:

- Load-bearing
- Clean
- Level
- Correct uneven sections in the floor with screeds or suitable bound fill in advance.

**Bound fills:** Bound fills are permitted

**Heat insulation:** Additional layers of insulation are permitted.

**Sound insulation:** Only one layer of sound insulation is permissible, max. compressibility of CP3 ( $\leq 3$  mm).

**If using flowing screeds, installation of a PE separating layer on insulation materials is recommended.**

## Edging strips for BEKOTEC-EN 23 F

	<b>BRS 810</b> for traditional semi-dry screeds only Height: 100 mm, thickness: 8 mm	<b>BRSK 810</b> for traditional semi-dry screeds only Height: 100 mm, thickness: 8 mm	<b>BRS 808 KF</b> for traditional semi-dry screeds and flowing screeds Height: 80 mm, thickness: 8 mm	<b>BRS 808 KSF</b> for traditional semi-dry screeds and flowing screeds Height: 80 mm, thickness: 8 mm
<b>EN 23 F</b>	-	-	-	<b>X</b>

## Installation of the studded screed panel

The installation direction is indicated by the tapered connection studs, which are shown in green colour in the drawing. Cut segments that are longer than  $\geq 30$  cm can fit into the next row. Remaining areas or cut outs at doors and protrusions and near distributor boxes can be covered with the levelling panel Schlüter-BEKOTEC-ENFG.

**Important:** With flowing screeds, the panel abutting joints must be tightly sealed, e.g. with adhesive tape!

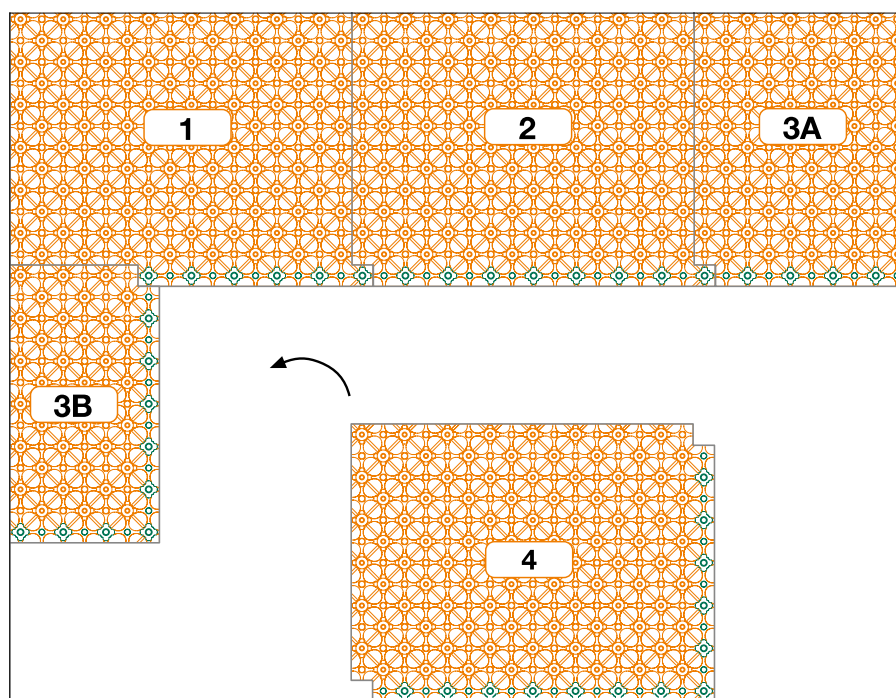

Laying out and fitting the studded screed panel Schlüter-BEKOTEC-EN 23 F

Installation process (with optimal use of material)

## Heating pipe installation

The system heating pipes (Ø 14 mm) are installed at double the installation spacing to the reversal loop. After the reversal loop, insert the return line (blue) into the centre of the remaining space.

**Important:** Form the heating pipes as shown in the drawing!

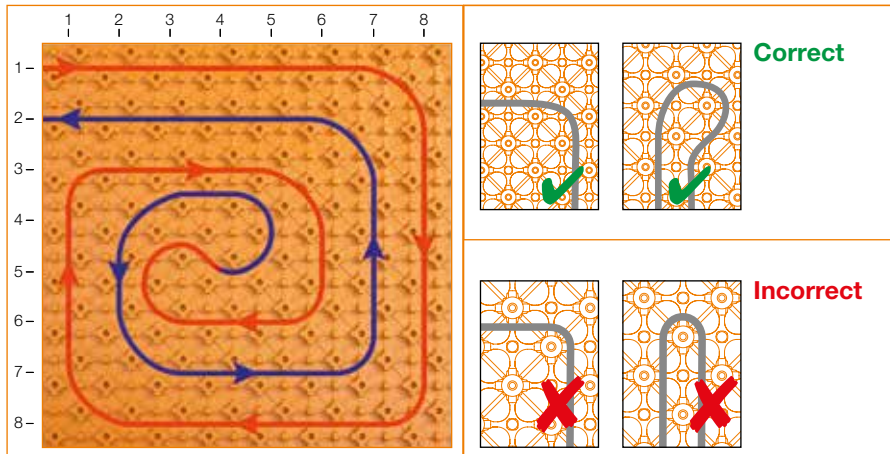

The spacing of the pipes must be determined on the basis of the required heating output and cooling output (see pages 64 - 68).

**Important:** Before and during the installation of the screed, the studded panel may need to be protected from mechanical damage with suitable measures, such as laying out wooden boards.

## Levelling panel

The levelling panel Schlüter-BEKOTEC-ENFG is installed in the area of the heating circuit distributors and at thresholds to simplify connections and to minimise cutting waste. It consists of smooth polystyrene foil material and is adhered below the studded panels, using the supplied double sided adhesive tape.

### Technical data

**Dimensions:** 1275 x 975 = 1.24 m<sup>2</sup>

**Thickness:** 1.0 mm



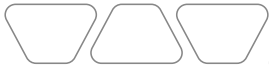

# Performance diagrams

Ceramic thermal comfort floor, heating pipes  $\varnothing = 14$  mm

Floor covering: **ceramic tile, natural stone, cast stone** incl. Schlüter-DITRA mat.

Surface cover resistance  $R_{\lambda} = 0.00$  m<sup>2</sup> K/W

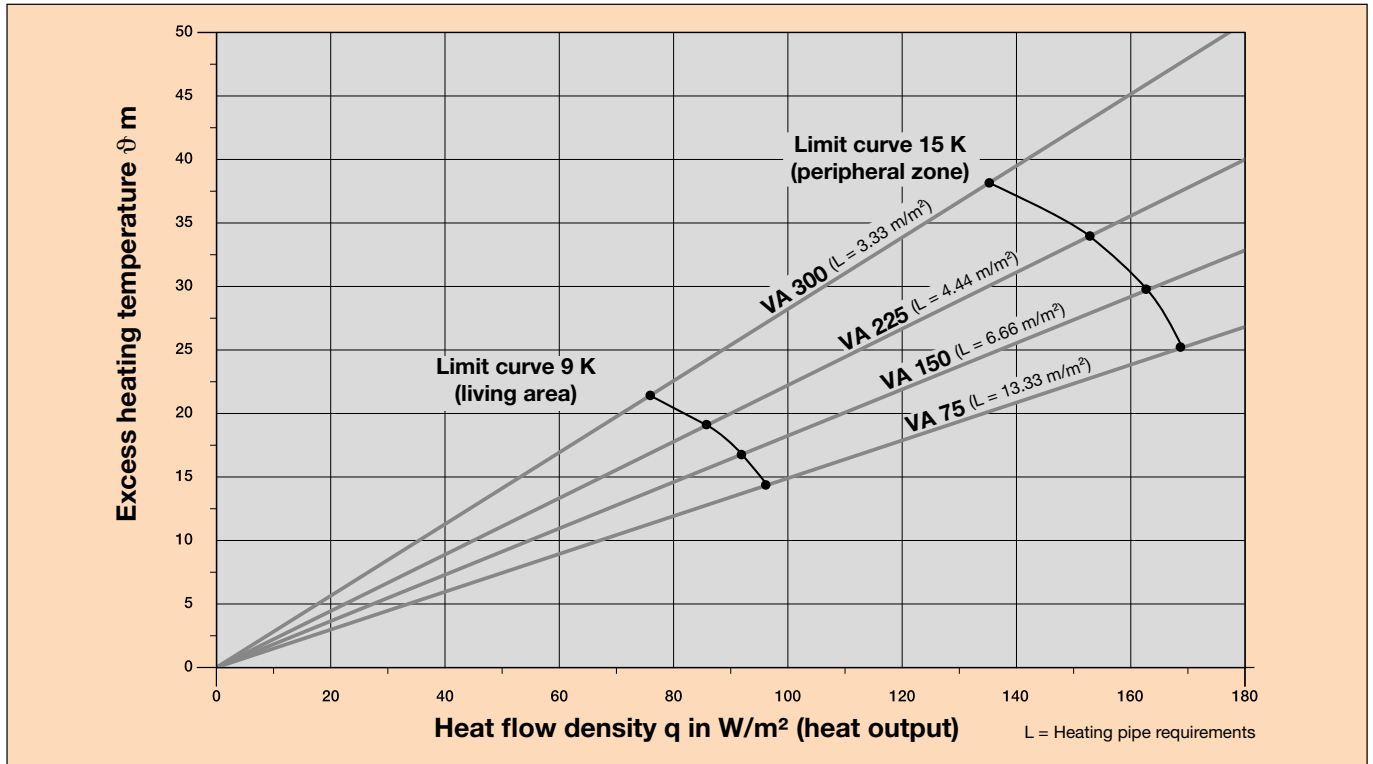

Performance data according to DIN EN 1264

Room temp. °C	Supply temp. °C		Living area													Peripheral zone												
			25	30	35	40	45	50	55	60	65	70	75	80	85	90	95	100	105	110	115	120	125	130	135	140	145	
		Heat flow density W/m <sup>2</sup> (spec. heat output W/m <sup>2</sup> )	25	30	35	40	45	50	55	60	65	70	75	80	85	90	95	100	105	110	115	120	125	130	135	140	145	
		Avg. surface temp. °C	22.7	23.6	24.5	25.5	26.4	27.3	28.2									29.1	30.0	30.9	31.8	32.7						
20	30	Installation spacing VA mm	225	225	150	150	150	75	75	75																		
		Max. heating circuit area m <sup>2</sup>	19	16	14	12	9	7	5	4																		
		Max. heating circuit length m	92	78	101	87	67	101	74	61																		
20	35	Installation spacing VA mm	225	225	225	225	225	150	150	150	150	75	75	75	75	75	75	75										
		Max. heating circuit area m <sup>2</sup>	24	22	20	18	16	15	14	12	10	7.5	7	6	5.5	5	4	3.5										
		Max. heating circuit length m	114	105	96	87	79	107	101	87	74	57	101	87	81	74	61	54										
20	40	Installation spacing VA mm	300	300	300	300	225	225	150	150	150	150	150	150	150	150	75	75	75	75	75	75	75	75	75	75	75	
		Max. heating circuit area m <sup>2</sup>	30	27	25	23	20	18	16	15	14	13	12	11	9	8	8	7	6.5	6	5.5	5	4.5	3.5				
		Max. heating circuit length m	107	97	91	84	96	87	114	107	101	94	87	81	67	61	114	101	94	87	81	74	67	54				
20	43	Installation spacing VA mm	300	300	300	300	300	225	225	225	225	150	150	150	150	150	150	150	150	75	75	75	75	75	75	75	75	
		Max. heating circuit area m <sup>2</sup>	33	30	28	26	24	24	22	20	18	16	14	13	12	11	10	9	8	7	6.5	6	5	4.5	4	3.5		
		Max. heating circuit length m	117	107	101	94	87	114	105	96	87	114	101	94	87	81	74	67	61	114	101	94	87	74	67	61	54	
		Avg. surface temp. °C	26.7	27.6	28.5	29.5	30.4	31.3	32.2									33.1	34.0	34.9								
24	30	Installation spacing VA mm	75	75	75																							
		Max. heating circuit area m <sup>2</sup>	5.5	5	4																							
		Max. heating circuit length m	81	74	61																							
24	35	Installation spacing VA mm			150	150	150	150	75	75	75	75	75															
		Max. heating circuit area m <sup>2</sup>			14	12	10	8	7	6	5.5	4	2.5															
		Max. heating circuit length m			101	87	74	61	101	87	81	61	41															
24	40	Installation spacing VA mm				150	150	150	150	150	150	75	75	75	75	75	75	75	75	75	75	75	75	75	75	75		
		Max. heating circuit area m <sup>2</sup>				16	15	14	12	11	10	9	7	6.5	6	5.5	5	4	3	2.5								
		Max. heating circuit length m				114	107	101	87	81	74	67	101	94	87	81	74	61	47	41								
24	43	Installation spacing VA mm						150	150	150	150	150	150	150	75	75	75	75	75	75	75	75	75	75	75	75		
		Max. heating circuit area m <sup>2</sup>						16	15	14	13.5	12	11	10	9	8	7.5	7	6.5	6	5	4						
		Max. heating circuit length m						114	107	101	97	87	81	74	67	114	107	101	94	87	74	61						

Limit curve living area/peripheral zone

Data does not replace precise planning according to DIN EN 1264.

**Presumed marginal conditions:**

Pressure loss: max. 250 mbar  
 Sub insulation R/(U): 0.75 m<sup>2</sup>KW / (1.33 W/m<sup>2</sup>K)

tu: 15 °C  
 Single connection length: 3 - 4 m

# Performance diagrams

Vinyl, linoleum or parquet up to approx. 8 mm, heating pipes Ø = 14 mm

Floor covering: Vinyl, linoleum or parquet up to approx. 8 mm (observe manufacturer recommendations).

Surface cover resistance  $R_{\lambda} = 0.05 \text{ m}^2 \text{ K/W}$

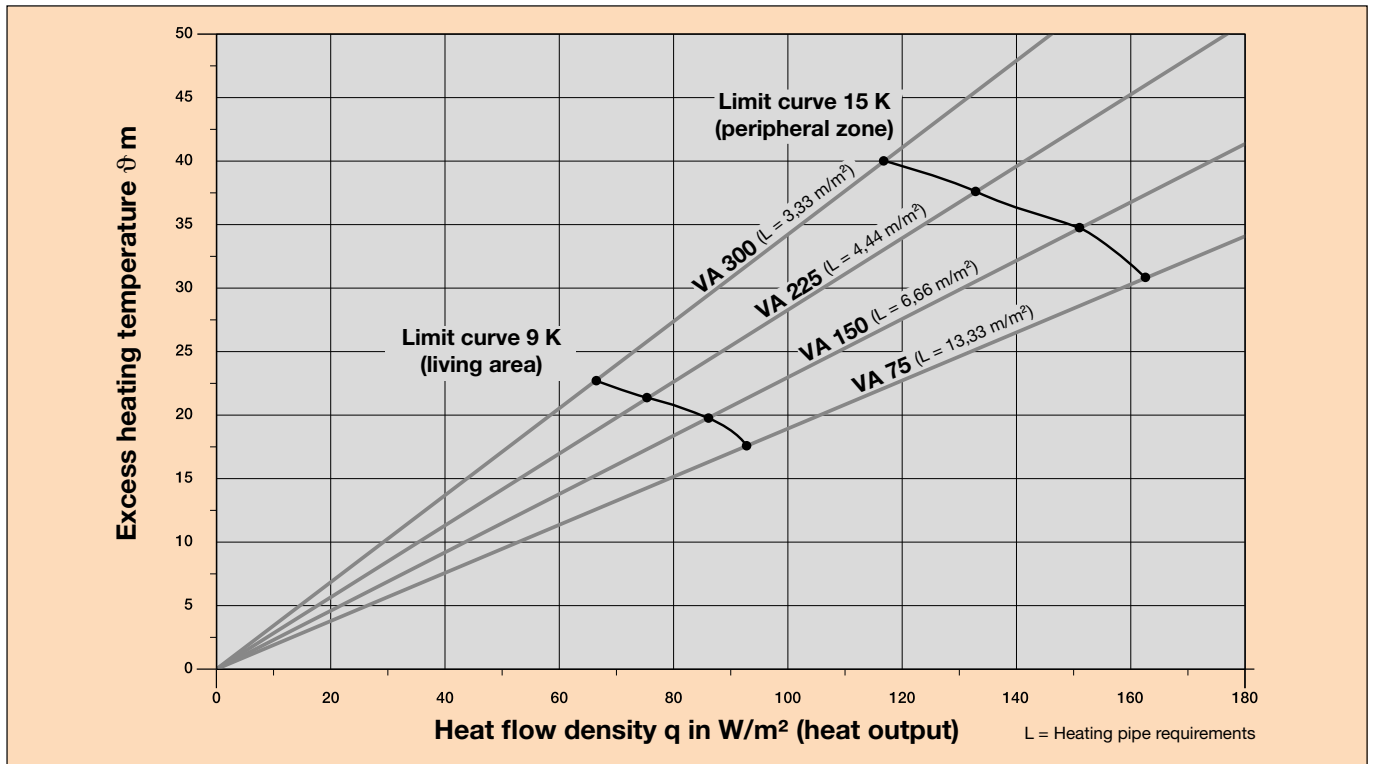

Performance data according to DIN EN 1264

Room temp. °C	Supply temp. °C		Living area													Peripheral zone											
			25	30	35	40	45	50	55	60	65	70	75	80	85	90	95	100	105	110	115	120	125	130	135	140	145
		Heat flow density $\text{W/m}^2$ (spec. heat output $\text{W/m}^2$ )																									
		Avg. surface temp. °C																									
20	30	Installation spacing VA mm	150	150	150	75	75																				
		Max. heating circuit area $\text{m}^2$	13	12	8	6	4.5																				
		Max. heating circuit length m	94	87	61	87	67																				
20	35	Installation spacing VA mm	300	225	225	225	150	150	75	75	75	75															
		Max. heating circuit area $\text{m}^2$	26	24	20	18	14	11	8	7	6	3.5															
		Max. heating circuit length m	94	114	96	87	101	81	114	101	87	54															
20	40	Installation spacing VA mm	300	300	300	225	225	225	150	150	150	150	75	75	75	75	75										
		Max. heating circuit area $\text{m}^2$	28	25	24	22	20	17	15	13	11	8	8	7	6	5	3										
		Max. heating circuit length m	101	91	87	105	96	83	107	94	81	61	114	101	87	74	47										
20	43	Installation spacing VA mm	300	300	300	300	225	225	225	150	150	150	150	150	75	75	75	75	75								
		Max. heating circuit area $\text{m}^2$	30	28	26	24	22	20	18	16	14	13	11	8.5	7.5	7	6	5	4								
		Max. heating circuit length m	107	101	94	87	105	96	87	114	101	94	81	64	107	101	87	74	61								
		Avg. surface temp. °C																									
24	30	Installation spacing VA mm	75																								
		Max. heating circuit area $\text{m}^2$	6																								
		Max. heating circuit length m	87																								
24	35	Installation spacing VA mm	150	150	75	75	75	75																			
		Max. heating circuit area $\text{m}^2$	13	10	8	6	4	3																			
		Max. heating circuit length m	94	74	114	87	61	47																			
24	40	Installation spacing VA mm				150	150	150	75	75	75	75															
		Max. heating circuit area $\text{m}^2$				13	11	8	7	6	5	3															
		Max. heating circuit length m				94	81	61	101	87	74	47															
24	43	Installation spacing VA mm							150	150	150	75	75	75	75	75											
		Max. heating circuit area $\text{m}^2$							13	11	9	7.5	6.5	5.5	5	3											
		Max. heating circuit length m							94	81	67	107	94	81	74	47											

Data does not replace precise planning according to DIN EN 1264.

Presumed marginal conditions:  
 Pressure loss: max. 250 mbar  
 Sub insulation R/(U): 0.75  $\text{m}^2\text{K/W}$  / (1.33  $\text{W/m}^2\text{K}$ )

tu: 15 °C  
 Single connection length: 3 - 4 m

Limit curve living area/peripheral zone







## Cooling output of BEKOTEC-EN 23 F

### Notes:

- Average cooling output of 30 - 40 W/m<sup>2</sup> possible with ceramic coverings
- This lets the room temperature be lowered by approx. 3 °C
- Best cooling and heating values with ceramic coverings
- Normal cooling water temperature with approx. 18 °C.
- Ideal for use with heat pumps

The following performance data were determined in W/m<sup>2</sup> based on the installation spacing VA and the temperature difference  $\Delta T$  (room temperature cooling water temperature) according to DIN EN 1264.

### Heating pipe $\varnothing = 14$ mm

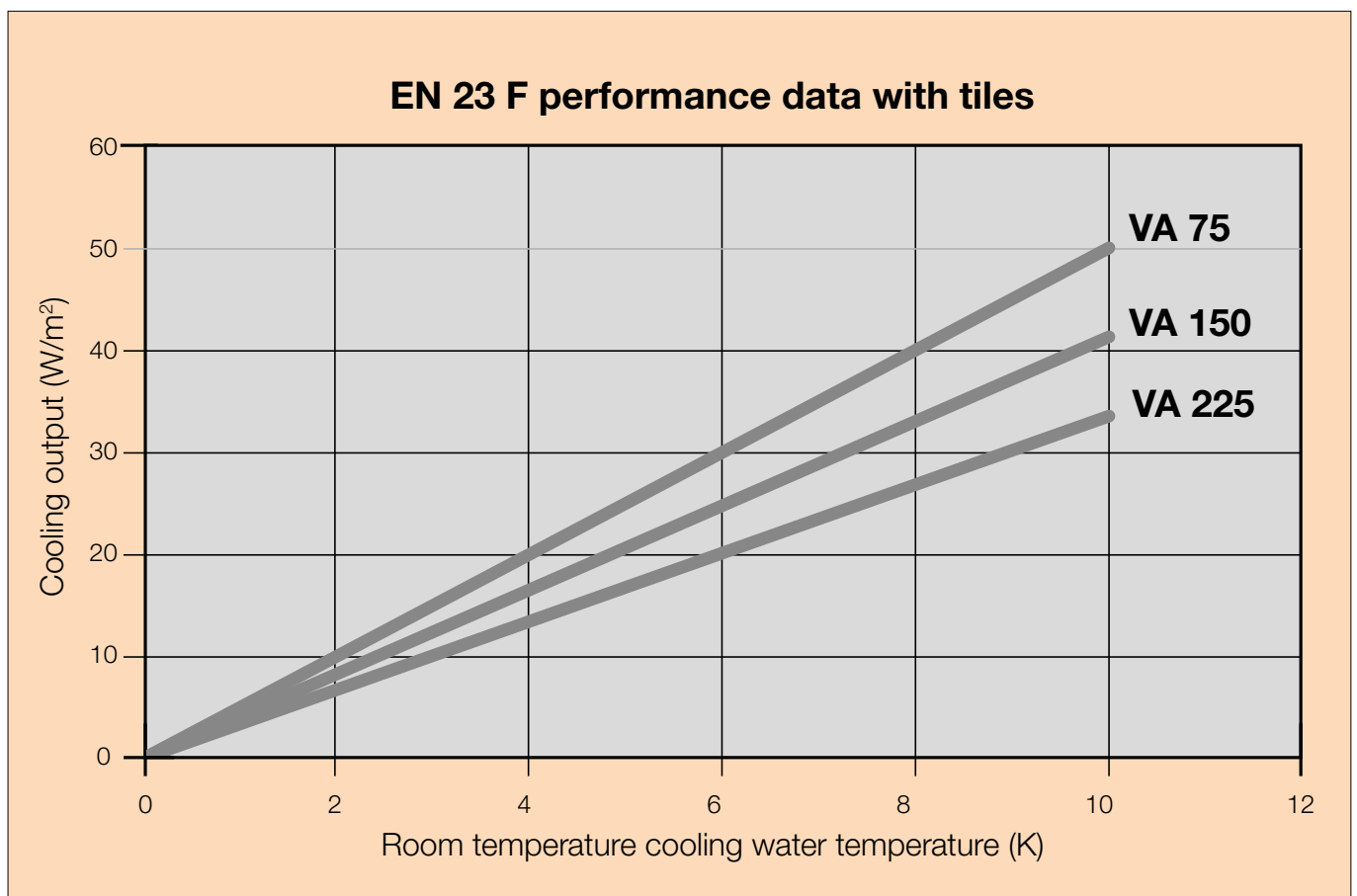

Performance data according to DIN EN 1264

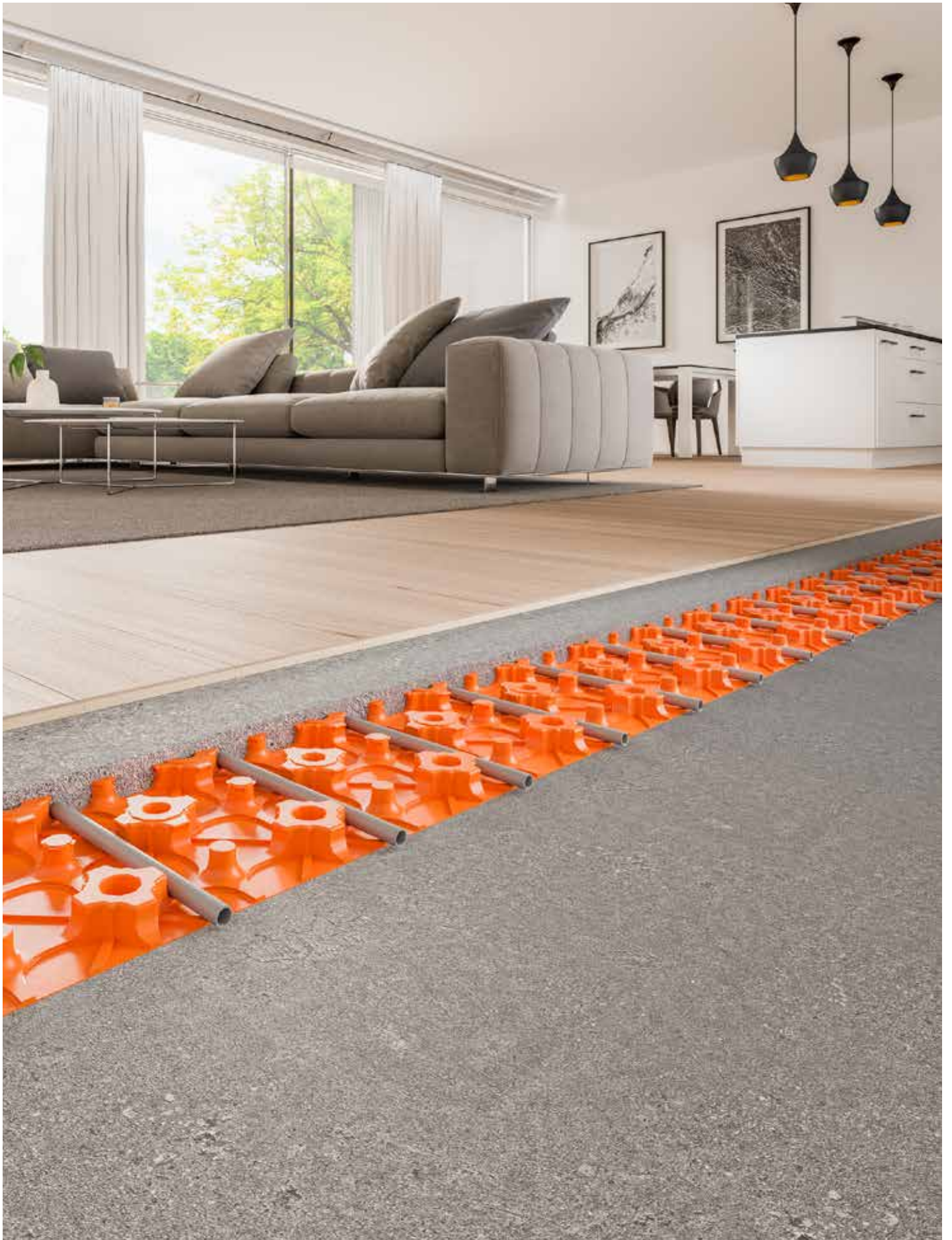



# Schlüter®-BEKOTEC-EN 23 F PS

The self-adhesive all-rounder



**BEKOTEC-EN 23 F PS** - suitable for conventional, semi-dry screeds and flowing screeds on cement or gypsum screeds.

## Schlüter-BEKOTEC-EN 23 F PS at a glance

General product properties	
Material studded sheet	Polystyrene (PS) with 70% recycled content
Adhesive layer PSA Hotmelt	Adhesive layer PSA Hotmelt
Protective foil PE, transparent	Protective foil PE, transparent
Material thickness	1 mm
Panel height	23 mm
Width	1275 mm
Length	975 mm
Weight	1490 g
Working area	1.08 m <sup>2</sup> (1.2 x 0.9 m)
Storage conditions	Store in a frost-free and UV-protected location, temperatures may not exceed 70 degrees C for an extended period
System data	
Weight per unit area with 8 mm coverage	57 kg/m <sup>2</sup>
Screed volume with 8 mm coverage	28.5 l/m <sup>2</sup>
Traffic load	up to 5 kN/m <sup>2</sup>
System heating pipes	diameter 14 mm silver grey diameter 16 mm orange
Heating pipe installation spacing	75/150/225/300 mm
Technical properties	
Density (structured polystyrene)	1.05 g/cm <sup>3</sup>
Resistance to temperature	-30 °C to +70 °C
Thermal conductivity	0.17 W/mK
Fire resistance class acc. to EN 13501-1	E
Certifications/approvals	
VOC (French regulation / EMI CODE)	available (A+/EC 1 PLUS)

# Screed coverage and maximum traffic loads for various surface coverings

## Ceramic coverings

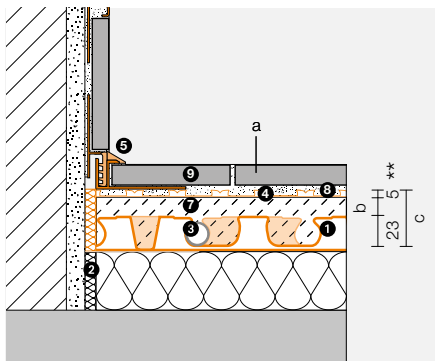

(a) Floor covering	Max. traffic load $q_k$ according to DIN EN 1991	Max. individual load $Q_k$ according to DIN EN 1991	(b) System coverage with conventional screeds	(c) Total thickness of BEKOTEC assembly
Ceramic tile/natural stone	5.0 kN/m <sup>2</sup>	3.5 – 7.0 kN	8 – 25 mm	36 – 53 mm

\*\* Assembly height DITRA = 5 mm, see 4 for additional product specific assembly heights

## Non-ceramic coverings

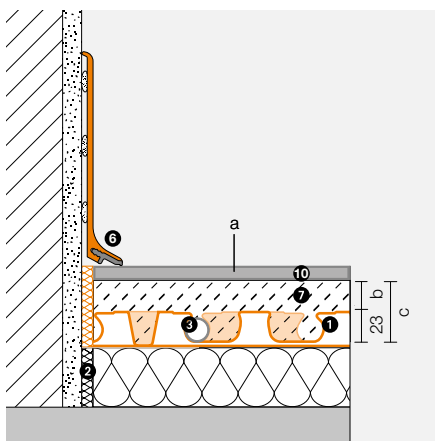

Loose or bonded soft coverings: PVC, vinyl, linoleum, carpet, cork	2 kN/m <sup>2</sup>	2.0 – 3.0 kN	15 – 25 mm	38 – 48 mm
Adhered parquet without tongue and groove connection	5.0 kN/m <sup>2</sup>	3.5 – 7.0 kN	15 – 25 mm	38 – 48 mm
Adhered parquet with tongue and groove connection	5.0 kN/m <sup>2</sup>	3.5 – 7.0 kN	8 – 25 mm	31 – 48 mm
Floating parquet, laminate and coverings with click system	2 kN/m <sup>2</sup>	2.0 – 3.0 kN	8 – 25 mm	31 – 48 mm

### System components)

- 1 Schlüter®-BEKOTEC-EN 23 F PS  
Studded screed panel
- 2 Schlüter®-BEKOTEC-BRS 808 KSF  
Edging strip
- 3 Schlüter®-BEKOTEC-THERM-HR  
Heating pipe Ø 14 mm
- 4 Schlüter®-DITRA uncoupling mat  
Schlüter®-DITRA / -DITRA-PS  
(assembly height from 4 mm)  
or  
Schlüter®-DITRA-DRAIN 4  
(assembly height 6 mm)  
or  
Schlüter®-DITRA-HEAT / -DITRA-HEAT-PS  
(assembly height from 6 mm)
- 5 Schlüter®-DILEX -EK or -RF  
Maintenance free edge and movement joint profiles
- 6 Schlüter®-DESIGNBASE-SL, -QD  
Decorative finishing profiles for walls, skirting and floors
- 7 Screed  
based on conventionally applied cement or gypsum screeds  
(see specification on page 32)
- 8 Thin bed tile adhesive
- 9 Ceramic tiles or natural stone
- 10 non-ceramic coverings  
Other coverings (see table) are also feasible in compliance with the applicable installation standards.

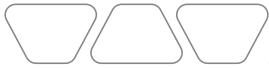

## General information on substrates/raw ceilings, preparatory work and insulation layers

### Substrate:

- Load-bearing
- Clean
- Level
- Correct uneven sections in the floor with screeds or compensating masses in advance.
- It is not mandatory, but possible to apply a primer

**Bound fills:** Bound, adhesive-friendly and scratch-resistant bound fills are permitted.

**Heat insulation:** Additional layers of polystyrene or polyurethane insulation permitted.

**Sound insulation:** Only one layer of polystyrene or polyurethane sound insulation is permissible. Max. compressibility CP3 ( $\leq 3$  mm).

**Important:** Although it is not mandatory to apply a primer, a standard primer without coarse components such as quartz sand may be used if the condition of the substrate necessitates it.

Insulation materials with a nominal thickness under 20 mm may lead to higher restoring forces within the assembly (insulation layer and studded panel in conjunction with heating pipe).

### Edging strips for BEKOTEC-EN 23 F PS

				
	<b>BRS 810</b> for traditional semi-dry screeds only Height: 100 mm, thickness: 8 mm	<b>BRSK 810</b> for traditional semi-dry screeds only Height: 100 mm, thickness: 8 mm	<b>BRS 808 KF</b> for traditional semi-dry screeds and flowing screeds Height: 80 mm, thickness: 8 mm	<b>BRS 808 KSF</b> for traditional semi-dry screeds and flowing screeds Height: 80 mm, thickness: 8 mm
<b>EN 23 F PS</b>	–	–	–	<b>X</b>

### Installation of the studded screed panel

The installation direction is indicated by the tapered connection studs, which are shown in green colour in the drawing. Cut segments that are longer than  $\geq 30$  cm can fit into the next row. Remaining areas or cut outs at doors and protrusions and near distributor boxes can be covered with the leveling panel Schlüter-BEKOTEC-ENFG PS. The BEKOTEC-EN 23 F PS studded panels must be precisely cut to size in the edge areas. The BEKOTEC panels are connected by overlapping a row of studs. To install the studded panel, peel the release film off BEKOTEC-EN 23 F PS and place the panel on the substrate. It can be lifted and re-positioned providing no pressure has been applied to it. However, the pressure sensitive adhesive on the underside will firmly stick the studded panel to the substrate once pressure has been applied.

**Important:** With flowing screeds, the panel abutting joints must be tightly sealed, e.g. with adhesive tape!

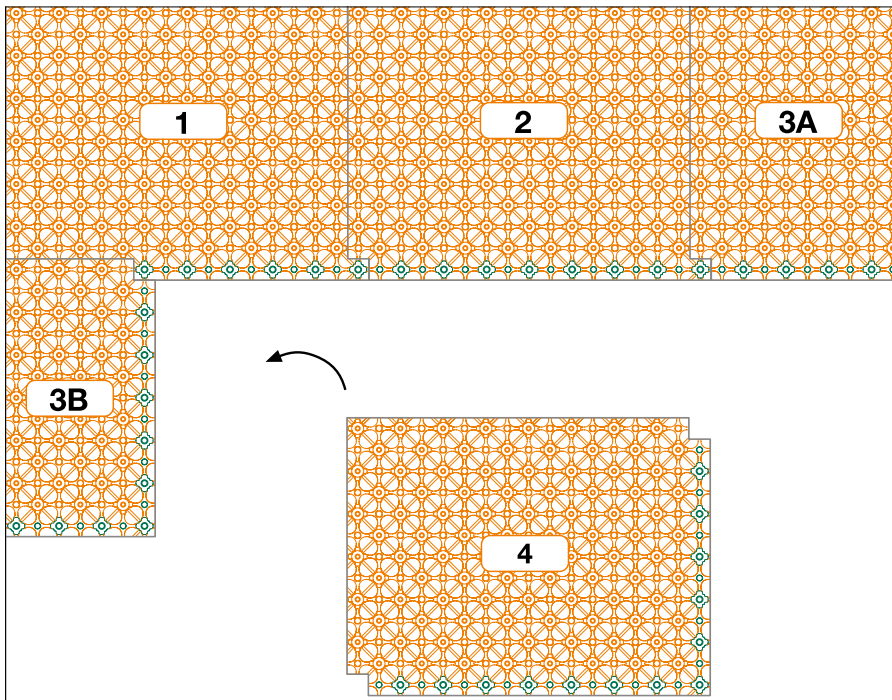

Installation process (with optimal use of material)



Laying out and fitting the  
studded screed panel  
Schlüter-BEKOTEC-EN 23 F PS

**Important:** With flowing screeds, the panel abutting joints must be tightly sealed, e.g. with adhesive tape!

### Heating pipe installation

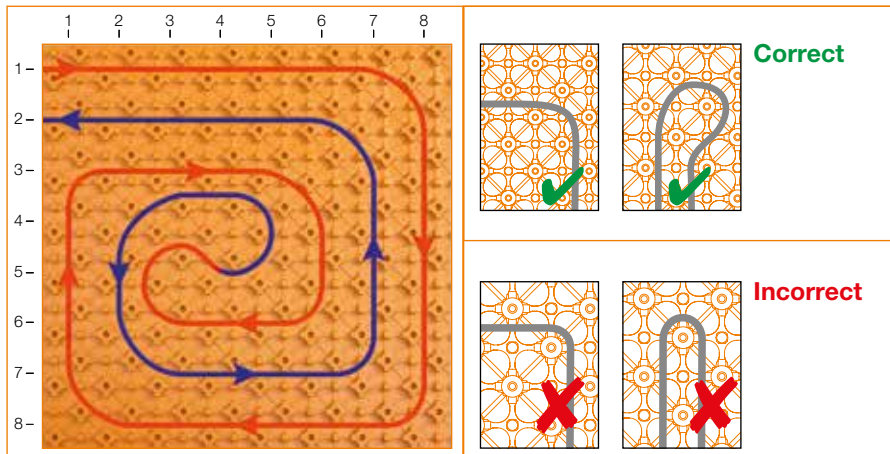

The system heating pipes (Ø 14 mm or 16 mm) are installed at double the installation spacing to the reversal loop. After the reversal loop, insert the return line (blue) into the centre of the remaining space.

**Important:** Form the heating pipes as shown in the drawing!

The spacing of the pipes must be determined on the basis of the required heating output and cooling output (see pages 74 - 83).

**Important:** Before and during the installation of the screed, the studded panel may need to be protected from mechanical damage with suitable measures, such as laying out wooden boards.

### Levelling panel

The levelling panel Schlüter-BEKOTEC-ENFG PS is installed in the area of the heating circuit distributors and at thresholds to simplify connections and to minimise cutting waste. It consists of smooth polystyrene foil material and is adhered below the studded panels, using the supplied double sided adhesive tape.

#### Technical data

**Dimensions:** 1275 x 975 = 1.24 m<sup>2</sup>

**Thickness:** 1.2 mm





# Performance diagrams

Ceramic thermal comfort floor, heating pipes  $\varnothing = 16 \text{ mm}$

Floor covering: ceramic tile, natural stone, cast stone incl. Schlüter-DITRA mat.

Surface cover resistance  $R_{\lambda} = 0.00 \text{ m}^2 \text{ K/W}$

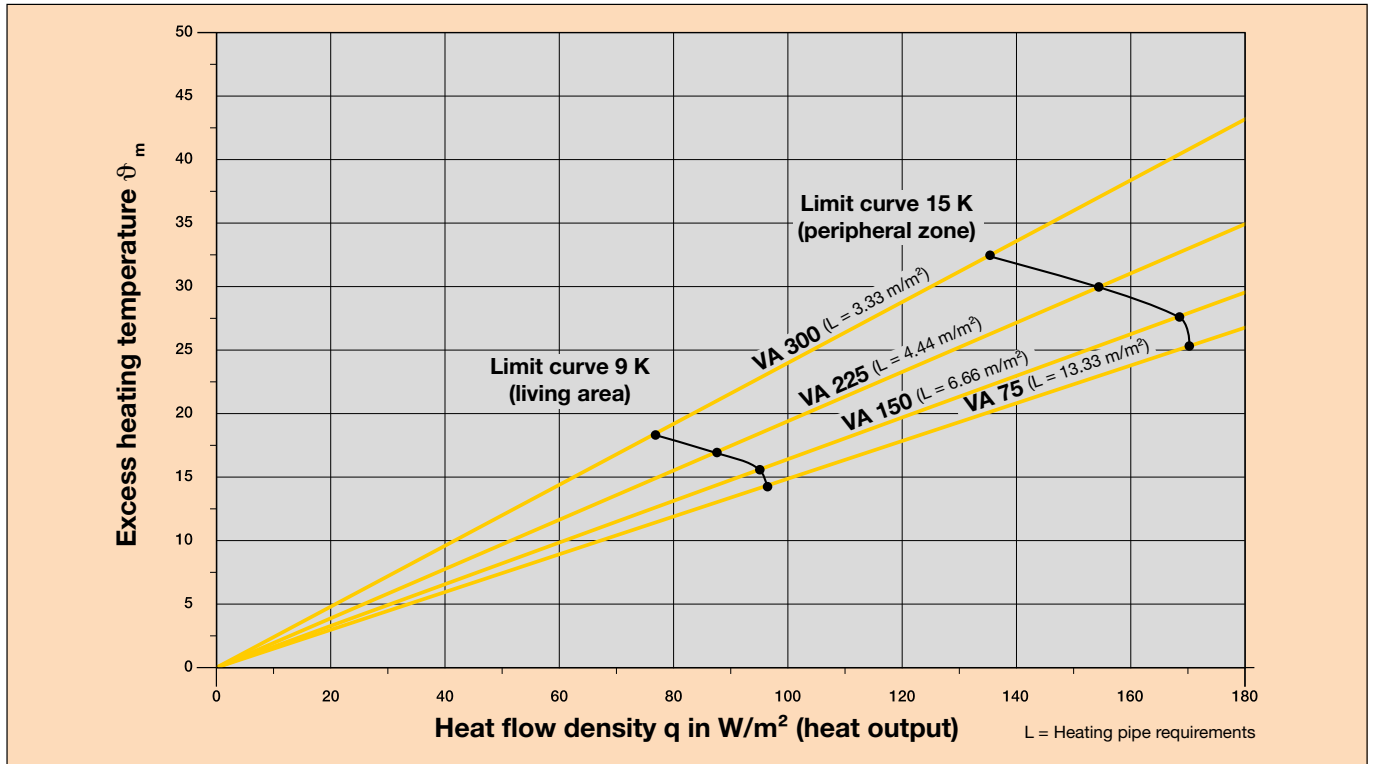

Performance data according to DIN EN 1264

Room temp. °C	Supply temp. °C	Living area													Peripheral zone														
		25	30	35	40	45	50	55	60	65	70	75	80	85	90	95	100	105	110	115	120	125	130	135	140	145			
		Heat flow density $\text{W/m}^2$ (spec. heat output $\text{W/m}^2$ )																											
		Avg. surface temp. °C																											
20	30	Installation spacing VA mm	225	225	150	150	150	150	75	75	75																		
		Max. heating circuit area $\text{m}^2$	25	22	18	16	14	10	8	7	5																		
		Max. heating circuit length m	119	105	127	114	101	74	114	101	74																		
20	35	Installation spacing VA mm	300	300	225	225	225	225	150	150	150	150	75	75	75	75	75	75	75	75	75	75	75	75	75	75	75	75	
		Max. heating circuit area $\text{m}^2$	30	28	25	22	20	18	17	15	14	13	10	9	8	7.5	7	5	4										
		Max. heating circuit length m	107	101	119	105	96	87	121	107	101	94	74	127	114	107	101	74	61										
20	40	Installation spacing VA mm	300	300	300	300	225	225	225	225	150	150	150	150	150	150	150	150	150	150	150	150	150	150	150	150	150	150	
		Max. heating circuit area $\text{m}^2$	34	33	30	28	26	24	21	19	17	16	15	14	13	12	11	10	9	8	7	6	5	4.5	4	3			
		Max. heating circuit length m	121	117	107	101	123	114	101	92	121	114	107	101	94	87	81	74	127	114	101	87	74	67	61	47			
20	43	Installation spacing VA mm	300	300	300	300	300	225	225	225	150	150	150	150	150	150	150	150	150	150	150	150	150	150	150	150	150	150	
		Max. heating circuit area $\text{m}^2$	36	35	34	33	30	28	26	24	22	18	17	16	15	14	13	12	11	10	9	8	7.5	7	6.5	6	5.5	5	
		Max. heating circuit length m	127	124	121	117	107	101	123	114	105	127	121	114	107	101	94	87	81	74	127	114	107	101	94	87	81	74	
		Avg. surface temp. °C																											
24	30	Installation spacing VA mm	150	75	75																								
		Max. heating circuit area $\text{m}^2$	12	7	6																								
		Max. heating circuit length m	87	101	87																								
24	35	Installation spacing VA mm		150	150	150	150	150	75	75	75	75																	
		Max. heating circuit area $\text{m}^2$		18	16	14	12	9	8	7	6	4.5																	
		Max. heating circuit length m		127	114	101	87	67	114	101	87	67																	
24	40	Installation spacing VA mm			150	150	150	150	150	150	150	75	75	75	75	75	75	75	75	75	75	75	75	75	75	75	75		
		Max. heating circuit area $\text{m}^2$			18	17	16	15	14	13	12	9	8	7	6.5	6	5.5	5	4.5										
		Max. heating circuit length m			127	121	114	107	101	94	87	127	114	101	94	87	81	74	67										
24	43	Installation spacing VA mm					150	150	150	150	150	150	150	150	75	75	75	75	75	75	75	75	75	75	75	75	75		
		Max. heating circuit area $\text{m}^2$					18	17	16	15	14	13	12	11	9	8	7.5	7	6.5	6	5.5	5							
		Max. heating circuit length m					127	121	114	107	101	94	87	81	127	114	107	101	94	87	81	74							

Data does not replace precise planning according to DIN EN 1264.

**Presumed marginal conditions:**

Pressure loss: max. 250 mbar  
 Sub insulation R/(U): 0.75  $\text{m}^2\text{K/W}$  / (1.33  $\text{W/m}^2\text{K}$ )

tu: 15 °C  
 Single connection length: 3 - 4 m

Limit curve living area/peripheral zone

# Performance diagrams

Vinyl, linoleum or parquet up to approx. 8 mm\*, heating pipes Ø = 16 mm

Surface cover resistance  $R_{\lambda} = 0.05 \text{ m}^2 \text{ K/W}$

Follow manufacturer's specifications

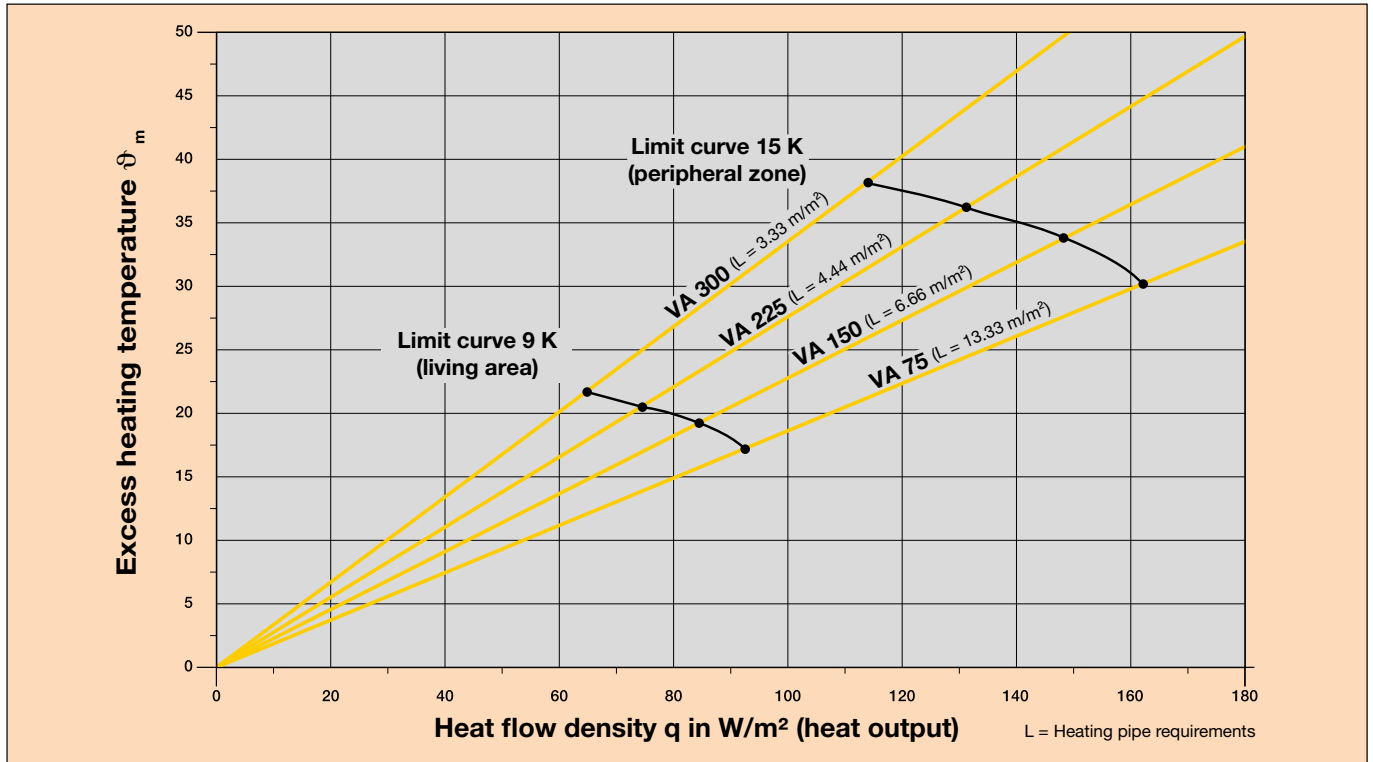

Performance data according to DIN EN 1264

Room temp. °C	Supply temp. °C		Living area													Peripheral zone													
			25	30	35	40	45	50	55	60	65	70	75	80	85	90	95	100	105	110	115	120	125	130	135	140	145		
		Heat flow density $\text{W/m}^2$ (spec. heat output $\text{W/m}^2$ )																											
		Avg. surface temp. °C	22.7	23.6	24.5	25.5	26.4	27.3	28.2						29.1	30.0	30.9	31.8	32.7										
20	30	Installation spacing VA mm	150	150	150	75	75																						
		Max. heating circuit area $\text{m}^2$	16	15	13	8	7																						
		Max. heating circuit length m	114	107	94	114	101																						
20	35	Installation spacing VA mm	300	300	225	225	150	150	75	75	75																		
		Max. heating circuit area $\text{m}^2$	33	30	26	22	18	16	11	8	7	5																	
		Max. heating circuit length m	117	107	123	105	127	114	81	114	101	74																	
20	40	Installation spacing VA mm	300	300	300	300	225	225	150	150	150	150	75	75	75	75	75												
		Max. heating circuit area $\text{m}^2$	35	33	28	25	23	21	18	17	15	13	10	8	7	6	5	4											
		Max. heating circuit length m	124	117	101	91	110	101	127	121	107	94	74	114	101	87	74	61											
20	43	Installation spacing VA mm	300	300	300	300	300	225	225	225	150	150	150	15	150	75	75	75	75										
		Max. heating circuit area $\text{m}^2$	35	35	33	30	28	26	24	21	18	16	14	12	10	9	8	7	6	5	3.5								
		Max. heating circuit length m	124	124	117	107	101	123	114	105	127	114	101	87	74	127	114	101	87	74	54								
		Avg. surface temp. °C	26.7	27.6	28.5	29.5	30.4	31.3	32.2						33.1	34.0	34.9												
24	30	Installation spacing VA mm	75																										
		Max. heating circuit area $\text{m}^2$	7																										
		Max. heating circuit length m	101																										
24	35	Installation spacing VA mm		150	150	150	75	75																					
		Max. heating circuit area $\text{m}^2$		13	12	10	8	6.5																					
		Max. heating circuit length m		114	87	74	114	94																					
24	40	Installation spacing VA mm				150	150	150	150	75	75	75																	
		Max. heating circuit area $\text{m}^2$				16	14	12	9	8	7	5																	
		Max. heating circuit length m				114	101	87	67	114	101	74																	
24	43	Installation spacing VA mm					150	150	150	75	75	75	75	75															
		Max. heating circuit area $\text{m}^2$					16	14	12	9	8	7	6	5															
		Max. heating circuit length m					114	101	87	127	114	101	87	74															

Limit curve living area/peripheral zone

Data does not replace precise planning according to DIN EN 1264.

**Presumed marginal conditions:**

Pressure loss: max. 250 mbar  
 Sub insulation R/(U):  $0.75 \text{ m}^2\text{K/W} / (1.33 \text{ W/m}^2\text{K})$

tu: 15 °C  
 Single connection length: 3 - 4 m



# Performance diagrams

Parquet with approx. 22 mm\* or thick carpet\*, heating pipes Ø = 16 mm

Floor covering: **Parquet with approx. 22 mm or thick carpet.** \*Follow manufacturer's specifications.

Surface cover resistance  $R_{\lambda} = 0.15 \text{ m}^2 \text{ K/W}$

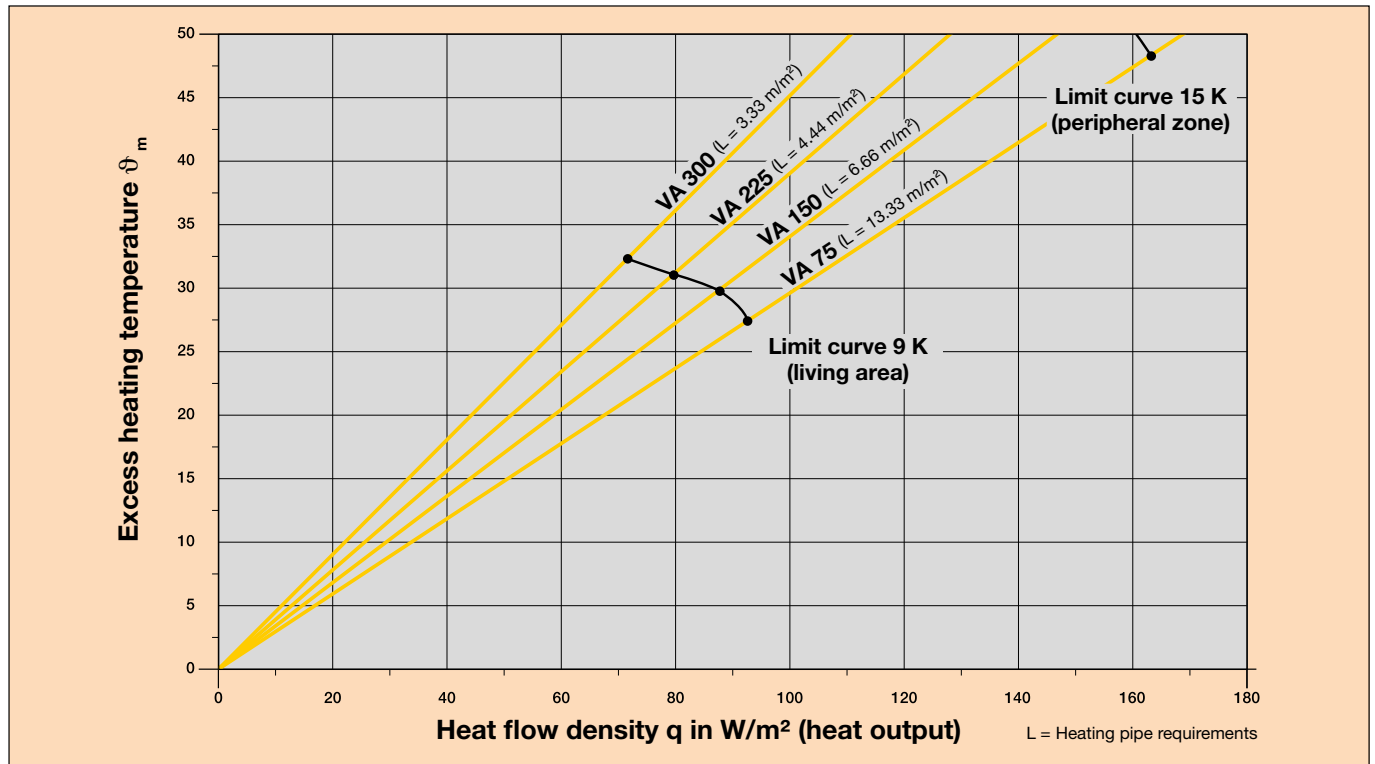

Performance data according to DIN EN 1264

Room temp. °C	Supply temp. °C	Living area														Peripheral zone													
		25	30	35	40	45	50	55	60	65	70	75	80	85	90	95	100	105	110	115	120	125	130	135	140	145			
		Heat flow density W/m² (spec. heat output W/m²)																											
		Avg. surface temp. °C																											
20	30	Installation spacing VA mm	150	75																									
		Max. heating circuit area m²	11	6																									
		Max. heating circuit length m	81	87																									
20	35	Installation spacing VA mm	225	150	150	75	75																						
		Max. heating circuit area m²	24	18	14	8	5																						
		Max. heating circuit length m	114	127	101	114	74																						
20	40	Installation spacing VA mm	300	300	225	150	150	150	75	75																			
		Max. heating circuit area m²	32	28	23	17	14	9	7	5																			
		Max. heating circuit length m	114	101	110	121	101	67	101	74																			
20	43	Installation spacing VA mm	300	300	300	225	225	150	150	75	75	75																	
		Max. heating circuit area m²	34	30	28	24	20	16	12	8	6	4																	
		Max. heating circuit length m	121	107	101	114	96	114	87	114	87	61																	

Limit curve living area/peripheral zone

Data does not replace precise planning according to DIN EN 1264.

**Presumed marginal conditions:**

Pressure loss: max. 250 mbar  
 Sub insulation R/(U): 0.75 m²KW / (1.33 W/m²K)

tu: 15 °C  
 Single connection length: 3 - 4 m



## Cooling output of BEKOTEC-EN 23 F PS

### Notes:

- Average cooling output of 30 - 40 W/m<sup>2</sup> possible with ceramic coverings
- This lets the room temperature be lowered by approx. 3 °C
- Best cooling and heating values with ceramic coverings
- Normal cooling water temperature with approx. 18 °C.
- Ideal for use with heat pumps

The following performance data were determined in W/m<sup>2</sup> based on the installation spacing VA and the temperature difference  $\Delta T$  (room temperature cooling water temperature) according to DIN EN 1264.

### Heating pipe $\varnothing = 16$ mm

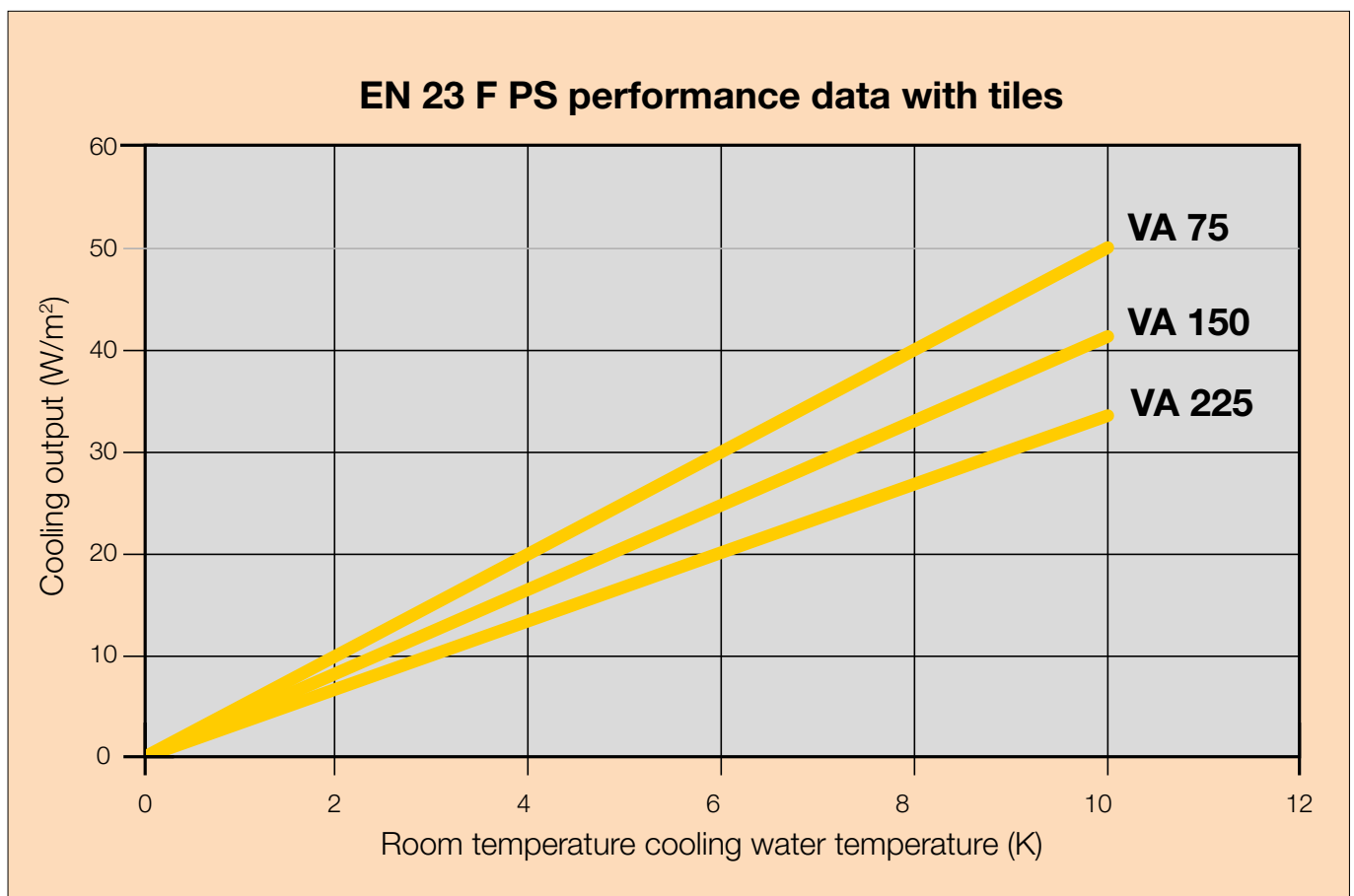

Performance data according to DIN EN 1264





# Performance diagrams

Vinyl, linoleum or parquet up to approx. 8 mm, heating pipes  $\varnothing = 14$  mm

Floor covering: Vinyl, linoleum or parquet up to approx. 8 mm (observe manufacturer recommendations).

Surface cover resistance  $R_{\lambda} = 0.05 \text{ m}^2 \text{ K/W}$

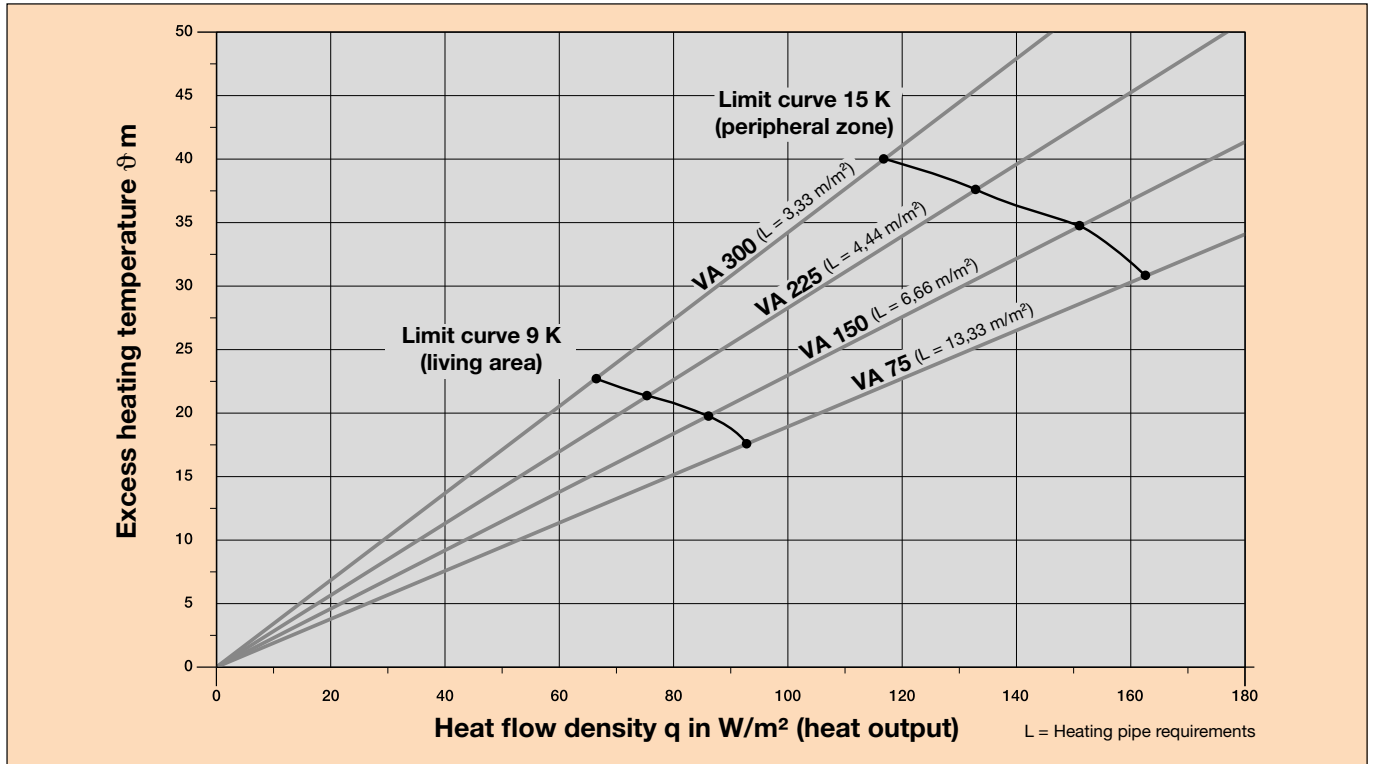

Performance data according to DIN EN 1264

Room temp. °C	Supply temp. °C	Living area														Peripheral zone															
		Heat flow density $q$ in $\text{W/m}^2$ (spec. heat output $\text{W/m}^2$ )																													
		25	30	35	40	45	50	55	60	65	70	75	80	85	90	95	100	105	110	115	120	125	130	135	140	145					
		Avg. surface temp. °C																													
		22.7	23.6	24.5	25.5	26.4	27.3	28.2											29.1	30.0	30.9	31.8	32.7								
20	30	Installation spacing VA mm	150	150	150	75	75																								
		Max. heating circuit area m <sup>2</sup>	13	12	8	6	4.5																								
		Max. heating circuit length m	94	87	61	87	67																								
20	35	Installation spacing VA mm	300	225	225	225	150	150	75	75	75	75																			
		Max. heating circuit area m <sup>2</sup>	26	24	20	18	14	11	8	7	6	3.5																			
		Max. heating circuit length m	94	114	96	87	101	81	114	101	87	54																			
20	40	Installation spacing VA mm	300	300	300	225	225	225	150	150	150	150	75	75	75	75	75														
		Max. heating circuit area m <sup>2</sup>	28	25	24	22	20	17	15	13	11	8	8	7	6	5	3														
		Max. heating circuit length m	101	91	87	105	96	83	107	94	81	61	114	101	87	74	47														
20	43	Installation spacing VA mm	300	300	300	300	225	225	225	150	150	150	150	150	75	75	75	75	75												
		Max. heating circuit area m <sup>2</sup>	30	28	26	24	22	20	18	16	14	13	11	8.5	7.5	7	6	5	4												
		Max. heating circuit length m	107	101	94	87	105	96	87	114	101	94	81	64	107	101	87	74	61												
		Avg. surface temp. °C																													
		26.7	27.6	28.5	29.5	30.4	31.3	32.2											33.1	34.0	34.9										
24	30	Installation spacing VA mm	75																												
		Max. heating circuit area m <sup>2</sup>	6																												
		Max. heating circuit length m	87																												
24	35	Installation spacing VA mm	150	150	75	75	75	75																							
		Max. heating circuit area m <sup>2</sup>	13	10	8	6	4	3																							
		Max. heating circuit length m	94	74	114	87	61	47																							
24	40	Installation spacing VA mm				150	150	150	75	75	75	75																			
		Max. heating circuit area m <sup>2</sup>				13	11	8	7	6	5	3																			
		Max. heating circuit length m				94	81	61	101	87	74	47																			
24	43	Installation spacing VA mm							150	150	150	75	75	75	75	75															
		Max. heating circuit area m <sup>2</sup>								13	11	9	7.5	6.5	5.5	5	3														
		Max. heating circuit length m								94	81	67	107	94	81	74	47														

Limit curve living area/peripheral zone

Data does not replace precise planning according to DIN EN 1264.

**Presumed marginal conditions:**

Pressure loss: max. 250 mbar  
 Sub insulation R/(U): 0.75 m<sup>2</sup>KW / (1.33 W/m<sup>2</sup>K)

tu: 15 °C  
 Single connection length: 3 - 4 m

# Performance diagrams

Carpet up to approx. 8 mm or parquet up to approx. 15 mm, **heating pipes  $\varnothing = 14$  mm**

Floor covering: **Carpet up to approx. 8 mm or parquet up to 15 mm.** \*Observe manufacturer recommendations.

**Surface cover resistance  $R_{\lambda} = 0.10 \text{ m}^2 \text{ K/W}$**

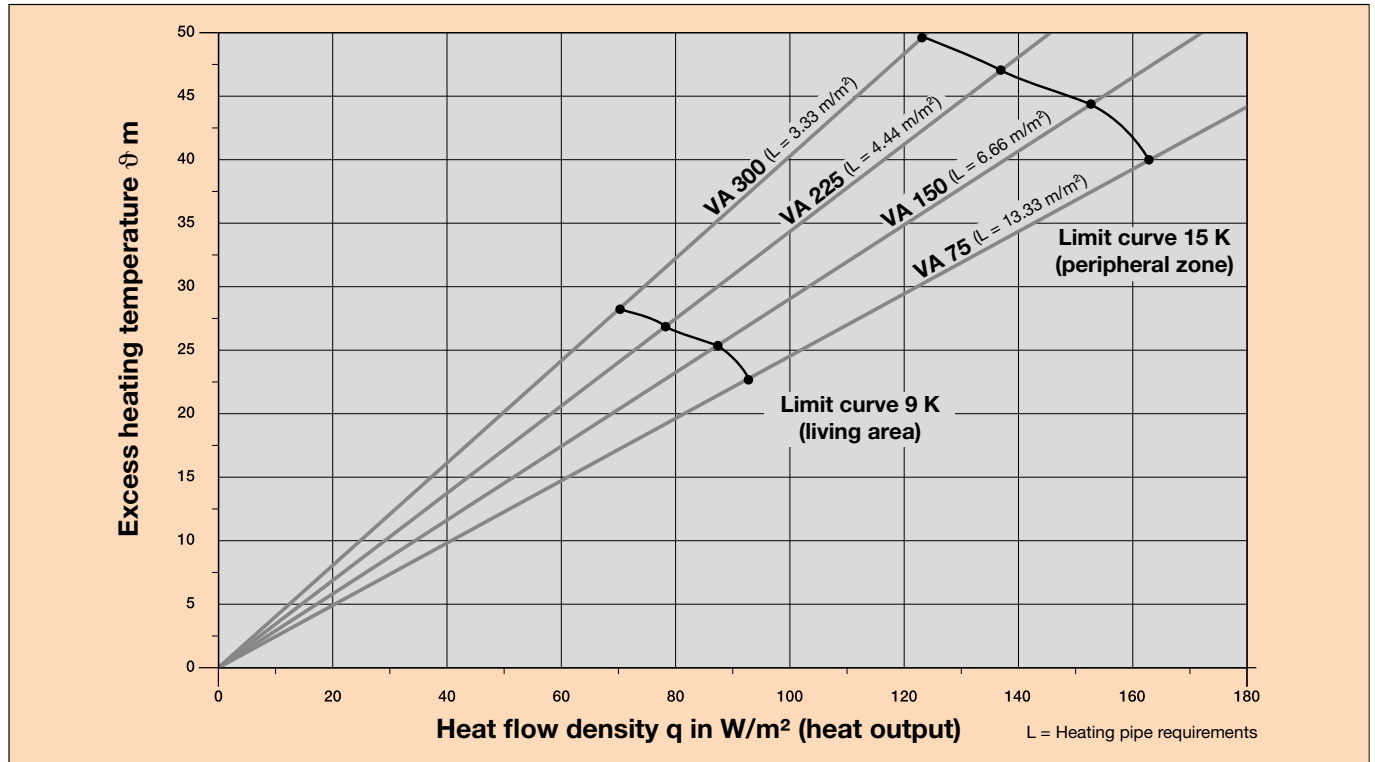

Performance data according to DIN EN 1264

Room temp. °C	Supply temp. °C	Living area															Peripheral zone												
		25	30	35	40	45	50	55	60	65	70	75	80	85	90	95	100	105	110	115	120	125	130	135	140	145			
		Heat flow density $\text{W/m}^2$ (spec. heat output $\text{W/m}^2$ )																											
		Avg. surface temp. °C																											
		22.7	23.6	24.5	25.5	26.4	27.3	28.2																					
20	30	Installation spacing VA mm	150	75	75																								
		Max. heating circuit area $\text{m}^2$	12	7	5																								
		Max. heating circuit length m	87	101	74																								
20	35	Installation spacing VA mm	225	225	150	150	75	75	75																				
		Max. heating circuit area $\text{m}^2$	21	18	15	11	8	6	3																				
		Max. heating circuit length m	101	87	107	81	114	87	47																				
20	40	Installation spacing VA mm	300	300	225	225	150	150	150	75	75	75	75																
		Max. heating circuit area $\text{m}^2$	28	25	22	19	16	13	10	7	6	4.5	3																
		Max. heating circuit length m	101	91	105	92	114	94	74	101	87	67	47																
20	43	Installation spacing VA mm	300	300	300	225	225	150	150	150	75	75	75	75															
		Max. heating circuit area $\text{m}^2$	30	27	24	22	19	16	14	12	8	7	6	4.5	3														
		Max. heating circuit length m	107	97	87	105	92	114	101	87	61	101	87	67	47														

Limit curve living area/peripheral zone

Data does not replace precise planning according to DIN EN 1264.

**Presumed marginal conditions:**

Pressure loss: max. 250 mbar  
Sub insulation  $R/(U)$ :  $0.75 \text{ m}^2\text{K/W} / (1.33 \text{ W/m}^2\text{K})$

$t_u$ : 15 °C  
Single connection length: 3 - 4 m



## Cooling output of BEKOTEC-EN 23 F PS

### Notes:

- Average cooling output of 30 - 40 W/m<sup>2</sup> possible with ceramic coverings
- This lets the room temperature be lowered by approx. 3 °C
- Best cooling and heating values with ceramic coverings
- Normal cooling water temperature with approx. 18 °C.
- Ideal for use with heat pumps

The following performance data were determined in W/m<sup>2</sup> based on the installation spacing VA and the temperature difference  $\Delta T$  (room temperature cooling water temperature) according to DIN EN 1264.

### Heating pipe $\varnothing = 14$ mm

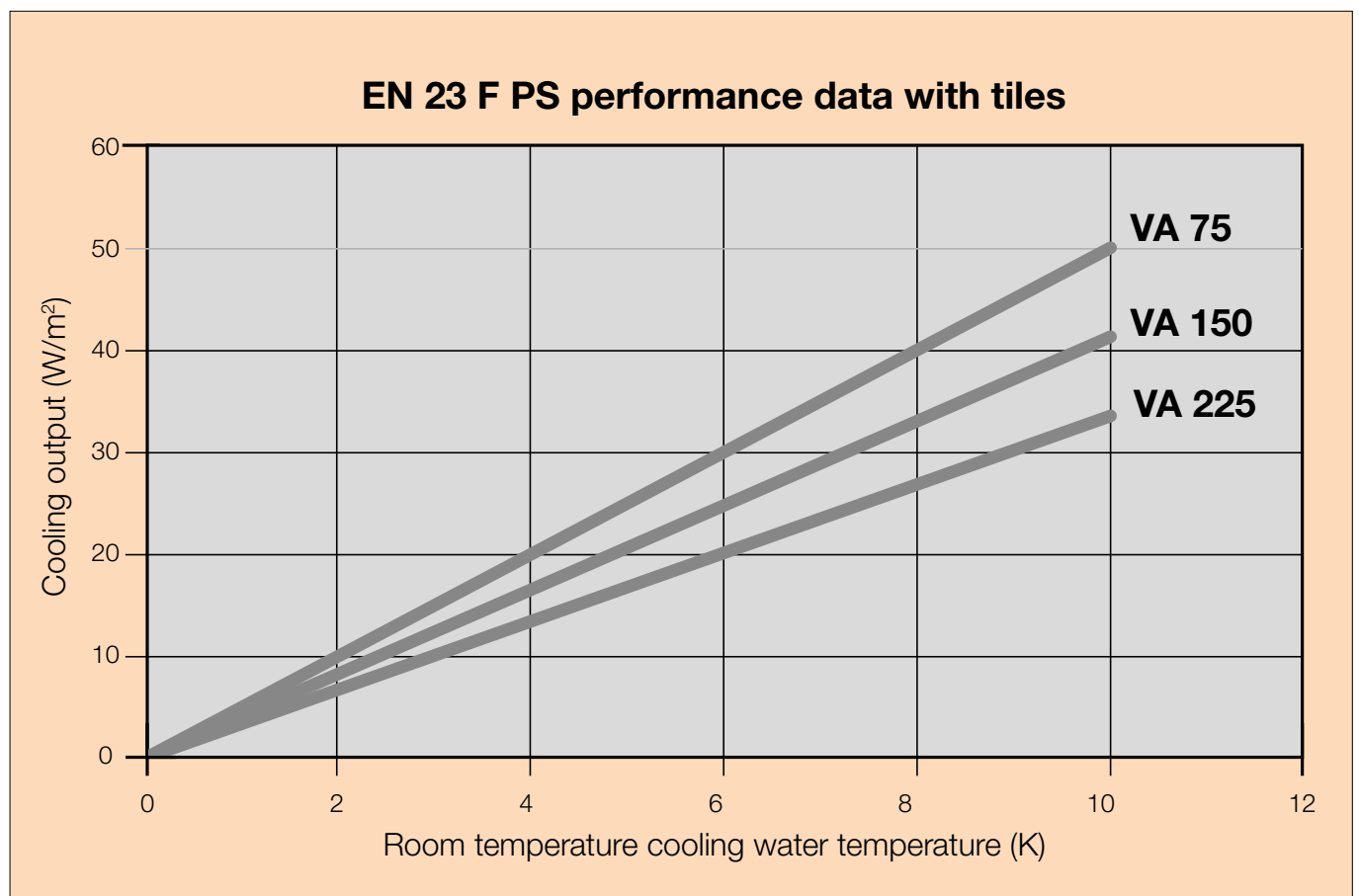

Performance data according to DIN EN 1264



# Schlüter®-BEKOTEC-EN 18 FTS

The quiet type



**BEKOTEC-EN 18 FTS** - suitable for conventional, semi-dry screeds and flowing screeds on cement or gypsum screeds.

## Schlüter-BeKOTEC-EN 18 FTS at a glance

### General product properties

Material studded sheet	Polystyrene (PS) with 70% recycled content with impact sound fleece laminated on the underside
Material thickness	6 mm (of which 5 mm is the fleece)
Panel height	23 mm
Width	1450 mm
Length	850 mm
Weight	2200 g
Working area	1.12 m <sup>2</sup> (1.4 x 0.8 m)

### System data

Weight per unit area with 8 mm coverage	52 kg/m <sup>2</sup>
Screed volume with 8 mm coverage	26 l/m <sup>2</sup>
Traffic load	up to 5 kN/m <sup>2</sup>
System heating pipes	Ø 12 mm red
Heating pipe installation spacing	50/100/150/200/250/300 mm

### Technical properties

Density (structured polystyrene)	1.05 g/cm <sup>3</sup>
Resistance to temperature	-30 °C to +70 °C
Thermal conductivity	0.040 W/mK
Thermal resistance (R-value)	0.157 m <sup>2</sup> /W
U value	6.37 W/m <sup>2</sup> K
Dynamic rigidity	22.1 MN/m <sup>3</sup>
Improvement in sound insulation acc. to DIN EN ISO 10140-1	up to 25 dB

### Certifications/approvals

VOC (French regulation / EMICODE)	available (A+/EC 1 PLUS)
-----------------------------------	--------------------------

# Screed coverage and maximum traffic loads for various surface coverings

## Ceramic coverings

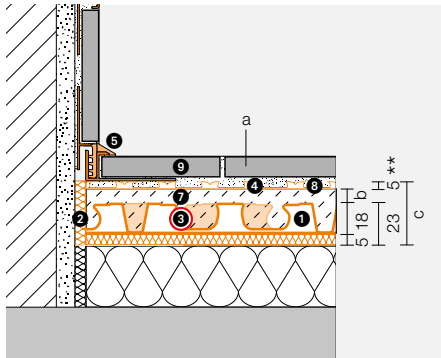

(a) Floor covering	Max. traffic load $q_k$ according to DIN EN 1991	Max. individual load $Q_k$ according to DIN EN 1991	(b) System coverage with conventional screeds	(c) Total thickness of BEKOTEC assembly
Ceramic tile/natural stone	5.0 kN/m <sup>2</sup>	3.5 – 7.0 kN	8 – 20 mm	36 – 48 mm

\*\* Assembly height DITRA = 5 mm, see 4 for additional product specific assembly heights

## Non-ceramic coverings

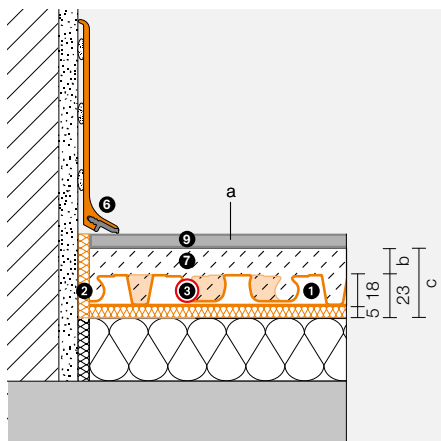

Loose or bonded soft coverings: PVC, vinyl, linoleum, carpet, cork	2 kN/m <sup>2</sup>	2.0 – 3.0 kN	15 – 20 mm	38 – 43 mm
Adhered parquet without tongue and groove connection	5.0 kN/m <sup>2</sup>	3.5 – 7.0 kN	15 – 20 mm	38 – 43 mm
Adhered parquet with tongue and groove connection	5.0 kN/m <sup>2</sup>	3.5 – 7.0 kN	8 – 20 mm	31 – 43 mm
Floating parquet, laminate and coverings with click system	2 kN/m <sup>2</sup>	2.0 – 3.0 kN	8 – 20 mm	31 – 43 mm

## System components

- 1 Schlüter®-BEKOTEC-EN 18 FTS  
Studded screed panel
- 2 Schlüter®-BEKOTEC-BRS 808 KSF  
Edging strip
- 3 Schlüter®-BEKOTEC-THERM-HR  
Heating pipe Ø 12 mm
- 4 Schlüter®-DITRA uncoupling mat  
Schlüter®-DITRA / -DITRA-PS  
(assembly height from 4 mm)  
or  
Schlüter®-DITRA-DRAIN 4  
(assembly height 6 mm)  
or  
Schlüter®-DITRA-HEAT / -DITRA-HEAT-PS  
(assembly height from 6 mm)
- 5 Schlüter®-DILEX -EK or -RF  
Maintenance free edge and movement joint profiles
- 6 Schlüter®-DESIGNBASE-SL, -QD  
Decorative finishing profiles for walls, skirting and floors
- 7 Screed  
based on conventionally applied cement or gypsum screeds  
(see specification on page 32)
- 8 Thin bed tile adhesive
- 9 Ceramic tiles or natural stone
- 10 non-ceramic coverings  
Other coverings (see table) are also feasible in compliance with the applicable installation standards.



# General information on substrates/raw ceilings, preparatory work and insulation layers

## Substrate:

- Load-bearing
- Clean
- Level
- Correct uneven sections in the floor with screeds or suitable bound fill in advance.

**Bound fills:** Bound fills are permitted ( $\geq 100$  kPa)

**Heat insulation:** Additional layers of insulation are permitted.

**Sound insulation:** Not permitted

**If using flowing screeds, installation of a PE separating layer on recommended insulation materials.**

## Edging strips for BEKOTEC-EN 18 FTS

	<b>BRS 810</b> for traditional semi-dry screeds only Height: 100 mm, thickness: 8 mm	<b>BRSK 810</b> for traditional semi-dry screeds only Height: 100 mm, thickness: 8 mm	<b>BRS 808 KF</b> for traditional semi-dry screeds and flowing screeds Height: 80 mm, thickness: 8 mm	<b>BRS 808 KSF</b> for traditional semi-dry screeds and flowing screeds Height: 80 mm, thickness: 8 mm
<b>EN 18 FTS</b>	-	-	-	<b>X</b>

## Installation of the studded screed panel

The installation direction is indicated by the tapered connection studs, which are shown in green colour in the drawing. Cut segments that are longer than > 30 cm can fit into the next row. Remaining areas or cut outs at doors and protrusions and near distributor boxes can be covered with the leveling panel Schlüter-BEKOTEC-ENFGTS. The protruding studded foil must be removed in the edge area of the first row.

**Important:** With flowing screeds, the panel abutting joints must be tightly sealed, e.g. with adhesive tape!

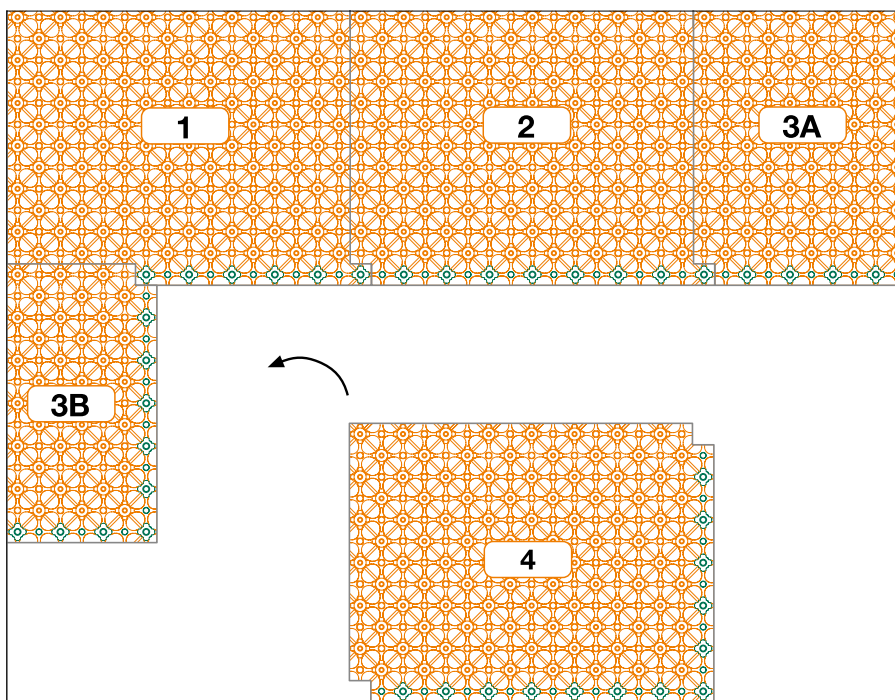

Laying out and fitting the studded screed panel Schlüter-BEKOTEC-EN 18 FTS

Installation process (with optimal use of material)

## Heating pipe installation

The system heating pipes ( $\varnothing$  12 mm) are installed at double the installation spacing to the reversal loop. After the reversal point, insert the return line (blue) into the centre of the remaining space.

**Important:** Form the heating pipes as shown in the drawing!

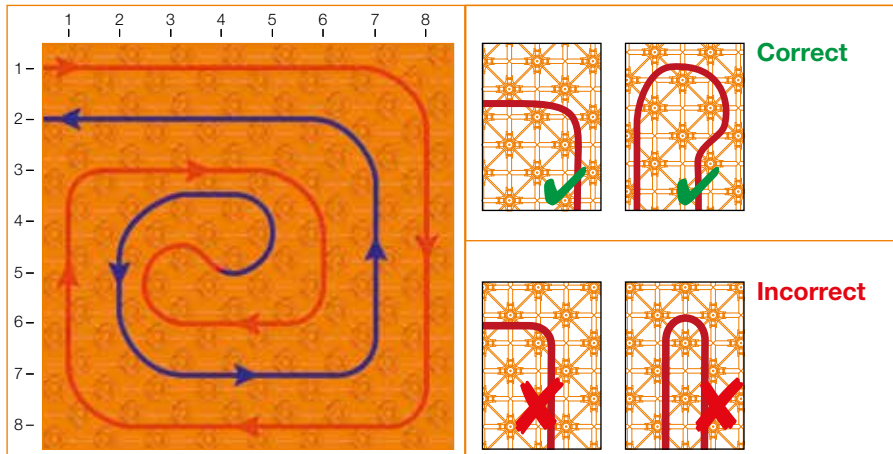

The spacing of the pipes must be determined on the basis of the required heating output and cooling output (see pages 88 - 92).

**Important:** Before and during the installation of the screed, the studded panel may need to be protected from mechanical damage with suitable measures, such as laying out wooden boards.

## Levelling panel

The levelling panel Schlüter-BEKOTEC-ENFGTS is installed in the area of the heating circuit distributors and at thresholds to simplify connections and to minimise cutting waste. It consists of a smooth polystyrene foil material with sound insulation on the reverse side and is adhered below the studded panels, using the supplied double sided adhesive tape.

### Technical data

**Dimensions:** 1400 x 800 mm

**Thickness:** 6.2 mm

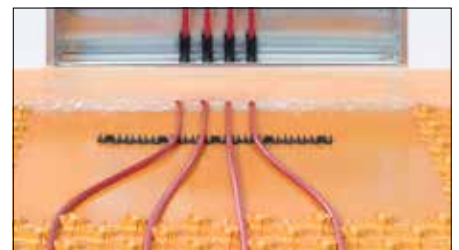



# Performance diagrams

Ceramic thermal comfort floor, heating pipes  $\varnothing = 12 \text{ mm}$

Floor covering: **ceramic tile, natural stone, cast stone** incl. Schlüter-DITRA mat.

Surface cover resistance  $R_{\lambda} = 0.00 \text{ m}^2 \text{ K/W}$

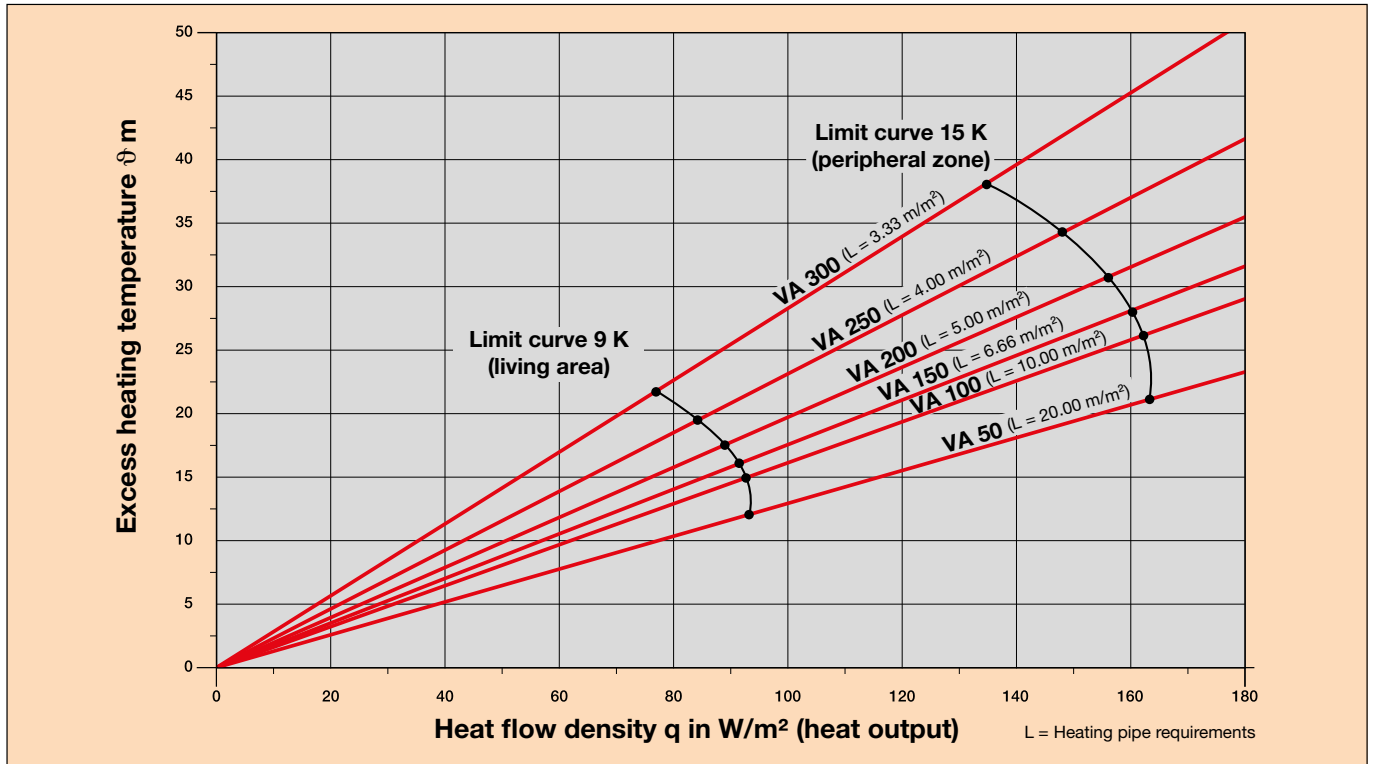

Performance data according to DIN EN 1264

Room temp. °C	Supply temp. °C		Living area													Peripheral zone												
			25	30	35	40	45	50	55	60	65	70	75	80	85	90	95	100	105	110	115	120	125	130	135	140	145	
		Heat flow density $\text{W/m}^2$ (spec. heat output $\text{W/m}^2$ )																										
		Avg. surface temp. °C																										
20	30	Installation spacing VA mm	250	200	200	150	150	100	100	50	50	50																
		Max. heating circuit area $\text{m}^2$	17	15	12	10	8	6	5.5	4	3.5	3																
		Max. heating circuit length m	75	82	67	74	61	67	62	87	77	67																
20	35	Installation spacing VA mm	250	250	250	200	200	150	150	150	150	100	100	100	100	50	50	50	50									
		Max. heating circuit area $\text{m}^2$	21	19	18	16	14	12	11	10	8	7	7	6	5	4	4	3.5	3	2.5								
		Max. heating circuit length m	91	84	80	87	77	87	81	74	61	54	77	67	57	47	87	77	67	57								
20	40	Installation spacing VA mm	300	300	250	250	200	200	150	150	150	150	150	100	100	100	100	100	100	100	50	50	50	50	50	50		
		Max. heating circuit area $\text{m}^2$	25	22	20	19	17	15	14	13	12	11	10	9	8	7	6.5	6	5.5	5	4.5	4	4	3.5	3	2.5		
		Max. heating circuit length m	91	81	87	83	92	82	101	94	87	81	74	67	87	77	72	67	62	57	52	47	87	77	67	57		
20	43	Installation spacing VA mm	300	300	300	300	250	250	200	150	150	150	150	150	150	100	100	100	100	100	100	100	100	50	50			
		Max. heating circuit area $\text{m}^2$	26	24	22	20	19	18	16	14	13	12	11	10.5	10	9	8	7	6.5	6	5.5	5	4.5	4	3.5	3		
		Max. heating circuit length m	93	87	81	74	83	80	87	100	94	87	81	77	74	67	87	77	72	67	67	62	57	52	47	77		
		Avg. surface temp. °C																										
24	30	Installation spacing VA mm	100	100	100	50	50																					
		Max. heating circuit area $\text{m}^2$	5	4.5	3	3	2																					
		Max. heating circuit length m	57	52	37	67	47																					
24	35	Installation spacing VA mm				150	150	150	100	100	100	50	50	50														
		Max. heating circuit area $\text{m}^2$				9	8	7	6	5	4	3.5	3	2.5														
		Max. heating circuit length m				67	61	54	67	57	47	77	67	57														
24	40	Installation spacing VA mm				150	150	150	150	150	150	150	100	100	100	100	50	50	50	50								
		Max. heating circuit area $\text{m}^2$				12	11	10	9	8	7	6	6	5	4.5	4	4	3.5	3	2.5								
		Max. heating circuit length m				87	81	74	67	61	54	47	67	57	52	47	87	77	67	57								
24	43	Installation spacing VA mm							150	150	150	150	150	150	100	100	100	100	50	50	50							
		Max. heating circuit area $\text{m}^2$							12	11.5	11	10	9	8	7	6	5	4.5	4	4	3.5	3						
		Max. heating circuit length m							87	84	81	74	67	61	54	77	67	57	47	87	77	67						

Limit curve living area/peripheral zone

Data does not replace precise planning according to DIN EN 1264.

Presumed marginal conditions:

Pressure loss: max. 250 mbar  
Sub insulation R/(U):  $0.75 \text{ m}^2\text{K/W} / (1.33 \text{ W/m}^2\text{K})$

tu: 15 °C  
Single connection length: 3 - 4 m

# Product service and planning materials

Vinyl, linoleum or parquet up to approx. 8 mm, heating pipes Ø = 12 mm

Floor covering: Vinyl, linoleum or parquet up to approx. 8 mm (observe manufacturer recommendations).

Surface cover resistance  $R_{\lambda} = 0.05 \text{ m}^2 \text{ K/W}$

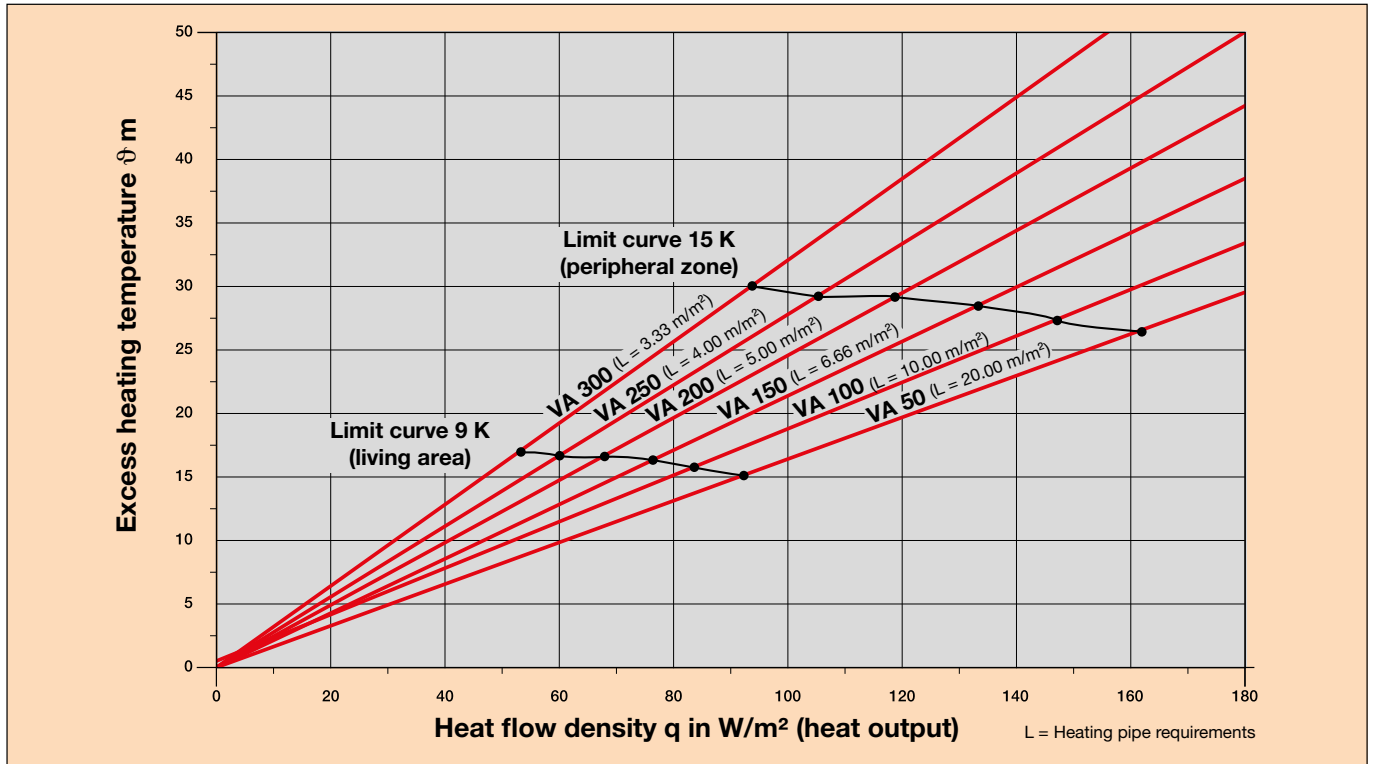

Performance data according to DIN EN 1264

Room temp. °C	Supply temp. °C		Living area													Peripheral zone													
			25	30	35	40	45	50	55	60	65	70	75	80	85	90	95	100	105	110	115	120	125	130	135	140	145		
		Heat flow density W/m <sup>2</sup> (spec. heat output W/m <sup>2</sup> )	25	30	35	40	45	50	55	60	65	70	75	80	85	90	95	100	105	110	115	120	125	130	135	140	145		
		Avg. surface temp. °C	22.7	23.6	24.5	25.5	26.4	27.3	28.2									29.1	30.0	30.9	31.8	32.7							
20	30	Installation spacing VA mm	200	150	100	100	50	50																					
		Max. heating circuit area m <sup>2</sup>	12	10	7	5.5	4	3																					
		Max. heating circuit length m	67	74	77	62	87	67																					
20	35	Installation spacing VA mm	250	250	200	200	150	150	100	100	50	50																	
		Max. heating circuit area m <sup>2</sup>	19	18	16	15	10	8.5	7	6	4	3	2.5																
		Max. heating circuit length m	83	79	87	82	74	64	77	67	87	67	57																
20	40	Installation spacing VA mm	300	250	250	200	200	200	150	150	150	150	100	100	100	50	50												
		Max. heating circuit area m <sup>2</sup>	22	19	18	17	15	13	11	10	9	7.5	6	5	4	3.5	3	2.5											
		Max. heating circuit length m	81	83	79	92	82	72	81	74	67	57	67	57	47	77	67	57											
20	43	Installation spacing VA mm	300	300	300	250	250	200	200	150	150	150	150	150	100	100	100	50	50	20									
		Max. heating circuit area m <sup>2</sup>	24	23	22	19	18	16	14	13	12	11	9.5	7.5	6.5	5.5	5	3.5	3.5	3	2.5								
		Max. heating circuit length m	87	84	81	83	79	87	77	94	87	81	71	57	72	62	57	42	77	67	57								
		Avg. surface temp. °C	26.7	27.6	28.5	29.5	30.4	31.3	32.2	33.1	34.0	34.9																	
24	30	Installation spacing VA mm	50	50																									
		Max. heating circuit area m <sup>2</sup>	3.5	3																									
		Max. heating circuit length m	77	67																									
24	35	Installation spacing VA mm	150	150	100	100	50	50																					
		Max. heating circuit area m <sup>2</sup>	9	8	7	5	4	2.5																					
		Max. heating circuit length m	67	61	77	57	87	57																					
24	40	Installation spacing VA mm				150	150	150	100	100	50	50	50																
		Max. heating circuit area m <sup>2</sup>				10	9	7.5	6	5	4	3	2.5																
		Max. heating circuit length m				74	67	57	67	57	87	67	57																
24	43	Installation spacing VA mm					150	150	150	100	100	100	50	50	50														
		Max. heating circuit area m <sup>2</sup>					10	9	8	6	5	4	3.5	3	2.5														
		Max. heating circuit length m					74	67	61	67	57	47	77	67	57														

Limit curve living area/peripheral zone

Data does not replace precise planning according to DIN EN 1264.

**Presumed marginal conditions:**

Pressure loss: max. 250 mbar  
 Sub insulation R/(U): 0.75 m<sup>2</sup>K/W / (1.33 W/m<sup>2</sup>K)

tu: 15 °C  
 Single connection length: 3 - 4 m







## Cooling output of BEKOTEC-EN 18 FTS

### Notes:

- Average cooling output of 30 - 40 W/m<sup>2</sup> possible with ceramic coverings
- This lets the room temperature be lowered by approx. 3 °C
- Best cooling and heating values with ceramic coverings
- Normal cooling water temperature with approx. 18 °C.
- Ideal for use with heat pumps

The following performance data were determined in W/m<sup>2</sup> based on the installation spacing VA and the temperature difference  $\Delta T$  (room temperature cooling water temperature) according to DIN EN 1264.

### Heating pipe $\varnothing = 12$ mm

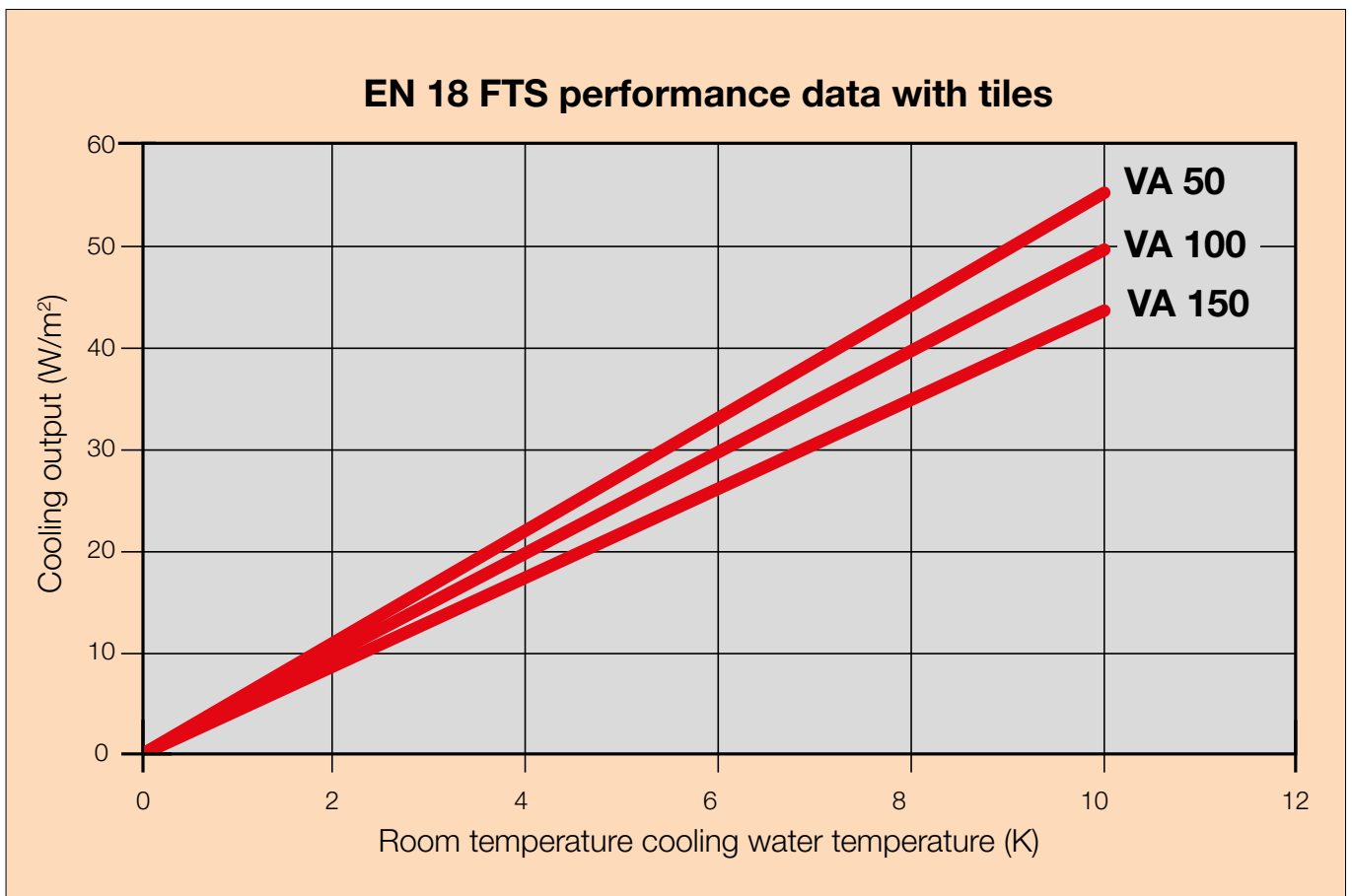

Performance data according to DIN EN 1264

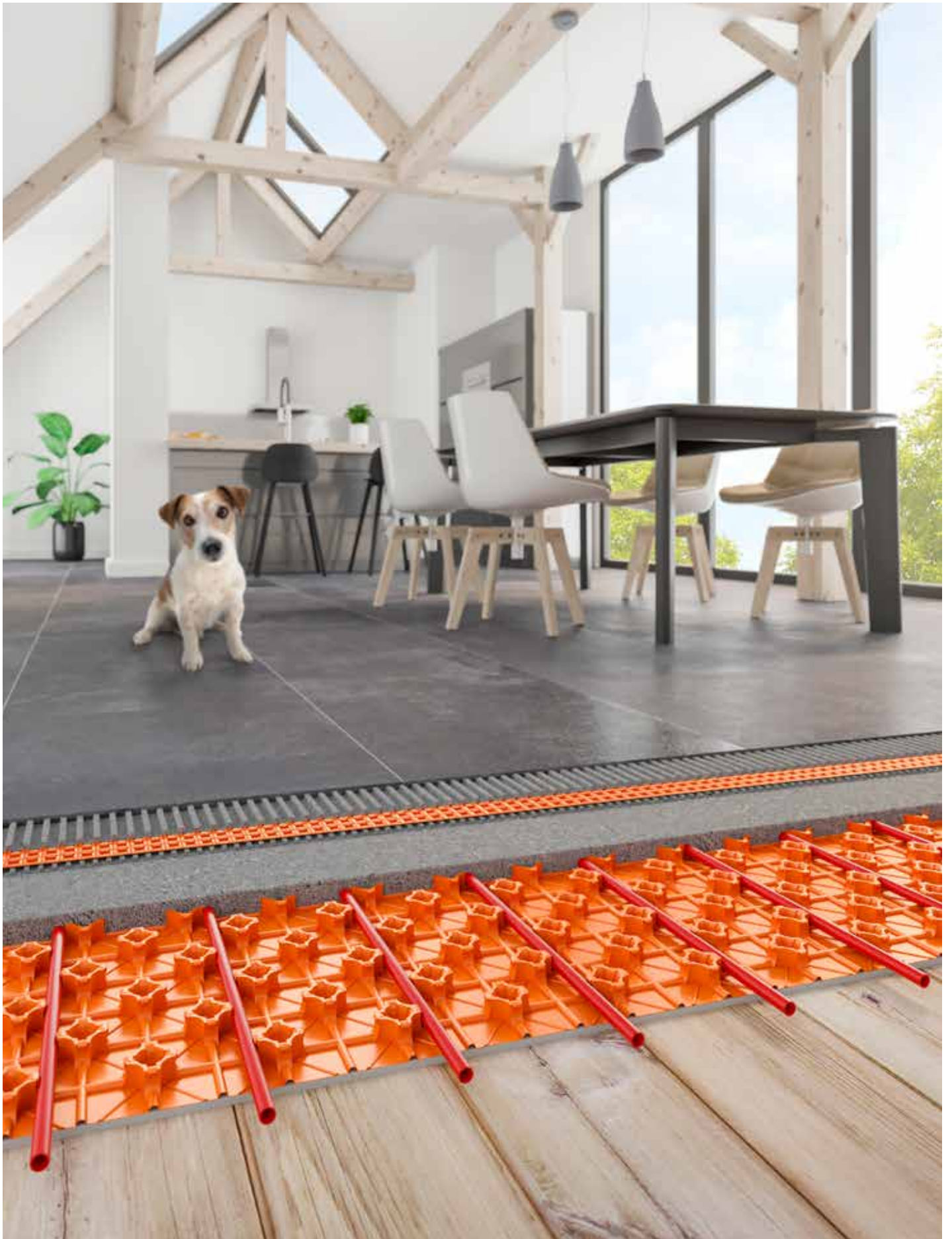

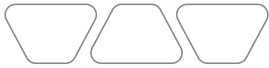

# Schlüter®-BEKOTEC-EN 12 FK

The lightweight type



**BEKOTEC-EN 12 FK** - suitable for conventional, semi-dry screeds and flowing screeds on cement or gypsum screeds.

## Schlüter-BEKOTEC-EN 12 FK at a glance

General product properties	
Material studded sheet	Polystyrene (PS) with 70% recycled content with anchoring fleece on the underside
Material thickness	1 mm
Panel height	12 mm
Width	1150 mm
Length	750 mm
Working area	0.77 m <sup>2</sup> (1.1 x 0.7 m)
System data	
Weight per unit area with 8 mm coverage	40 kg/m <sup>2</sup>
Screed volume with 8 mm coverage	20 l/m <sup>2</sup>
Traffic load	up to 5 kN/m <sup>2</sup>
System heating pipes	diam. 10 mm white
Heating pipe installation spacing	50/100/150/200/250/300 mm
Technical properties	
Density (structured polystyrene)	1.05 g/cm <sup>3</sup>
Resistance to temperature	-30 °C to +70 °C
Certifications/approvals	
VOC (French regulation / EMI CODE)	available (A+/EC 1 PLUS)

# Screed coverage and maximum traffic loads for various surface coverings

## Ceramic coverings

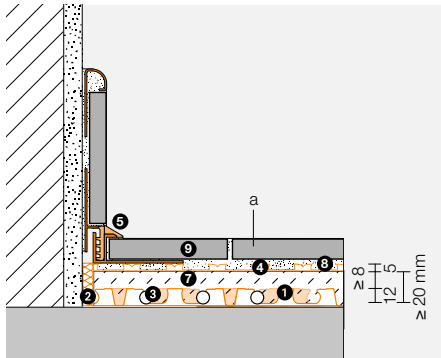

(a) Floor covering	Max. traffic load $q_k$ according to DIN EN 1991	Max. individual load $Q_k$ according to DIN EN 1991	(b) System coverage with conventional screeds	(c) Total thickness of BEKOTEC assembly
Ceramic tile/natural stone	5.0 kN/m <sup>2</sup>	3.5 – 7.0 kN	8 – 15 mm	25 – 32 mm

\*\* Assembly height DITRA = 5 mm, see 4 for additional product specific assembly heights

## Non-ceramic coverings

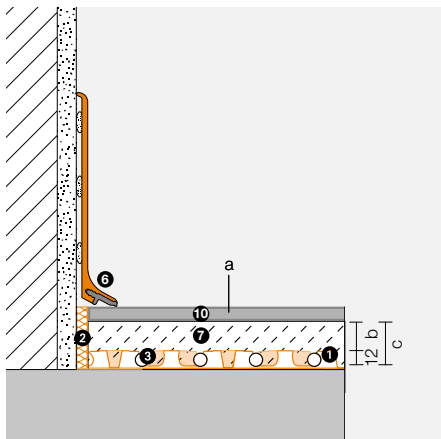

Loose or bonded soft coverings: PVC, vinyl, linoleum, carpet, cork	2 kN/m <sup>2</sup>	2.0 – 3.0 kN	15 mm	27 mm
Adhered parquet without tongue and groove connection	5.0 kN/m <sup>2</sup>	3.5 – 7.0 kN	15 mm	27 mm
Adhered parquet with tongue and groove connection	5.0 kN/m <sup>2</sup>	3.5 – 7.0 kN	8 – 15 mm	20 – 27 mm
Floating parquet, laminate and coverings and coverings with click system	2 kN/m <sup>2</sup>	2.0 – 3.0 kN	8 – 15 mm	20 – 27 mm

## System components

- 1 Schlüter®-BEKOTEC-EN 12 FK  
Studded screed panel  
(directly installed on load bearing substrate only)
- 2 Schlüter®-BEKOTEC-BRS 808 KSF  
Edging strip
- 3 Schlüter®-BEKOTEC-THERM-HR  
Heating pipe Ø 10 mm
- 4 Schlüter®-DITRA uncoupling mat  
Schlüter®-DITRA / -DITRA-PS  
(assembly height from 4 mm)  
or  
Schlüter®-DITRA-DRAIN 4  
(assembly height 6 mm)  
or  
Schlüter®-DITRA-HEAT / -DITRA-HEAT-PS  
(assembly height from 6 mm)
- 5 Schlüter®-DILEX -EK or -RF  
Maintenance free edge and movement joint profiles
- 6 Schlüter®-DESIGNBASE-SL, -QD  
Decorative finishing profiles for walls, skirting and floors
- 7 Screed  
based on conventionally applied cement or gypsum screeds  
(see specification on page 32)
- 8 Thin bed tile adhesive
- 9 Ceramic tiles or natural stone
- 10 non-ceramic coverings  
Other coverings (see table) are also feasible in compliance with the applicable installation standards.

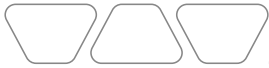

# General information on substrates/raw ceilings, preparatory work and insulation layers

## Substrate:

- Load-bearing
- Clean
- Level
- Correct uneven sections in the floor with screeds or compensating masses in advance.

**Bound fills:** not permissible

**Insulation:** not permissible

## Edging strips for BEKOTEC-EN 12 FK

	<b>BRS 810</b> for traditional semi-dry screeds only Height: 100 mm, thickness: 8 mm	<b>BRSK 810</b> for traditional semi-dry screeds only Height: 100 mm, thickness: 8 mm	<b>BRS 808 KF</b> for traditional semi-dry screeds and flowing screeds Height: 80 mm, thickness: 8 mm	<b>BRS 808 KSF</b> for traditional semi-dry screeds and flowing screeds Height: 80 mm, thickness: 8 mm
<b>EN 12 FK</b>	–	–	–	<b>X</b>

## Installation of the studded screed panel

The installation direction is indicated by the tapered connection studs, which are shown in green colour in the drawing. Cut segments that are longer than  $\geq 30$  cm can fit into the next row. Remaining areas or cut outs at doors and protrusions and near distributor boxes can be covered with the levelling panel Schlüter-BEKOTEC-ENFGK.

Install the studded screed panel as a bonded assembly by adhering the anchoring fleece on the underside to a load bearing and level substrate. Apply thin-bed mortar suitable for the floor on the substrate with a 6 x 6 mm notched trowel.

**Important:** With flowing screeds, the panel abutting joints must be tightly sealed, e.g. with adhesive tape!

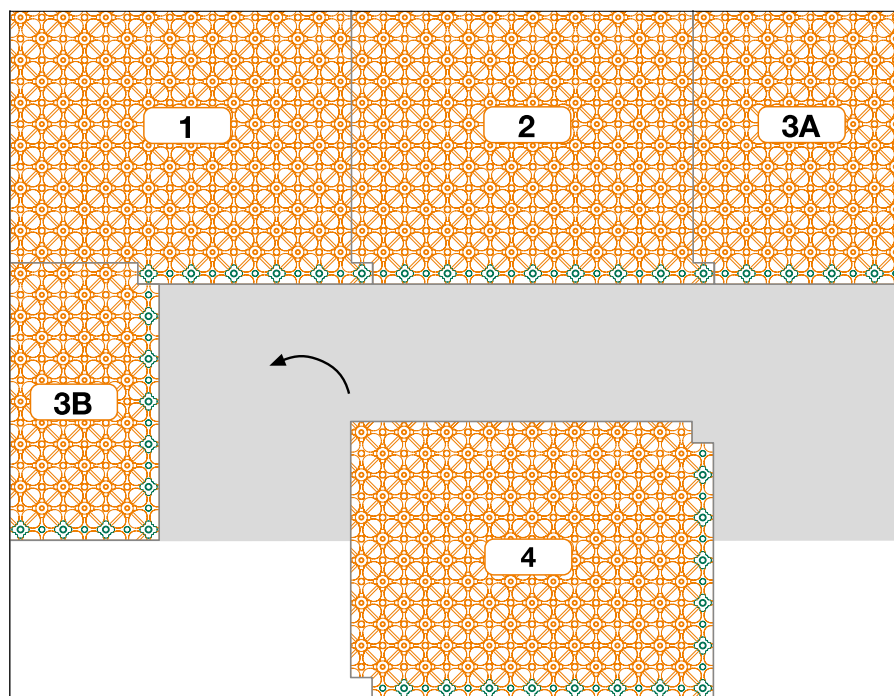

Laying out and fitting the studded screed panel  
Schlüter-BEKOTEC-EN 12 FK

Installation process (with optimal use of material)

## Heating pipe installation

The system heating pipes ( $\varnothing$  10 mm) are installed at double the installation spacing to the reversal loop. After the reversal loop, insert the return line (blue) into the centre of the remaining space

**Important:** Form the heating pipes as shown in the drawing!

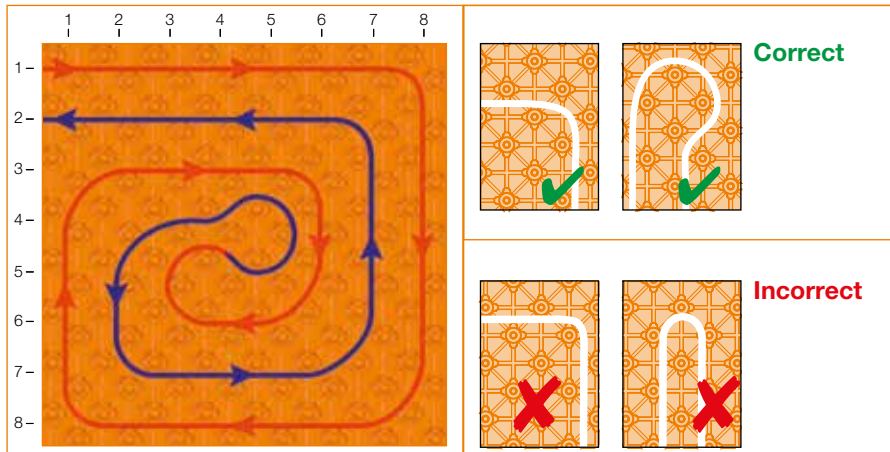

The spacing of the pipes must be determined on the basis of the required heating output and cooling output (see pages 98 - 102).

**Important:** Before and during the installation of the screed, the studded panel may need to be protected from mechanical damage with suitable measures, such as laying out wooden boards.

## Levelling panel

The levelling panel Schlüter-BEKOTEC-ENFGK is directly adhered to the substrate in the area of the heating circuit distributors and at thresholds to simplify connections and to minimise cutting waste.

It consists of smooth polystyrene foil material and is adhered below the studded panels, using the supplied double sided adhesive tape if necessary.

### Technical data

**Dimensions:** 1100 x 700 mm

**Thickness:** 1 mm





# Performance diagram

Ceramic thermal comfort floor, heating pipes  $\varnothing = 10$  mm

Floor covering: ceramic tile, natural stone, cast stone incl. Schlüter-DITRA mat.

Surface cover resistance  $R_{\lambda} = 0.00 \text{ m}^2 \text{ K/W}$

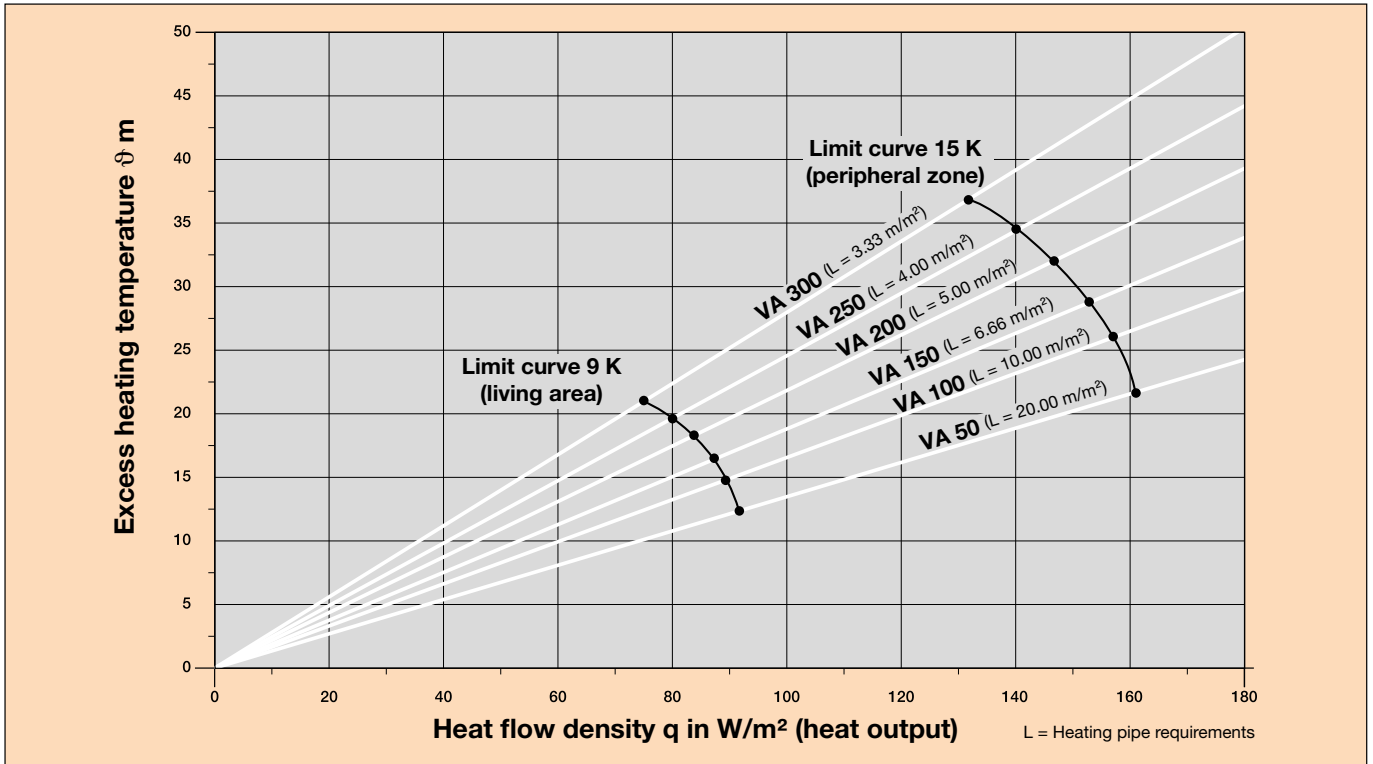

Performance data according to DIN EN 1264

Room temp. °C	Supply temp. °C	Living area													Peripheral zone														
		25	30	35	40	45	50	55	60	65	70	75	80	85	90	95	100	105	110	115	120	125	130	135	140	145			
		Heat flow density W/m <sup>2</sup> (spec. heat output W/m <sup>2</sup> )																											
		Avg. surface temp. °C																											
20	30	Installation spacing VA mm	250	200	200	150	150	100	100	50	50																		
		Max. heating circuit area m <sup>2</sup>	13	11	9	7	6	5	4.5	3.5	3																		
		Max. heating circuit length m	60	62	52	54	47	57	52	77	67																		
20	35	Installation spacing VA mm	250	250	250	200	200	150	150	150	150	100	100	100	100	50	50	50											
		Max. heating circuit area m <sup>2</sup>	19	17	15	13	12	9	8	7	6	5	5	4.5	3.5	3	3.5	2.5	2.5										
		Max. heating circuit length m	83	75	67	72	74	67	61	54	47	41	57	52	42	37	77	57	57										
20	40	Installation spacing VA mm	300	300	250	200	200	200	150	150	150	150	150	100	100	100	100	100	100	100	100	100	50	50	50	50	50	50	50
		Max. heating circuit area m <sup>2</sup>	20	18	17	14	13	12	11	10	9	8.5	8	7.5	7	6	5.5	5	4.5	4	3.5	3	3	3	3	2.5	2	2	2
		Max. heating circuit length m	74	67	75	77	72	67	81	74	67	64	61	57	77	67	62	57	52	47	42	37	67	67	67	67	57	47	47
20	43	Installation spacing VA mm	300	300	300	300	250	250	200	150	150	150	150	150	150	100	100	100	100	100	100	100	100	100	100	100	50	50	
		Max. heating circuit area m <sup>2</sup>	21	20	19	18	17.5	14	13	11	10	9.5	9	8.5	7.5	6.5	6.5	6	6	5.5	5	4.5	4	3.5	3	3	2.5	3	
		Max. heating circuit length m	77	74	71	67	77	63	72	74	74	71	67	64	57	51	72	67	67	62	57	52	47	42	37	42	37	77	67
		Avg. surface temp. °C																											
24	30	Installation spacing VA mm	100	100	100	50	50																						
		Max. heating circuit area m <sup>2</sup>	4.5	4	3	2.5	2																						
		Max. heating circuit length m	52	47	37	57	47																						
24	35	Installation spacing VA mm				150	150	150	100	100	100	50	50																
		Max. heating circuit area m <sup>2</sup>				7	6	5	4.5	4	3	2.5	2																
		Max. heating circuit length m				54	47	41	52	47	37	57	47																
24	40	Installation spacing VA mm				150	150	150	150	150	150	100	100	100	100	50	50	50	50										
		Max. heating circuit area m <sup>2</sup>				10	9.5	9	8	7	6	5	5	4.5	4	3	2.5	2.5	2										
		Max. heating circuit length m				74	71	67	61	54	47	41	57	52	47	67	57	57	47										
24	43	Installation spacing VA mm							150	150	150	150	150	150	100	100	100	100	100	50	50	50							
		Max. heating circuit area m <sup>2</sup>							11	10	9.5	8.5	7.5	7	6	5.5	5	4.5	4	3.5	3	2.5	2						
		Max. heating circuit length m							81	74	71	64	57	54	47	62	57	52	47	42	37	47							

Data does not replace precise planning according to DIN EN 1264.

**Presumed marginal conditions:**  
 Pressure loss: max. 250 mbar  
 Sub insulation R/(U): 0.75 m<sup>2</sup>KW / (1.33 W/m<sup>2</sup>K)

tu: 15 °C  
 Single connection length: 3 - 4 m

Limit curve living area/peripheral zone

# Performance diagram

Vinyl, linoleum or parquet up to approx. 8 mm, heating pipes Ø = 10 mm

Floor covering: Vinyl, linoleum or parquet up to approx. 8 mm (observe manufacturer recommendations).

Surface cover resistance  $R_{\lambda} = 0.05 \text{ m}^2 \text{ K/W}$

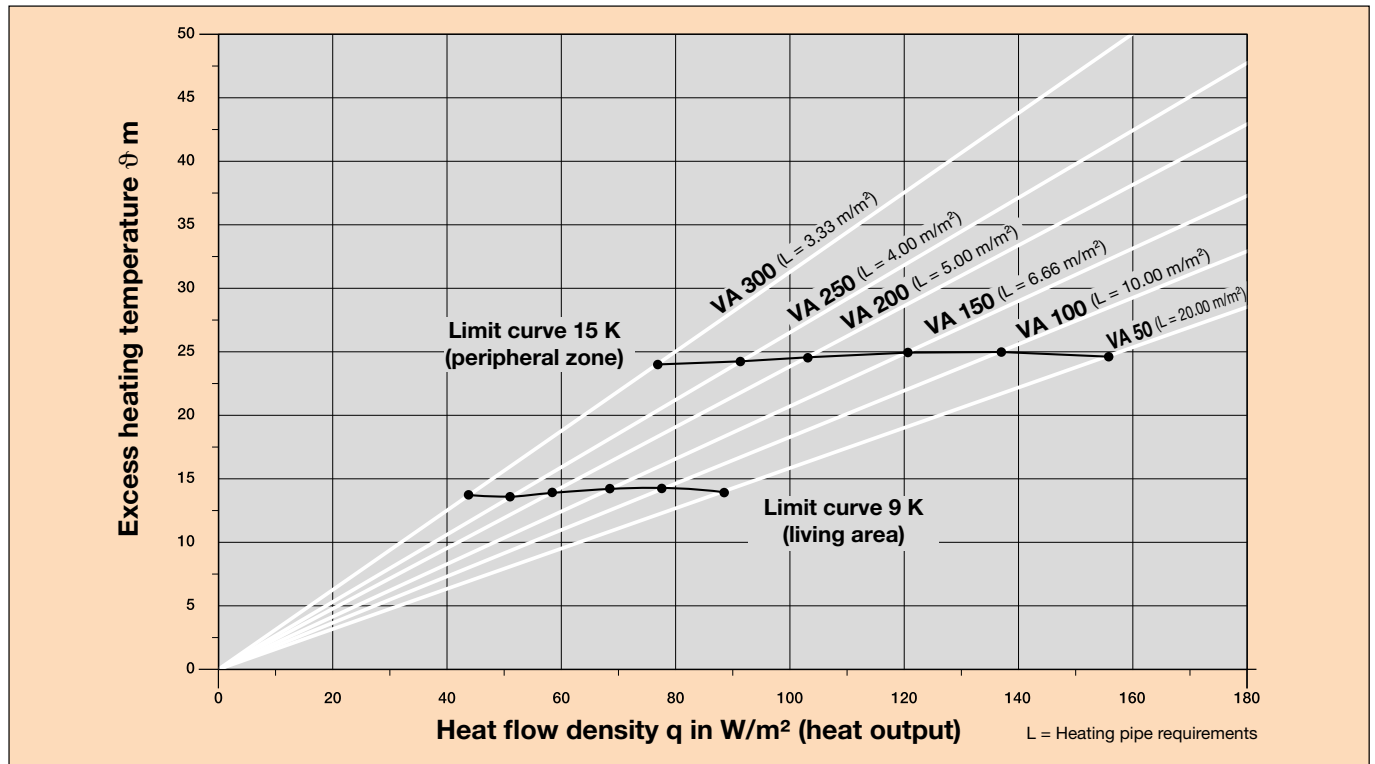

Performance data according to DIN EN 1264

Room temp. °C	Supply temp. °C	Living area																	Peripheral zone									
		25	30	35	40	45	50	55	60	65	70	75	80	85	90	95	100	105	110	115	120	125	130	135	140	145		
Avg. surface temp. °C																												
Avg. surface temp. °C		22.7 23.6 24.5 25.5 26.4 27.3 28.2																	29.1 30.0 30.9 31.8 32.7									
20	30	Installation spacing VA mm	200	150	100	100	50	50																				
		Max. heating circuit area m²	10	8.5	5.5	4	2.5	2																				
		Max. heating circuit length m	57	57	62	47	57	47																				
20	35	Installation spacing VA mm	250	250	200	200	150	150	100	100	50	50																
		Max. heating circuit area m²	16	14	11	9	8	6	5	4	3	2.5	2															
		Max. heating circuit length m	71	63	62	52	61	47	57	47	67	57	47															
20	40	Installation spacing VA mm	300	250	250	200	200	200	150	150	150	150	100	100	100	50	50	50										
		Max. heating circuit area m²	17	15	14	13	12	10	9	8	6.5	5.5	5	4	3	2.5	2	2										
		Max. heating circuit length m	64	67	63	72	67	57	67	61	51	44	57	47	37	57	47	47										
20	43	Installation spacing VA mm	300	300	300	250	250	200	200	150	150	150	150	100	100	100	50	50	50									
		Max. heating circuit area m²	21	20	19	17	15	13	12	10	9	8	7	5.5	5	4.5	3.5	3	2.5	2								
		Max. heating circuit length m	77	74	71	75	67	72	67	74	67	61	54	44	57	52	42	67	57	47								
Avg. surface temp. °C		26.7 27.6 28.5 29.5 30.4 31.3 32.2																	33.1 34.0 34.9									
24	30	Installation spacing VA mm	50																									
		Max. heating circuit area m²	2.5																									
		Max. heating circuit length m	57																									
24	35	Installation spacing VA mm		150	150	100	100	50	50																			
		Max. heating circuit area m²		7	6.5	5	3.5	3	1.5																			
		Max. heating circuit length m		54	51	57	42	67	37																			
24	40	Installation spacing VA mm				150	150	150	100	100	50	50	50															
		Max. heating circuit area m²				8	7	5.5	4.5	3.5	3	2.5	2															
		Max. heating circuit length m				61	54	44	52	42	67	57	47															
24	43	Installation spacing VA mm					150	150	150	100	100	100	50	50	50													
		Max. heating circuit area m²					8	7	5.5	5	4	3.5	3	2.5	2													
		Max. heating circuit length m					61	54	44	57	47	42	67	57	47													

Limit curve living area/peripheral zone

Data does not replace precise planning according to DIN EN 1264.

**Presumed marginal conditions:**  
 Pressure loss: max. 250 mbar  
 Sub insulation R/(U): 0.75 m²KW / (1.33 W/m²K)

tu: 15 °C  
 Single connection length: 3 - 4 m



# Performance diagram

Carpet up to approx. 8 mm or parquet up to approx. 15 mm, **heating pipes  $\varnothing = 10$  mm**

Floor covering: **Carpet up to approx. 8 mm or parquet up to 15 mm** (observe manufacturer recommendations).

**Surface cover resistance  $R_{\lambda} = 0.10 \text{ m}^2 \text{ K/W}$**

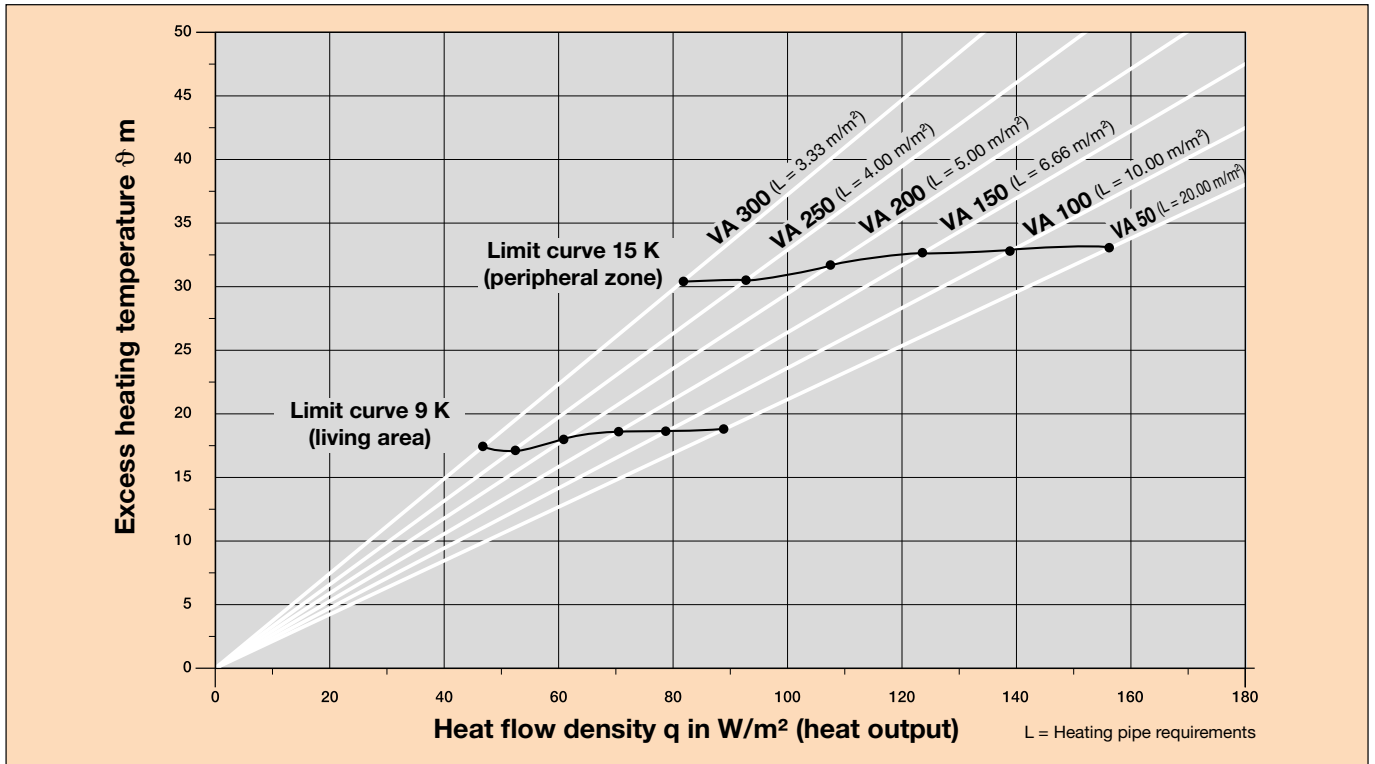

Performance data according to DIN EN 1264

Room temp. °C	Supply temp. °C	Living area																		Peripheral zone									
		Heat flow density $\text{W/m}^2$ (spec. heat output $\text{W/m}^2$ )																											
		25	30	35	40	45	50	55	60	65	70	75	80	85	90	95	100	105	110	115	120	125	130	135	140	145			
		Avg. surface temp. °C																											
		22.7	23.6	24.5	25.5	26.4	27.3	28.2	29.1	30.0	30.9	31.8	32.7																
20	30	Installation spacing VA mm	150	100	50																								
		Max. heating circuit area $\text{m}^2$	7	5	2.5																								
		Max. heating circuit length m	54	57	57																								
20	35	Installation spacing VA mm	250	200	150	150	100	50	50																				
		Max. heating circuit area $\text{m}^2$	14	11	9	6	5	3.5	2.5																				
		Max. heating circuit length m	63	62	67	47	57	77	57																				
20	40	Installation spacing VA mm	300	250	250	200	200	150	150	100	100	50	50																
		Max. heating circuit area $\text{m}^2$	16	15	14	12	9	8	6	5	3.5	3	2																
		Max. heating circuit length m	61	67	63	67	52	61	47	57	42	67	47																
20	43	Installation spacing VA mm	300	300	250	250	200	200	150	150	150	100	100	50	50														
		Max. heating circuit area $\text{m}^2$	21	20	17	15	12	10	9	7	5	5	3.5	3	2.5														
		Max. heating circuit length m	77	74	75	67	67	57	67	54	41	57	42	67	57														

Limit curve living area/peripheral zone

Data does not replace precise planning according to DIN EN 1264.

**Presumed marginal conditions:**  
 Pressure loss: max. 250 mbar  
 Sub insulation R/(U):  $0.75 \text{ m}^2\text{KW} / (1.33 \text{ W/m}^2\text{K})$

tu: 15 °C  
 Single connection length: 3 - 4 m





## Cooling output of BEKOTEC-EN 12 FK

### Notes:

- Average cooling output of 30 - 40 W/m<sup>2</sup> possible with ceramic coverings
- This lets the room temperature be lowered by approx. 3 °C
- Best cooling and heating values with ceramic coverings
- Normal cooling water temperature with approx. 18 °C.
- Ideal for use with heat pumps

The following performance data were determined in W/m<sup>2</sup> based on the installation spacing VA and the temperature difference  $\Delta T$  (room temperature cooling water temperature) according to DIN EN 1264.

### Heating pipe $\varnothing = 10$ mm

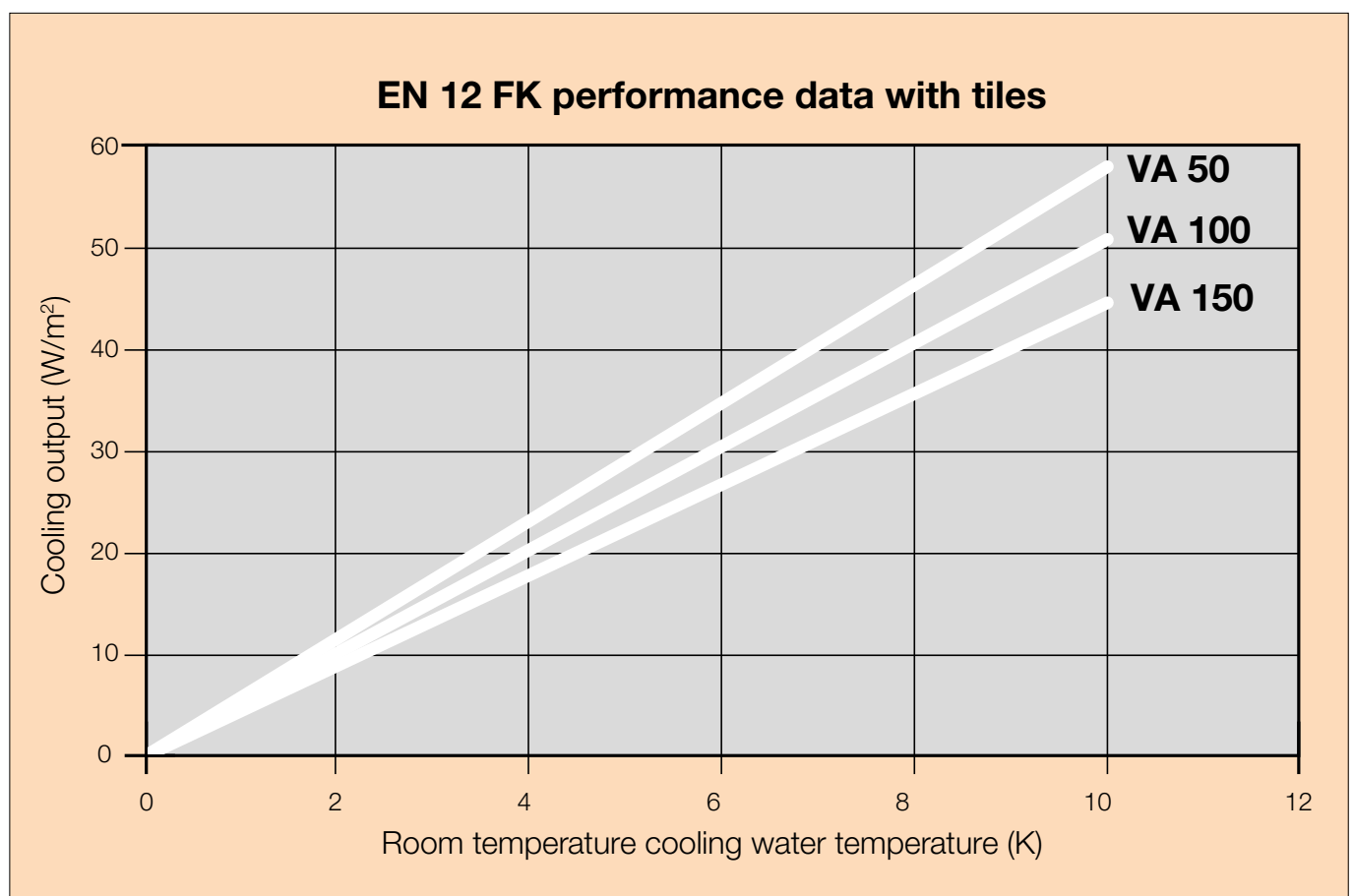

Performance data according to DIN EN 1264





# Schlüter®-BEKOTEC-EN 12 F PS

The fast, lightweight type



**BEKOTEC-EN 12 F PS** - suitable for conventional, semi-dry screeds and flowing screeds on cement or gypsum screeds.

## Schlüter-BEKOTEC-EN 12 F PS at a glance

### General product properties

Material studded sheet	Polystyrene (PS) with 70% recycled content
Adhesive layer	PSA hotmelt
Protective foil	PE, transparent
Material thickness	1 mm
Panel height	12 mm
Width	1150 mm
Length	750 mm
Working area	0.77 m <sup>2</sup> (1.1 x 0.7 m)

### System data

Weight per unit area with 8 mm coverage	40 kg/m <sup>2</sup>
Screed volume with 8 mm coverage	20 l/m <sup>2</sup>
Traffic load	up to 5 kN/m <sup>2</sup>
System heating pipes	diam. 10 mm white
Heating pipe installation spacing	50/100/150/200/250/300 mm

### Technical properties

Density (structured polystyrene)	1.05 g/cm <sup>3</sup>
Resistance to temperature	-30 °C to +70 °C

### Certifications/approvals

VOC (French regulation / EMI CODE)	available (A+/EC 1 PLUS)
------------------------------------	--------------------------

# Screed coverage and maximum traffic loads for various surface coverings

## Ceramic coverings

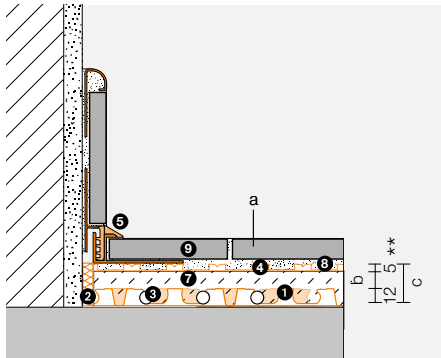

(a) Floor covering	Max. traffic load $q_k$ according to DIN EN 1991	Max. individual load $Q_k$ according to DIN EN 1991	(b) System coverage with conventional screeds	(c) Total thickness of BEKOTEC assembly
Ceramic tile/ natural stone	5.0 kN/m <sup>2</sup>	3.5 – 7.0 kN	8 – 15 mm	25 – 32 mm

\*\* Assembly height DITRA = 5 mm, see 4 for additional product specific assembly heights

## Non-ceramic coverings

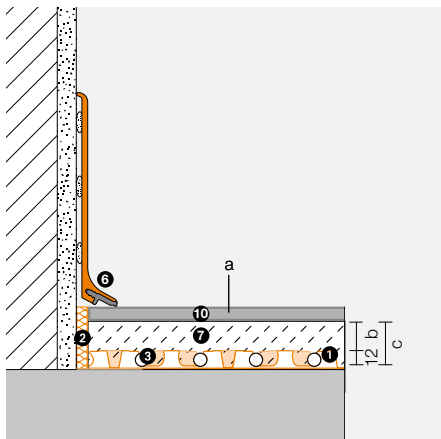

Loose or bonded soft coverings: PVC, vinyl, linoleum, carpet, cork	2 kN/m <sup>2</sup>	2.0 – 3.0 kN	15 mm	27 mm
Adhered parquet without tongue and groove connection	5.0 kN/m <sup>2</sup>	3.5 – 7.0 kN	15 mm	27 mm
Adhered parquet with tongue and groove connection	5.0 kN/m <sup>2</sup>	3.5 – 7.0 kN	8 – 15 mm	20 – 27 mm
Floating parquet, laminate and coverings and coverings with click system	2 kN/m <sup>2</sup>	2.0 – 3.0 kN	8 – 15 mm	20 – 27 mm

## System components

- 1 Schlüter®-BEKOTEC-EN 12 F PS  
Studded screed panel  
(directly installed on load bearing substrate only)
- 2 Schlüter®-BEKOTEC-BRS 808 KSF  
Edging strip
- 3 Schlüter®-BEKOTEC-THERM-HR  
Heating pipe Ø 10 mm
- 4 Schlüter®-DITRA uncoupling mat  
Schlüter®-DITRA / -DITRA-PS  
(assembly height from 4 mm)  
or  
Schlüter®-DITRA-DRAIN 4  
(assembly height 6 mm)  
or  
Schlüter®-DITRA-HEAT / -DITRA-PS  
(assembly height from 6 mm)
- 5 Schlüter®-DILEX -EK or -RF  
Maintenance free edge and movement joint profiles
- 6 Schlüter®-DESIGNBASE-SL, -QD  
Decorative finishing profiles for walls, skirting and floors
- 7 Screed  
based on conventionally applied cement or gypsum screeds  
(see specification on page 32)
- 8 Thin bed tile adhesive
- 9 Ceramic tiles or natural stone
- 10 non-ceramic coverings  
Other coverings (see table) are also feasible in compliance with the applicable installation standards.



# General information on substrates/raw ceilings, preparatory work and insulation layers

## Substrate:

- Load-bearing
- Clean
- Level
- Correct uneven sections in the floor with screeds in advance.

**Bound fills:** not permissible

**Insulation:** not permissible

**Important:** Although it is not mandatory to apply a primer, a standard primer without coarse components such as quartz sand may be used if the condition of the substrate necessitates it.

## Edging strips for BEKOTEC-EN 12 F PS

	<b>BRS 810</b> for traditional semi-dry screeds only Height: 100 mm, thickness: 8 mm	<b>BRSK 810</b> for traditional semi-dry screeds only Height: 100 mm, thickness: 8 mm	<b>BRS 808 KF</b> for traditional semi-dry screeds and flowing screeds Height: 80 mm, thickness: 8 mm	<b>BRS 808 KSF</b> for traditional semi-dry screeds and flowing screeds Height: 80 mm, thickness: 8 mm
<b>EN 12 FK</b>	–	–	–	<b>X</b>

## Installation of the studded screed panel

The installation direction is indicated by the tapered connection studs, which are shown in green colour in the drawing. Cut segments that are longer than  $\geq 30$  cm can fit into the next row. Remaining areas or cut outs at doors and protrusions and near distributor boxes can be covered with the leveling panel Schlüter-BEKOTEC-ENFGK PS.

**Install the studded screed panel as a bonded assembly by firmly adhering it the load bearing and level substrate on the underside.**

**Important:** When installing a flowing screed, carefully place the studded panels and seal the abutting edges/end points.

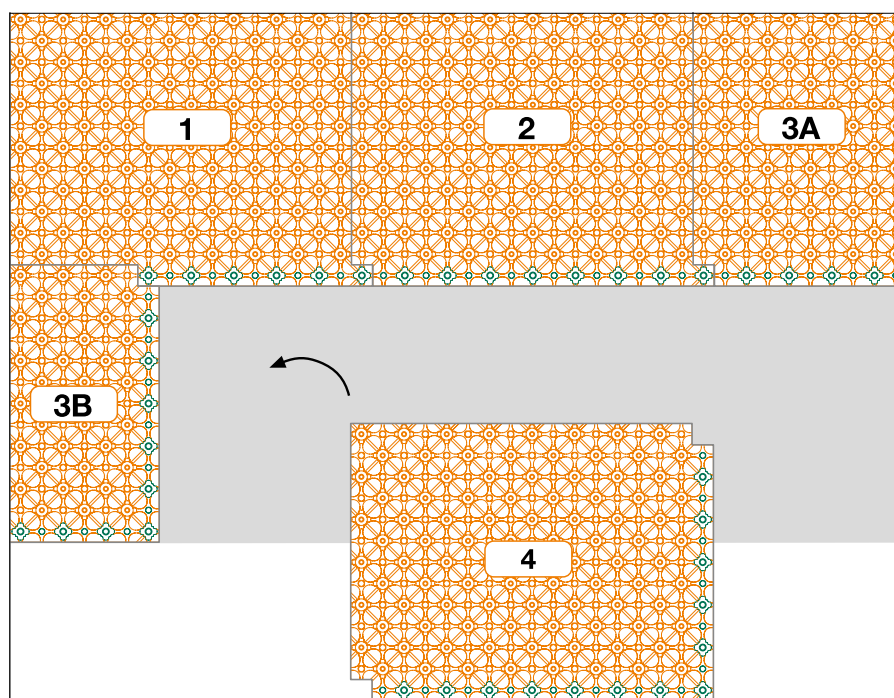

Laying out and fitting the studded screed panel  
Schlüter-BEKOTEC-EN 12 F PS

Installation process (with optimal use of material)

## Heating pipe installation

The system heating pipes ( $\varnothing$  10 mm) are installed at double the installation spacing to the reversal loop. After the reversal loop, insert the return line (blue) into the centre of the remaining space

**Important:** Form the heating pipes as shown in the drawing!

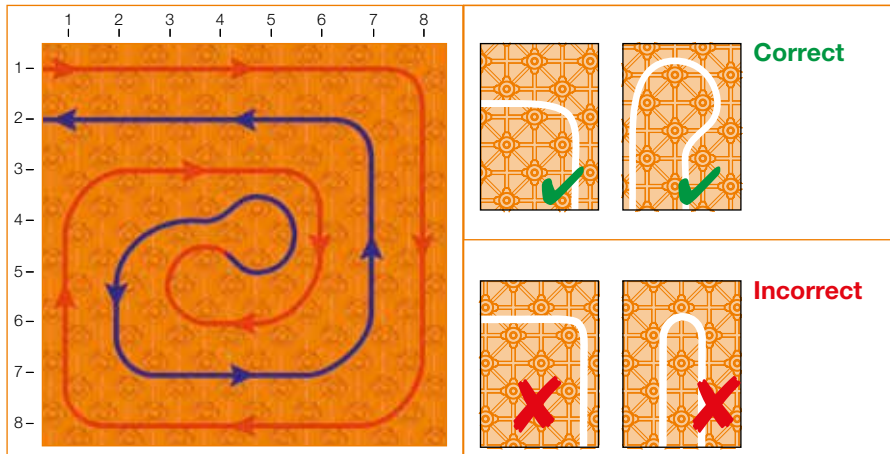

The spacing of the pipes must be determined on the basis of the required heating output and cooling output (see pages 108 - 112).

**Important:** Before and during the installation of the screed, the studded panel may need to be protected from mechanical damage with suitable measures, such as laying out wooden boards.

## Levelling panel

The levelling panel Schlüter-BEKOTEC-ENFGK PS is directly adhered to the substrate in the area of the heating circuit distributors and at thresholds to simplify connections and to minimise cutting waste.

It consists of smooth polystyrene foil material and is adhered below the studded panels, using the supplied double sided adhesive tape if necessary.

### Technical data

**Dimensions:** 1100 x 700 mm

**Thickness:** 1 mm





# Performance diagram

Ceramic thermal comfort floor, heating pipes  $\varnothing = 10 \text{ mm}$

Floor covering: ceramic tile, natural stone, cast stone incl. Schlüter-DITRA mat.

Surface cover resistance  $R_{\lambda} = 0.00 \text{ m}^2 \text{ K/W}$

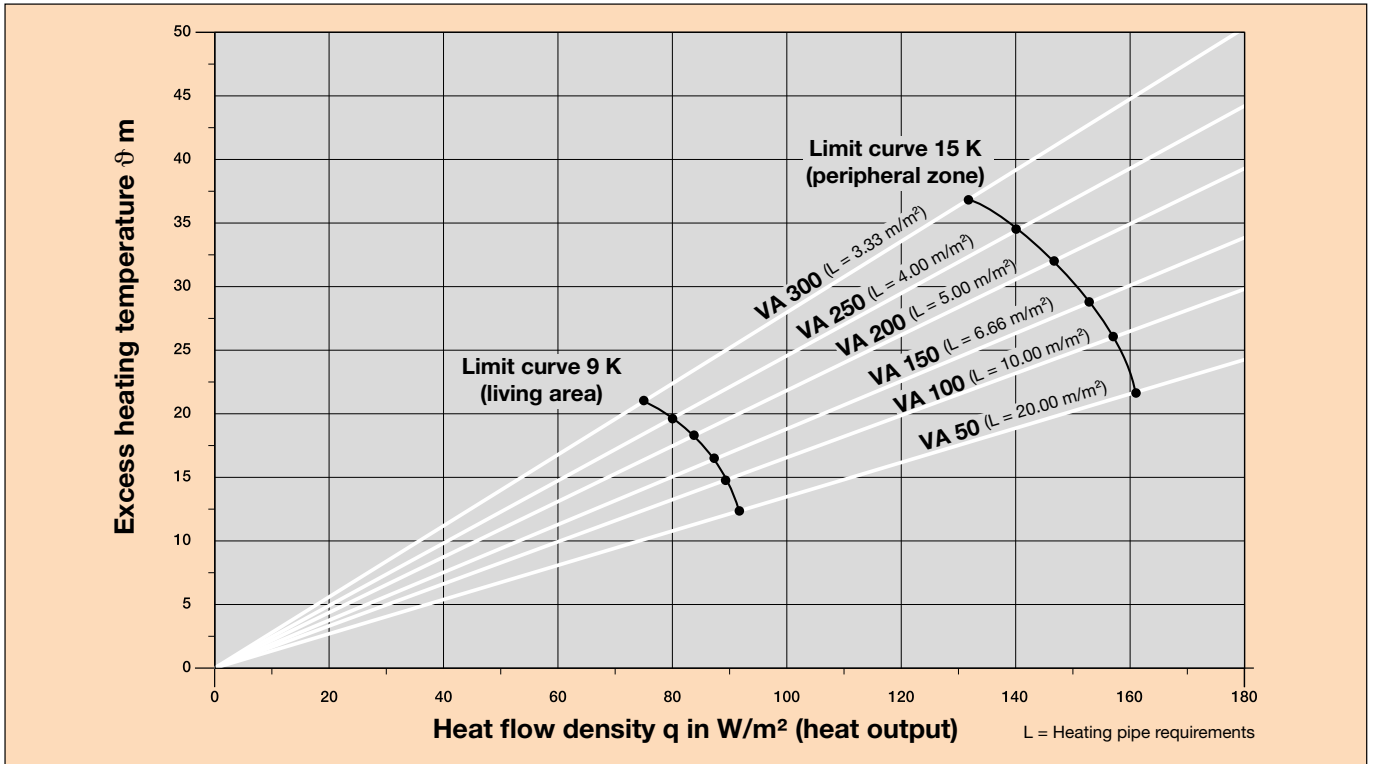

Performance data according to DIN EN 1264

Room temp. °C	Supply temp. °C	Living area													Peripheral zone												
		25	30	35	40	45	50	55	60	65	70	75	80	85	90	95	100	105	110	115	120	125	130	135	140	145	
Avg. surface temp. °C																											
Avg. surface temp. °C		22.7 23.6 24.5 25.5 26.4 27.3 28.2													29.1 30.0 30.9 31.8 32.7												
20	30	Installation spacing VA mm	250	200	200	150	150	100	100	50	50																
		Max. heating circuit area m²	13	11	9	7	6	5	4.5	3.5	3																
		Max. heating circuit length m	60	62	52	54	47	57	52	77	67																
20	35	Installation spacing VA mm	250	250	250	200	200	150	150	150	150	100	100	100	50	50	50										
		Max. heating circuit area m²	19	17	15	13	12	9	8	7	6	5	4.5	3.5	3	3.5	2.5	2.5									
		Max. heating circuit length m	83	75	67	72	74	67	61	54	47	41	57	52	42	37	77	57	57								
20	40	Installation spacing VA mm	300	300	250	200	200	200	150	150	150	150	100	100	100	100	100	100	100	100	100	50	50	50	50	50	50
		Max. heating circuit area m²	20	18	17	14	13	12	11	10	9	8.5	8	7.5	7	6	5.5	5	4.5	4	3.5	3	3	3	2.5	2	2
		Max. heating circuit length m	74	67	75	77	72	67	81	74	67	64	61	57	77	67	62	57	52	47	42	37	67	67	57	47	47
20	43	Installation spacing VA mm	300	300	300	300	250	250	200	150	150	150	150	150	150	100	100	100	100	100	100	100	100	100	50	50	
		Max. heating circuit area m²	21	20	19	18	17.5	14	13	11	10	9.5	9	8.5	7.5	6.5	6.5	6	6	5.5	5	4.5	4	3.5	3	3.5	3
		Max. heating circuit length m	77	74	71	67	77	63	72	74	74	71	67	64	57	51	72	67	67	62	57	52	47	42	37	77	67
Avg. surface temp. °C		26.7 27.6 28.5 29.5 30.4 31.3 32.2													33.1 34.0 34.9												
24	30	Installation spacing VA mm	100	100	100	50	50																				
		Max. heating circuit area m²	4.5	4	3	2.5	2																				
		Max. heating circuit length m	52	47	37	57	47																				
24	35	Installation spacing VA mm				150	150	150	100	100	50	50															
		Max. heating circuit area m²				7	6	5	4.5	4	3	2.5	2														
		Max. heating circuit length m				54	47	41	52	47	37	57	47														
24	40	Installation spacing VA mm					150	150	150	150	150	150	100	100	100	50	50	50	50								
		Max. heating circuit area m²					10	9.5	9	8	7	6	5	5	4.5	4	3	2.5	2.5	2							
		Max. heating circuit length m					74	71	67	61	54	47	41	57	52	47	67	57	57	47							
24	43	Installation spacing VA mm							150	150	150	150	150	150	100	100	100	100	50	50	50						
		Max. heating circuit area m²								11	10	9.5	8.5	7.5	7	6	5.5	5	4.5	4	3.5	3	2.5	2			
		Max. heating circuit length m								81	74	71	64	57	54	47	62	57	52	47	42	37	57	47			

Data does not replace precise planning according to DIN EN 1264.

**Presumed marginal conditions:**  
 Pressure loss: max. 250 mbar  
 Sub insulation R(U): 0.75 m²KW / (1.33 W/m²K)

tu: 15 °C  
 Single connection length: 3 - 4 m

Limit curve living area/peripheral zone

# Performance diagram

Vinyl, linoleum or parquet up to approx. 8 mm, heating pipes Ø = 10 mm

Floor covering: Vinyl, linoleum or parquet up to approx. 8 mm (observe manufacturer recommendations).

Surface cover resistance  $R_{\lambda} = 0.05 \text{ m}^2 \text{ K/W}$

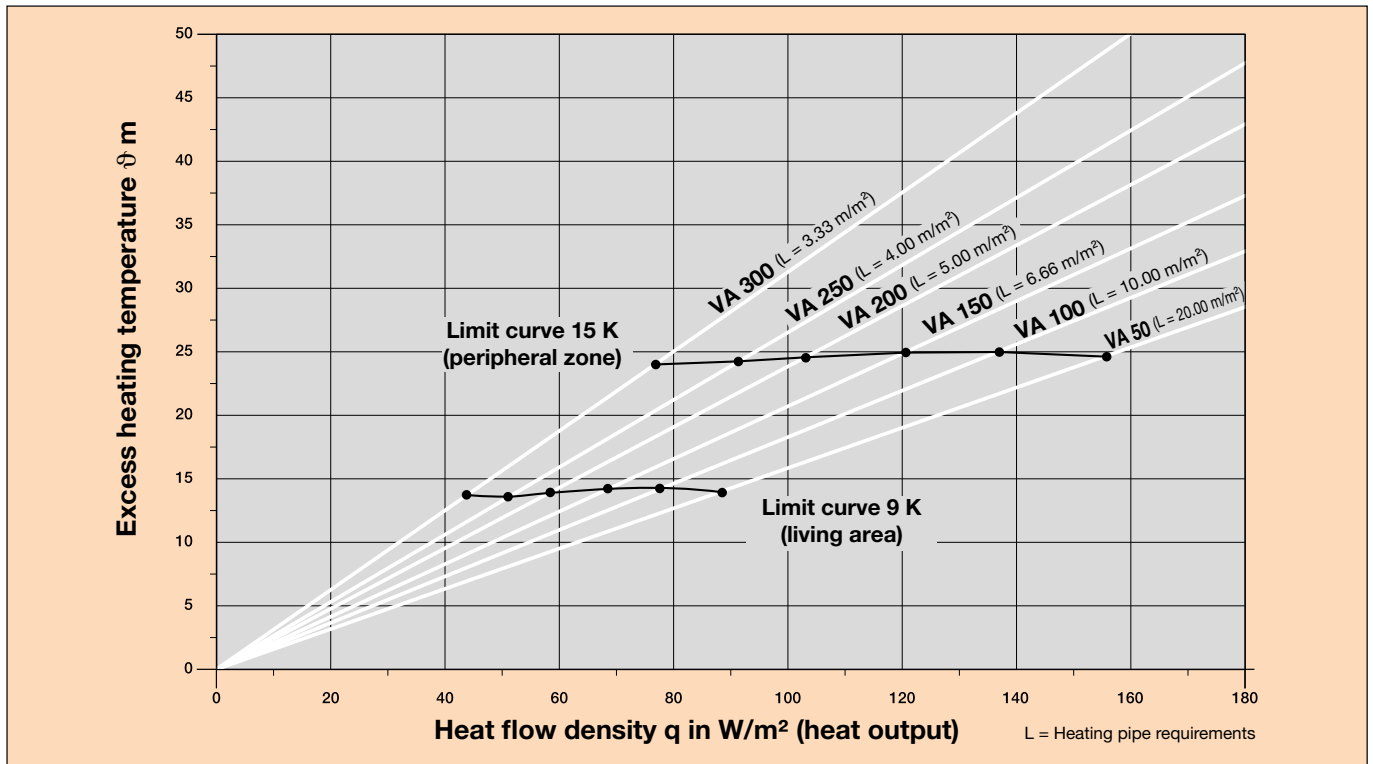

Performance data according to DIN EN 1264

Room temp. °C	Supply temp. °C	Living area																	Peripheral zone									
		25	30	35	40	45	50	55	60	65	70	75	80	85	90	95	100	105	110	115	120	125	130	135	140	145		
Avg. surface temp. °C																												
Avg. surface temp. °C																												
20	30	Installation spacing VA mm	200	150	100	100	50	50																				
		Max. heating circuit area m²	10	8.5	5.5	4	2.5	2																				
		Max. heating circuit length m	57	57	62	47	57	47																				
20	35	Installation spacing VA mm	250	250	200	200	150	150	100	100	50	50																
		Max. heating circuit area m²	16	14	11	9	8	6	5	4	3	2.5	2															
		Max. heating circuit length m	71	63	62	52	61	47	57	47	67	57	47															
20	40	Installation spacing VA mm	300	250	250	200	200	150	150	150	150	100	100	100	50	50	50											
		Max. heating circuit area m²	17	15	14	13	12	10	9	8	6.5	5.5	5	4	3	2.5	2	2										
		Max. heating circuit length m	64	67	63	72	67	57	67	61	51	44	57	47	37	57	47	47										
20	43	Installation spacing VA mm	300	300	300	250	250	200	200	150	150	150	150	100	100	100	50	50	50									
		Max. heating circuit area m²	21	20	19	17	15	13	12	10	9	8	7	5.5	5	4.5	3.5	3	2.5	2								
		Max. heating circuit length m	77	74	71	75	67	72	67	74	67	61	54	44	57	52	42	67	57	47								
Avg. surface temp. °C																												
Avg. surface temp. °C																												
24	30	Installation spacing VA mm	50																									
		Max. heating circuit area m²	2.5																									
		Max. heating circuit length m	57																									
24	35	Installation spacing VA mm		150	150	100	100	50	50																			
		Max. heating circuit area m²		7	6.5	5	3.5	3	1.5																			
		Max. heating circuit length m		54	51	57	42	67	37																			
24	40	Installation spacing VA mm				150	150	150	100	100	50	50	50															
		Max. heating circuit area m²				8	7	5.5	4.5	3.5	3	2.5	2															
		Max. heating circuit length m				61	54	44	52	42	67	57	47															
24	43	Installation spacing VA mm						150	150	150	100	100	100	50	50	50												
		Max. heating circuit area m²						8	7	5.5	5	4	3.5	3	2.5	2												
		Max. heating circuit length m						61	54	44	57	47	42	67	57	47												

Limit curve living area/peripheral zone

Data does not replace precise planning according to DIN EN 1264.

**Presumed marginal conditions:**  
 Pressure loss: max. 250 mbar  
 Sub insulation R/(U): 0.75 m²KW / (1.33 W/m²K)

tu: 15 °C  
 Single connection length: 3 - 4 m



# Performance diagram

Carpet up to approx. 8 mm or parquet up to approx. 15 mm, **heating pipes  $\varnothing = 10$  mm**

Floor covering: **Carpet up to approx. 8 mm or parquet up to 15 mm** (observe manufacturer recommendations).

**Surface cover resistance  $R_{\lambda} = 0.10$  m<sup>2</sup> K/W**

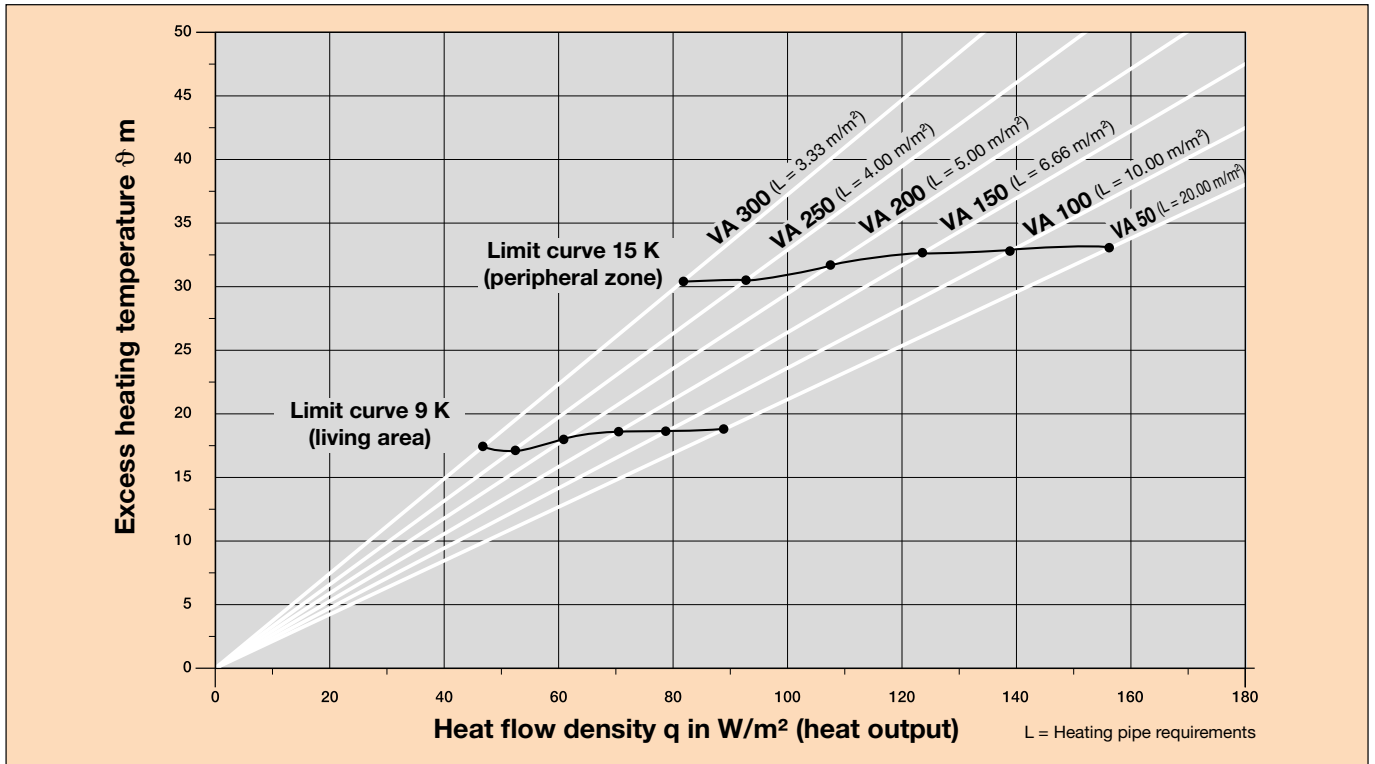

Performance data according to DIN EN 1264

Room temp. °C	Supply temp. °C		Living area																	Peripheral zone									
			25	30	35	40	45	50	55	60	65	70	75	80	85	90	95	100	105	110	115	120	125	130	135	140	145		
		Heat flow density $W/m^2$ (spec. heat output $W/m^2$ )	25	30	35	40	45	50	55	60	65	70	75	80	85	90	95	100	105	110	115	120	125	130	135	140	145		
		Avg. surface temp. °C	22.7	23.6	24.5	25.5	26.4	27.3	28.2	29.1	30.0	30.9	31.8	32.7															
20	30	Installation spacing VA mm	150	100	50																								
		Max. heating circuit area $m^2$	7	5	2.5																								
		Max. heating circuit length m	54	57	57																								
20	35	Installation spacing VA mm	250	200	150	150	100	50	50																				
		Max. heating circuit area $m^2$	14	11	9	6	5	3.5	2.5																				
		Max. heating circuit length m	63	62	67	47	57	77	57																				
20	40	Installation spacing VA mm	300	250	250	200	200	150	150	100	100	50	50																
		Max. heating circuit area $m^2$	16	15	14	12	9	8	6	5	3.5	3	2																
		Max. heating circuit length m	61	67	63	67	52	61	47	57	42	67	47																
20	43	Installation spacing VA mm	300	300	250	250	200	200	150	150	150	100	100	50	50														
		Max. heating circuit area $m^2$	21	20	17	15	12	10	9	7	5	5	3.5	3	2.5														
		Max. heating circuit length m	77	74	75	67	67	57	67	54	41	57	42	67	57														

Limit curve living area/peripheral zone

Data does not replace precise planning according to DIN EN 1264.

**Presumed marginal conditions:**  
 Pressure loss: max. 250 mbar  
 Sub insulation R/(U): 0.75  $m^2K/W$  / (1.33  $W/m^2K$ )

tu: 15 °C  
 Single connection length: 3 - 4 m

# Performance diagram

Parquet with approx. 22 mm or thick carpet, heating pipes  $\varnothing = 10$  mm

Floor covering: **Parquet of approx. 22 mm or thick carpet** (observe manufacturer recommendations).

Surface cover resistance  $R_{\lambda} = 0.15$  m<sup>2</sup> K/W

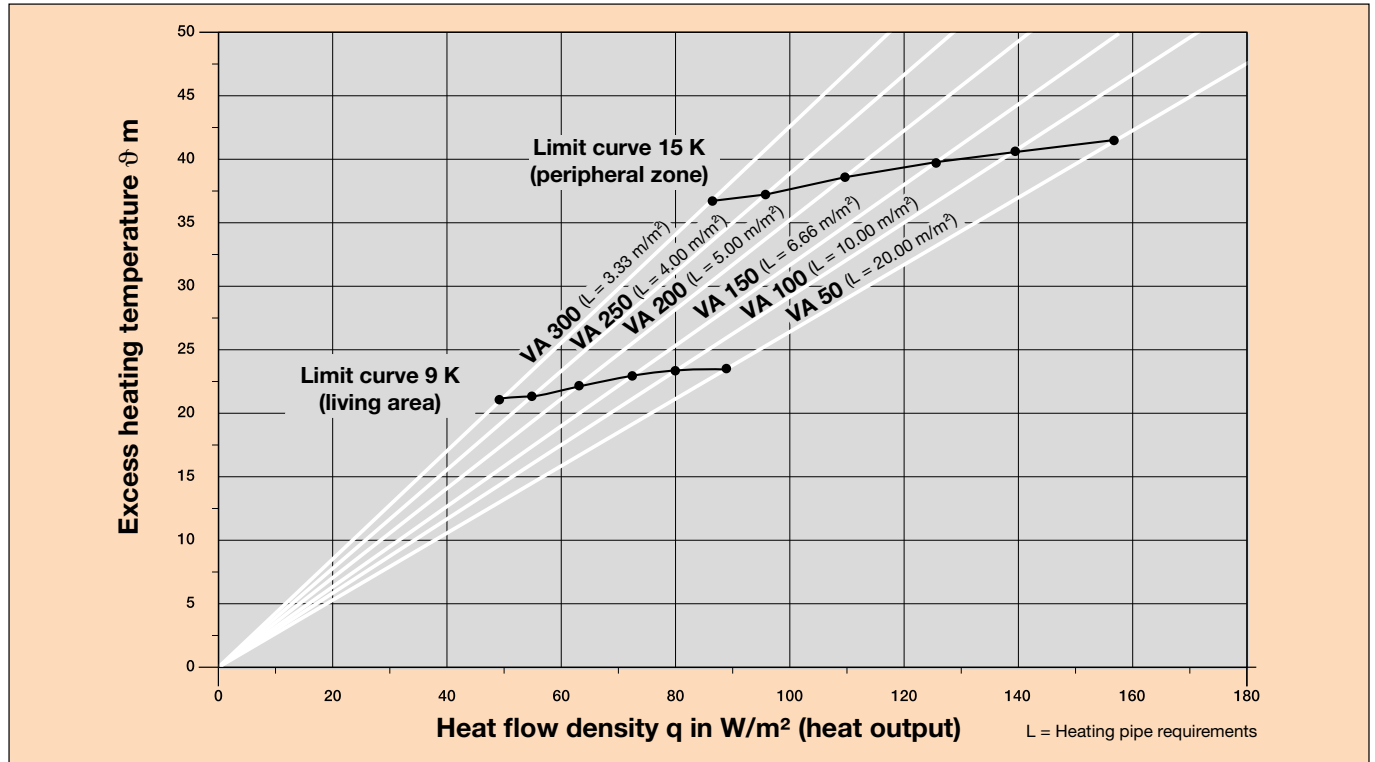

Performance data according to DIN EN 1264

Room temp. °C	Supply temp. °C	Living area														Peripheral zone														
		25	30	35	40	45	50	55	60	65	70	75	80	85	90	95	100	105	110	115	120	125	130	135	140	145				
Avg. surface temp. °C		22.7 23.6 24.5 25.5 26.4 27.3 28.2														29.1 30.0 30.9 31.8 32.7														
20	30	Installation spacing VA mm	100	50																										
		Max. heating circuit area m²	4.5	2.5																										
		Max. heating circuit length m	52	57																										
20	35	Installation spacing VA mm	200	150	150	100	50																							
		Max. heating circuit area m²	12	8	5.5	3.5	2.5																							
		Max. heating circuit length m	67	61	44	42	57																							
20	40	Installation spacing VA mm	300	250	200	150	150	100	50																					
		Max. heating circuit area m²	16	15	12	9	6.5	5	2.5																					
		Max. heating circuit length m	61	67	67	67	51	57	57																					
20	43	Installation spacing VA mm	300	300	250	200	150	150	100	100	50	50																		
		Max. heating circuit area m²	21	18	15	12	10	7	6	4.5	3	2																		
		Max. heating circuit length m	77	67	67	67	74	54	67	52	67	47																		

Limit curve living area/peripheral zone

Data does not replace precise planning according to DIN EN 1264.

**Presumed marginal conditions:**  
 Pressure loss: max. 250 mbar  
 Sub insulation R(U): 0.75 m<sup>2</sup>KW / (1.33 W/m<sup>2</sup>K)

tu: 15 °C  
 Single connection length: 3 - 4 m



## Cooling output of BEKOTEC-EN 12 F PS

### Notes:

- Average cooling output of 30 - 40 W/m<sup>2</sup> possible with ceramic coverings
- This lets the room temperature be lowered by approx. 3 °C
- Best cooling and heating values with ceramic coverings
- Normal cooling water temperature with approx. 18 °C.
- Ideal for use with heat pumps

The following performance data were determined in W/m<sup>2</sup> based on the installation spacing VA and the temperature difference  $\Delta T$  (room temperature cooling water temperature) according to DIN EN 1264.

### Heating pipe $\varnothing = 10$ mm

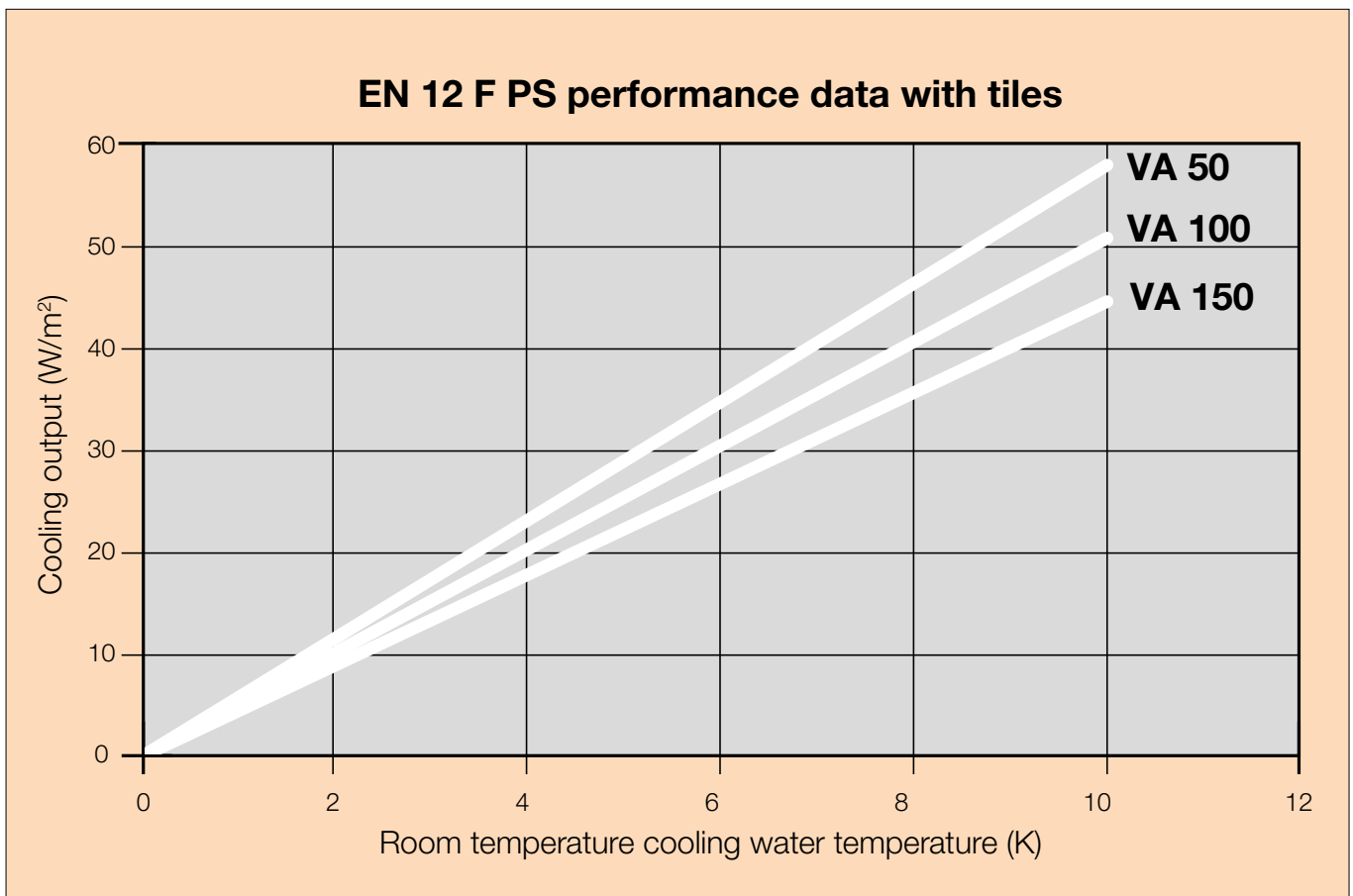

Performance data according to DIN EN 1264



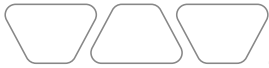

## Accessories

System components for Schlüter-BEKOTEC

### Schlüter®-BEKOTEC-ZRKL

Schlüter-BEKOTEC-ZRKL is a pipe clamping strip for securing the pipes on the levelling panel. The clamping strips are self-adhesive.

BEKOTEC-ZRKL		Heating pipe diameter
BT ZRKL	Length: 20 cm Number of pipe spaces: 4 units	Ø 14–16 mm
BT ZRKL1012	Length: 80 cm Number of pipe spaces: 32 units	Ø 10–12 mm



BEKOTEC-ZRKL

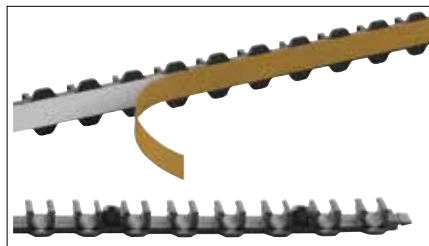

BT ZRKL1012

### Schlüter®-BEKOTEC-THERM-RH

Schlüter-BEKOTEC-THERM-RH are plastic heating pipe clips, with barbs for the systems EN 2520 P/EN 1520 PF. They are used for anchoring 16 mm heating pipes in critical areas. Size 75 is to be used over the studs, size 17 is for individual fixation.

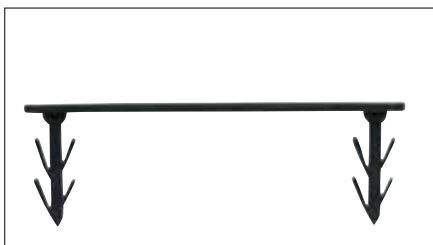

BTZ RH 75/100



BTZ RH 17/100

### Schlüter®-BEKOTEC-THERM-ZW

Schlüter-BEKOTEC-THERM-ZW is an angle clip of synthetic material for defined 90° bends of the heating pipes in diameters 10, 12, 14 or 16 mm in the distributor cabinet. The angle clip is easy to attach to the heating pipes from the side. The use of the clips is recommended to facilitate installation in the distributor cabinet if the thickness of the screed layer is relatively low.

BEKOTEC-THERM-ZW	Heating pipe diameter
BT ZW 1418	Ø 14–16 mm
BT ZW 1014	Ø 10–12 mm



BT ZW

### Schlüter®-BEKOTEC-THERM-ZDK

Schlüter-BEKOTEC-ZDK is a double-sided adhesive tape for adhering the studded panel to the substrate or the levelling panels.

BEKOTEC-ZDK	EN 23F	EN 18 FTS	EN 12 FK
BT ZDK 66	X	X	X



BT ZDK 66

### Schlüter®-BEKOTEC-BTS

Schlüter-BEKOTEC-BTS is a 5 mm thick, orange insulation layer of closed cell polyethylene foam for installation below the studded screed panels Schlüter-BEKOTEC-EN 2520 P/-EN 1520 PF and -EN 23 F. The use of BEKOTEC-BTS results in a significant improvement of sound insulation. The material can be used if the required construction height is not sufficient for a thick insulation layer of polystyrene or mineral fibre. The maximum floor load must be limited to 2 kN/m<sup>2</sup>.

**Material thickness:** 5 mm

**Roll width:** 1 m

**Supplied length:** 50 m

**Bulk density:** 20 -25 kg/m<sup>3</sup>

**Thermal resistance:** 0.10 m<sup>2</sup> K/W

**Fire protection class:** E

**Dimensional stability:** under load up to 55 °C

**Dynamic rigidity:** 90 MN/m<sup>3</sup>

**Impact sound improvement measure according to DIN EN ISO 10140-1:** up to 23 dB



BTS 510

### Schlüter®-DILEX-DFP

Schlüter-DILEX-DFP is a movement joint profile to be installed at door areas or used to divide screed areas. Depending on the covering assembly, heights between 60 and 100 mm can be selected.



Schlüter-DILEX-DFP

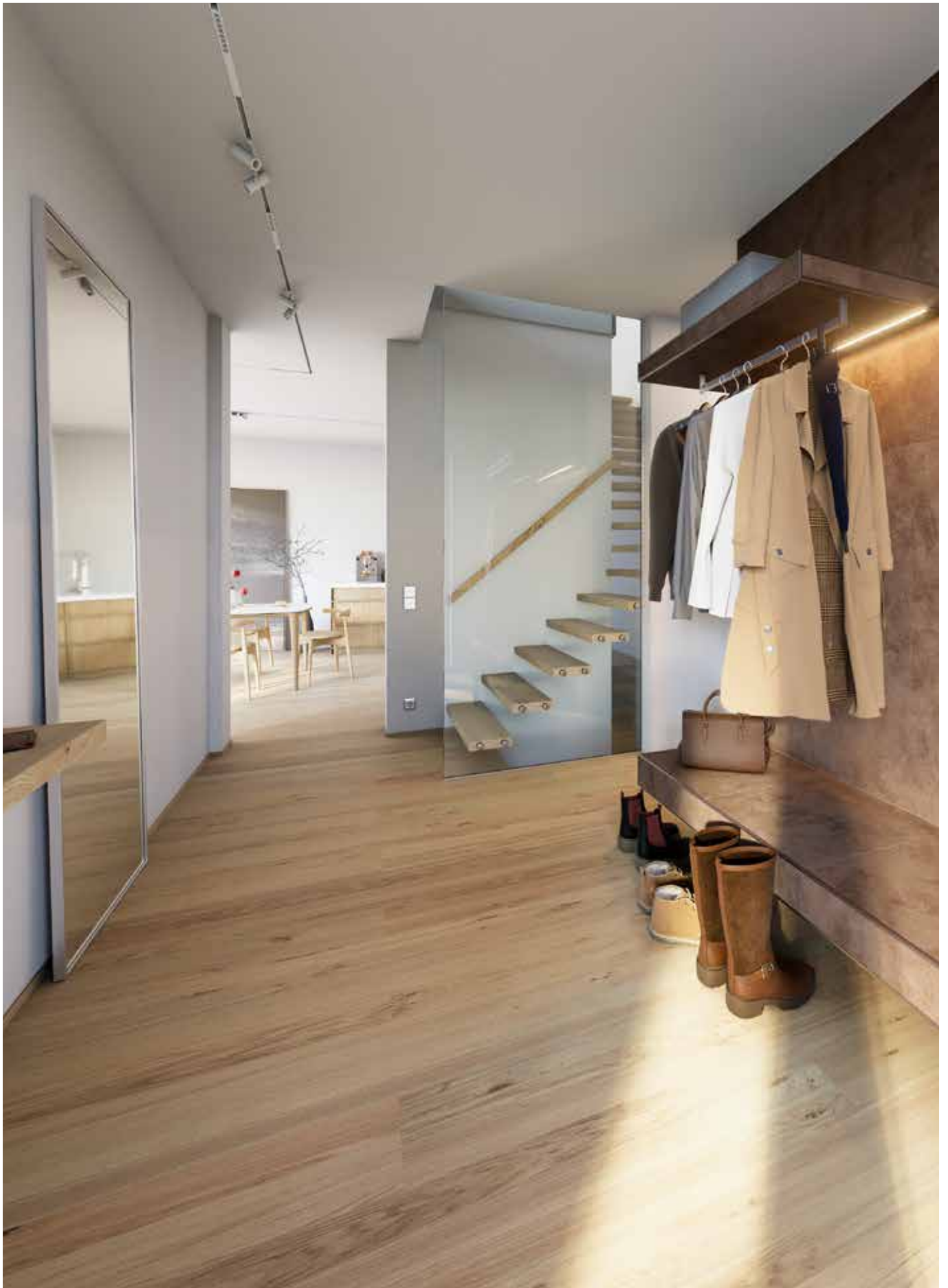

## Technical data – Heating pipe HR

Schlüter-BEKOTEC-THERM-HR heating pipes are made of a special, highly flexible polyethylene material. The typical molecular structure of this material with branched octenes and a close molecular weight distribution allows for the production of pipes with high thermal resistance and pressure resistance. The applicable quality requirements have been far exceeded. Consequently, no cross linking of the molecular structure is necessary for this high quality material.

BEKOTEC-THERM-HR heating pipes are coated with an oxygen barrier of EVOH. This oxygen barrier is connected to the base pipe with a special process. Together, the base pipe, the adhesion promoter, and the oxygen barrier form an inseparable unit. Therefore, it is not necessary to implement a system separation because of oxygen diffusion.

Our high value BEKOTEC-THERM-HR heating pipes are characterised by the following properties:

- Easy, time saving installation thanks to low internal stress in the pipes
- Installation is feasible with outside temperatures to  $-10\text{ °C}$
- Minimal flow resistance thanks to high surface gloss in the interior of the pipe
- Five-layer pipe with internal oxygen barrier layer
- Available roll sizes: 70 m, 120 m, 200 m, 600 m
- Linear metres imprinted on pipe

The Schlüter-BEKOTEC-THERM system heating pipe is

- Safe
- Flexible
- Durable
- Low in tension



### Additional benefits

- Highly temperature resistant and enormously durable (life expectancy)
- Non toxic and physiologically harmless
- For floor heating and cooling systems and concrete core cooling

### Standards, testing and monitoring

- The system heating pipes Schlüter-BEKOTEC-THERM-HR are manufactured in accordance with DIN 16833, tested in accordance with DIN 4726 and under continuous quality control.

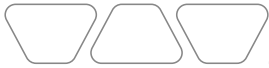

## Technical data – Heating pipe HR

### Fatigue testing

The durability of pipe materials is tested in long term fatigue tests, with results displayed in the so called creep rupture strength diagrams. In order to determine the requirements of prolonged stress exposure, the mechanical properties of the material had to be analysed over the long term. The diagram below shows the pressure resistance and temperature resistance with the projected life expectancy of the material.

PR RT was the first substance ever to be specially designed for the production of pipes for application in heated floor assemblies. Due to its unique molecular structure with branched octenes distributed evenly over its main chains and the close distribution of molecular weight, the material is highly durable even under elevated temperature and pressure conditions.

### Example

A conventional heating system with an interior pipe pressure of max. 2.5 bar and dimensions of  $\varnothing 16 \times 2$  mm has a calculated equivalent stress of 0.875 MPA. Even with a safety factor of 250 % (**2.19 MPa**) no failure of the Schlüter-BEKOTEC-THERM heating pipe has been documented at a heating water temperature of 50 °C (see diagram).

The requirements for these heating pipes are specified in the industry standards DIN 16833, DIN 16834 and DIN 4724. Endurance tests have shown that the pipes far exceed the requirements of DIN 4726.

### Creep rupture strength diagram Schlüter®-BEKOTEC-THERM-HR

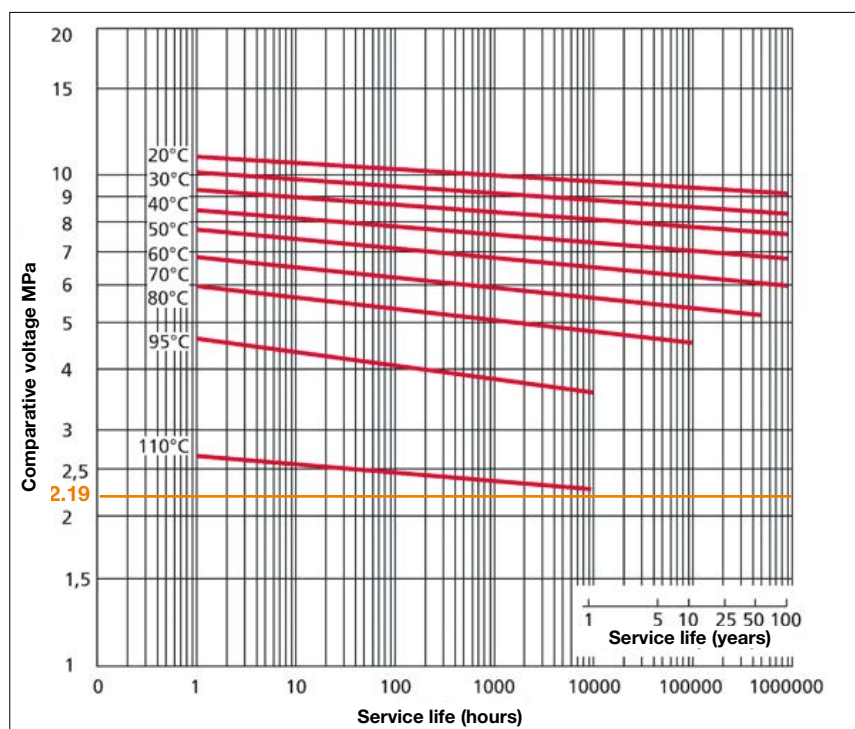

# Technical data – Heating pipe BEKOTEC-THERM-HR

## Physical and mechanical properties

Properties	Units	Values
Density	g/cm <sup>3</sup>	0.933
Thermal conductivity	W/(mK) at 60 °C	0.40
Coefficient of thermal expansion	10 <sup>-4</sup> /K	1.95
Max. operating temperature	°C	70
Yield strength (1) (2)	Mpa	16.5
Tensile strength (1) (2)	%	13
Smallest forming radius	Ø	5 x outside diameter
Oxygen permeability (3)	g/m <sup>3</sup> d	< 0.1
Stress crack resistance	h	> 8760 (no break)
Water content (Ø 16 mm)	l/m	0.113
Water content (Ø 14 mm)	l/m	0.079
Water content (Ø 12 mm)	l/m	0.064
Water content (Ø 10 mm)	l/m	0.043

- (1) Test speed 50 mm/min.  
 (2) Sample compression plate: 2 mm thick  
 (3) Tested with co extruded EVOH layer

## Chemical resistance\*

Chemicals	
Acetone	++
Ammonia	+
Gasoline	-
Chromic acid	++
Ethylene glycol	++
Ferrous sulphate	++
Formaldehyde 30 %	++
Isopropyl alcohol	++
Sodium hydroxide solution	++
Propylene glycol	++
Nitric acid 5 %	++
Hydrochloric acid	++
Acids, inorganic/organic	++
Sulphuric acid 30 %	++
Hydrogen	++

<sup>1)</sup>The chemical resistance tests were conducted according to ASTM D543 60T (ASTM D543 87) at 23.9° C.

++ resistant<sup>1)</sup>

+ conditionally resistant<sup>1)</sup>

- not resistant<sup>1)</sup>

\* with reference to heating medium (interior of heating pipe)

## Storage

The pipes may not be exposed to direct sunlight for a long time. Boxes should be protected from moisture.

## Pressure loss

Pressure loss diagram, see Attachment I-I, page 160.

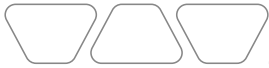

# Technical data – Distribution cabinet VSE

Distribution cabinet for wall installation

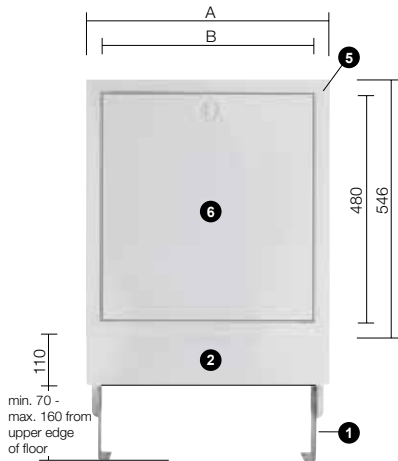

Schlüter-BEKOTEC-THERM-VSE is a distributor cabinet for in wall installation to fit a Schlüter heating circuit distributor HVT/DE or HVP and the associated control components. The distributor cabinet is made of galvanised steel with two stabilising double edges and pre-cut openings in the sidewalls for routing connector cables.

The set includes:

- Two lateral installation legs ①, height adjustable from 0 to 90 mm,
- Screed finishing panel ②, depth adjustable and removable,
- Heating pipe track,
- Documentation folder,
- Adjustable attachment tracks ③ for Schlüter heating circuit distributors and an additional installation track D for simple plug in assembly of the Schlüter control modules.
- Frame ⑤ and door ⑥ (packaged separately) are powder coated and are mounted subsequently at 4 insertion points, using wing screws. They are adjustable for depths from 110 mm to 150 mm. The door ⑥ is locked with a thumb turn.

Colour: Traffic white RAL 9016

**Important:** A lock with the corresponding keys is available as a special accessory (item no. BTZS).

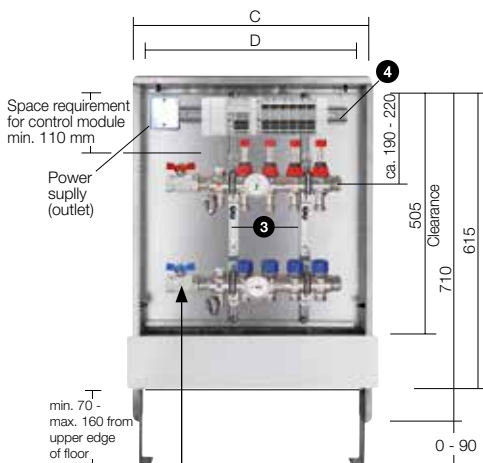

Dimensions of the ball valves:  
DN 20 l = 50 mm  
DN 25 l = 73 mm

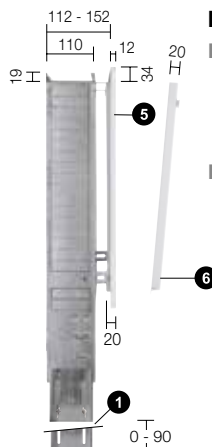

### Installation note:

- The adjustable installation legs ① must be adjusted to the planned floor assembly. The finished floor assembly must end in front of the screed finishing panel ②.
- At least 110 mm of space should be left above the heating circuit distributor for the installation of the control modules.



## Schlüter®-BEKOTEC-THERM-VSE distributor cabinet for wall installation

Distribution cabinet					Maximum number of heating circuits (heating circuit distributors HVT/DE and HVP)			
Art.-No.	Outside frame A = mm	Inside frame B = mm	Outside measure of wall opening C = mm	Inside measure of cabinet D = mm	Without additional installations	with PW* Vertical	with PW* Horizontal	incl. FRS
BTVSE 4 WW	513	445	490	455	4	3	0	2
BTVSE 5 WW	598	530	575	540	6	5	3	3
BTVSE 8 WW	748	680	725	690	9	8	6	5
BTVSE 11 WW	898	830	875	840	12	11	9	8
BTVSE 12 WW	1048	980	1025	990	12	12	12	12

\* PW = Connection set for calorimeter.

## Technical data – Distribution cabinet VSV

Distributor cabinet for surface mounting

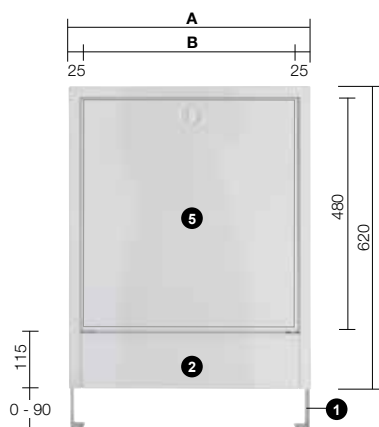

Schlüter-BEKOTEC-THERM-VSV is a distributor cabinet for surface mounting to house the Schlüter heating circuit distributor manifold BEKOTEC-THERM-HVT/DE or -HVP and the matching control components. The distributor cabinet is made of galvanised steel, and is powder coated on the inside and outside.

The set includes:

- Two lateral installation legs ①, height adjustable from 0 to 90 mm,
- Screed finishing panel ②, removable,
- Heating pipe track,
- Documentation folder,
- Adjustable attachment tracks ③ for Schlüter heating circuit distributors and an additional installation track D for simple plug in assembly of the Schlüter control modules.

Cabinet depth = 125 mm. The door ⑤ is locked with a thumb turn.

Colour: Traffic white RAL 9016

**Important:** A lock with the corresponding keys is available as a special accessory (item no. BTZS).

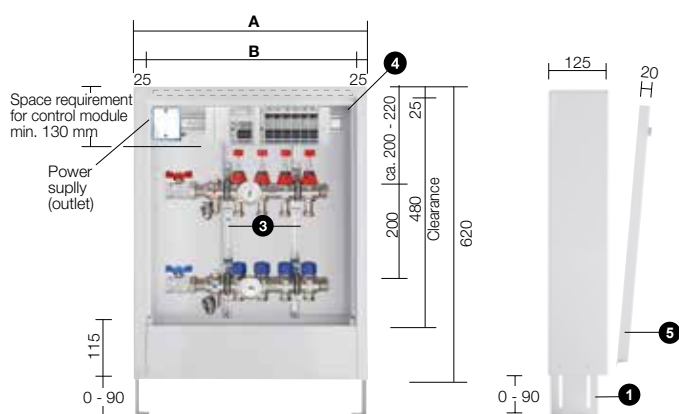

### Installation note:

- The adjustable installation legs ① must be adjusted to the planned floor assembly. The finished floor assembly must end in front of the screed finishing panel ②.
- At least 130 mm of space should be left above the heating circuit distributor for the installation of the control modules.

Schlüter®-BEKOTEC-THERM-VSV distributor cabinet for surface mounting

Distribution cabinet			Maximum number of heating circuits (heating circuit distributors HVT/DE and HVP)			
Art.-No.	External dimensions A = mm	Inside dimensions B = mm	Without additional installations	with PW* Vertical	with PW* Horizontal	FRS
BTVSV 4 VW	496	445	4	3	–	2
BTVSV 5 VW	582	531	5	4	2	3
BTVSV 8 VW	732	681	8	7	5	5
BTVSV 11 VW	882	831	11	10	8	8
BTVSV 12 VW	1032	981	12	12	11	12

\* PW = Connection set for calorimeter.



# Technical data – Fixed-value control station FRS

## Function and use

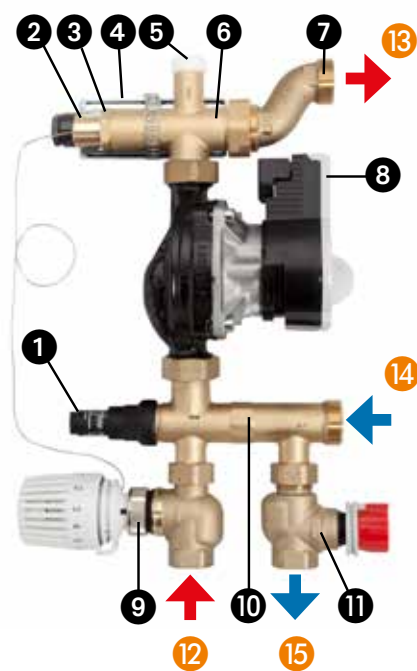

- ❶ Balancing valve
- ❷ Immersion sensor (remote sensor) G1/2 Ø 12
- ❸ Closing screw G3/8
- ❹ Attach safety temperature monitor STW on the front or back with installation tape
- ❺ Venting screw nipple 3/8
- ❻ Angled connector fitting G1
- ❼ Eccentric G1
- ❽ Circulating pump
- ❾ Thermostat valve with remote sensor
- ❿ Base housing
- ⓫ Control valve
- ⓬ Boiler, hot flow leg (primary)
- ⓭ Surface heating system, hot flow leg (secondary)
- ⓮ Surface heating system, return leg (secondary)
- ⓯ Boiler, return leg (primary)

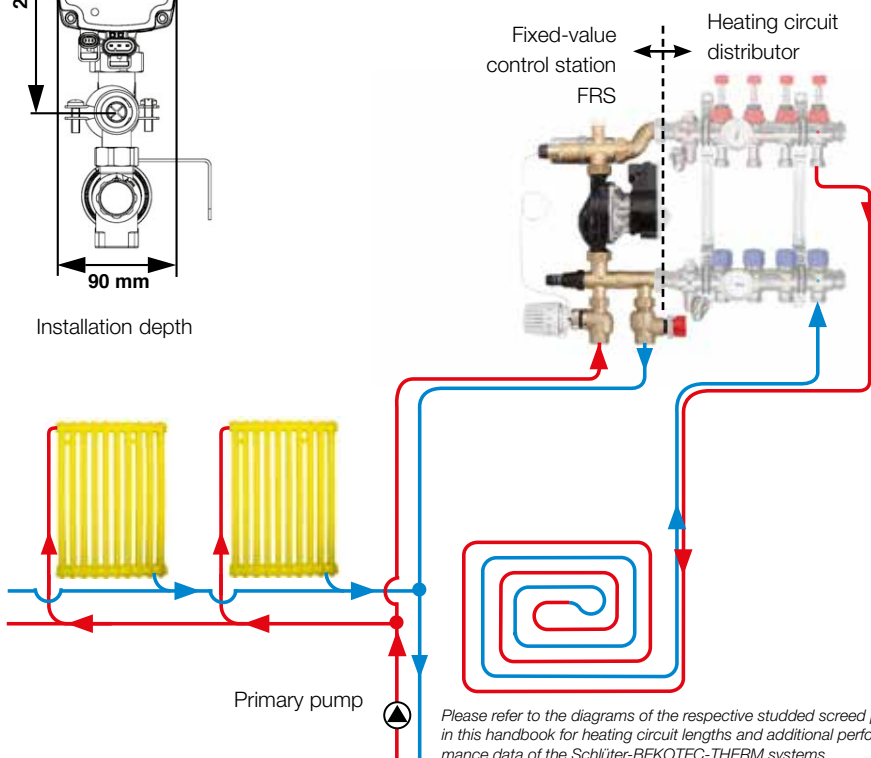
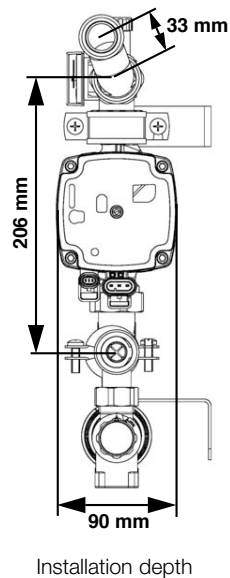

Please refer to the diagrams of the respective studded screed panels in this handbook for heating circuit lengths and additional performance data of the Schlüter-BEKOTEC-THERM systems.

Schlüter-BEKOTEC-THERM-FRS is a simple mixing and control system to supply the Schlüter-BEKOTEC-THERM ceramic thermal comfort floor with the required low supply temperatures.

By mixing heating water from hotter parts of the heating system, for example from the radiator volume, the system is able to provide the BEKOTEC heating circuit distributors with the required low supply temperatures.

The number of heating circuits for installation in on-wall or concealed distributor cabinets is limited to a maximum of 12.

- This solution is ideal if only a portion of the space, or individual floor levels, have heated floors, while other areas are heated with radiators.
- The fixed-value control station BEKOTEC-THERM-FRS can also be used to install a Schlüter-BEKOTEC-THERM ceramic thermal comfort floor in individual apartments.

BEKOTEC-THERM-FRS is ideally suited for combination with an existing, shared pipe network that is designed for the higher supply temperatures of radiator heaters. This enables the easy implementation of renovation projects with the Schlüter-BEKOTEC-THERM ceramic thermal comfort floor (see *sample design calculation* on page 125).

The BEKOTEC-THERM heating circuits are supplied separately by an integrated high efficiency pump.

The additionally integrated, adjustable bypass enables the flawless function of the pump even with very low volume flow in single heating circuits.

### Note:

Prior to installation, a qualified expert must review the control technology and hydronic installations. A supply pump (primary pump) must provide the supply for the water temperature control unit. The installation and assembly instructions of the manufacturer must be observed. We recommend a control mechanism via the pump outlet at the Schlüter-Control base module to the pump switch (see page 136).

## Technical data – Fixed-value control station FRS

### Function and operation

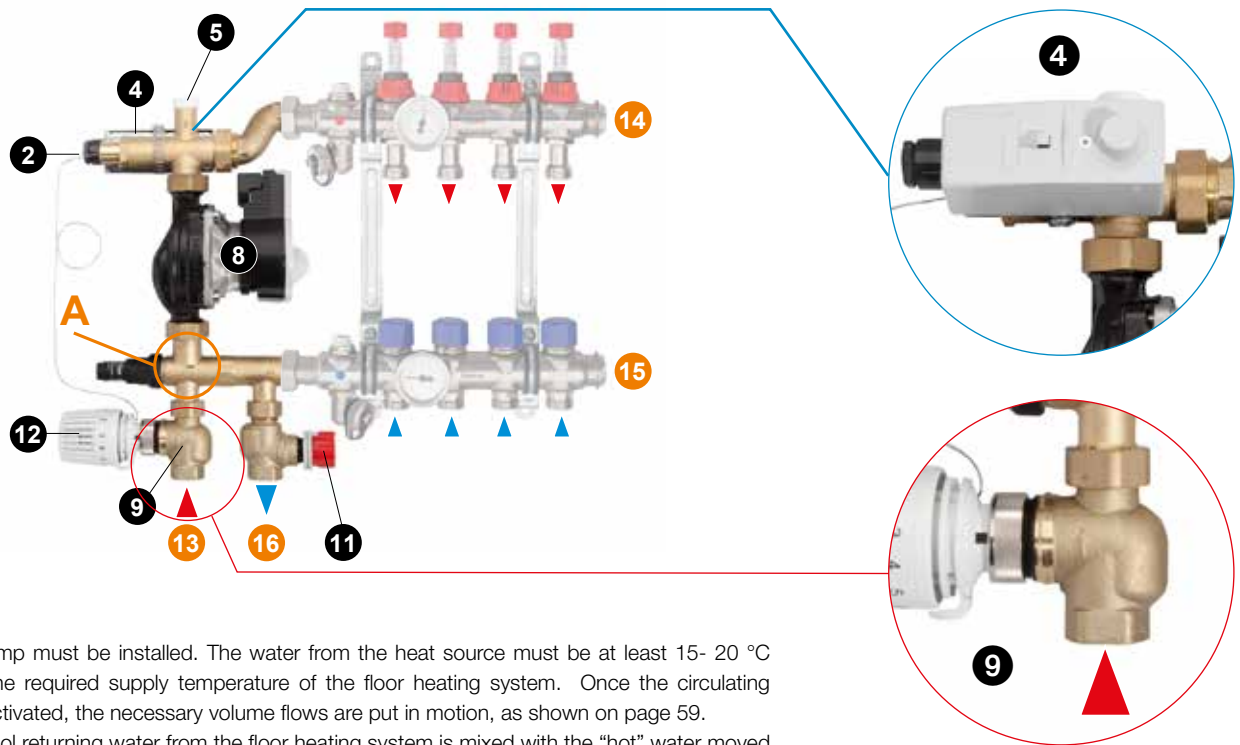

A primary pump must be installed. The water from the heat source must be at least 15- 20 °C hotter than the required supply temperature of the floor heating system. Once the circulating pump **8** is activated, the necessary volume flows are put in motion, as shown on page 59.

At point **A**, cool returning water from the floor heating system is mixed with the “hot” water moved from the supply circuit by the primary pump. Immersion sensor **2** which is connected to thermostat **12** with a capillary line, records the actual temperature.

The supply temperature set at thermostat **12** is directly compared to the temperature of the immersion sensor **2**. If necessary, thermostat valve **9** mixes in water for correction.

Next, the water enters the supply leg **14** of the Schlüter-BEKOTEC-THERM system and passes through the individual heating circuits. Once the heat has been transferred, the water flows back through the heating circuit return leg **15**. When the heating water in the floor heating circuit drops below the temperature set at thermostat **12**, part of the returning water is sent to the heat source **16** for reheating.

“Hot” supply water from the radiator circuit **13** is mixed in at point **A**.

The amount of supply water from the radiator circuit **13** depends on the quantity of water returned to the heat source for reheating. The control valve **11** balances the heating circuit.

A pre-wired safety temperature monitor **4** is supplied with the fixed-value control station. It can be installed on the back or front side of the hot leg above the pump. When the maximum supply temperature (55 °C) is exceeded, it switches the circulating pump **8** off. The circulating pump **8** provides the BEKOTEC-THERM heating circuits with optimal heating water volumes, which saves electricity.

- 2** Immersion sensor (remote sensor)  
G1/2 Ø 12
- 4** Attach safety temperature monitor STW on the front or back with installation tape
- 5** Venting screw nipple 3/8
- 8** Circulating pump
- 9** Thermostat valve with remote sensor
- 11** Control valve
- 12** Thermostat 20-55 °C (scale 1-9)
- 13** Boiler, hot flow leg (primary) \*
- 14** Surface heating system, hot flow leg (secondary)
- 15** Surface heating system, return leg (secondary)
- 16** Boiler, return leg (primary) \*\*

\* **Primary hot flow leg:**  
with high temperature from **heat source**

\*\***Primary cold leg:**  
for supplementary heating by heat source

#### Note:

Prior to installation, a qualified expert must review the control technology and hydronic installations. All work associated with installation, start up, maintenance, and repair should exclusively be performed by authorised personnel.

The assembly instructions supplied with the product must be observed. The system must be disconnected from all voltage prior to starting the installation.

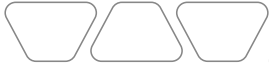

## Set up and start up

After the installation, fill the heating system in the flow direction of the flow meters and vent it at the heating circuit distributor **5** (see diagram on page 123).

Then perform a pressure test according to the specified procedure - see page 170, Attachment IV. Set the pump to constant differential pressure control  $\Delta p$ .

Please refer to the supplied operating instructions for further information on start up! (see pump diagram in Attachment I.I. on page 162).



### Note:

Do not heat the screed and floor covering during the installation. The shut-off is ensured by closing the ball valves and switching off the power.

For information about cure heating, see page 150.

Set the temperature control **12** to the desired temperature. The temperature change from scale line to scale line is approximately 5 °C. The recommended setting range of the temperature control for the ceramic thermal comfort floor is between 25 and approx. 35 °C  $\Delta$  2 - 4.

**Scale lines 1 through 9 at the thermostat correspond to 20 to approx. 55 °C.**



### Note:

The safety temperature monitor **4** is activated when the supply temperature exceeds  $\geq 55$  °C and switches the pump off. Pump operation resumes when the temperature drops below  $< 55$  °C. It can be installed on the front or reverse side.

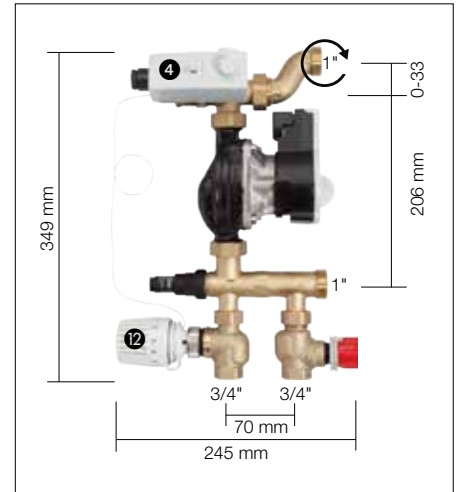

## Technical data

Parameter	Value
<b>General data</b>	
Weight	4.8 kg
Fittings material	Brass/plastic
System pressure	Max. 10 bar
<b>Temperature application range</b>	
Environment	0/+60 °C
Primary circuit	Max. 75 °C
Secondary circuit	20 – 55 °C
<b>Pressure loss</b>	
Thermostat valve	Kvs = 4.0 m <sup>3</sup> /h
Control valve	Kvs = 2.7 m <sup>3</sup> /h

## Technical data – Fixed-value control station (FRS)

### Design and layout

Due to the high temperature difference (splay) between the primary and secondary circuit (radiator floor heating circuit), the “hot” water volume, which is fed from mixing point **A** and returned to the heat source by way of the three way distributor valve, is much smaller than the total water quantity for the floor heating system.

It is important to determine the volumes for the planned splay to define the dimensions of the lines and the hydronic conditions of the system.

The water volume of the heating circuit distributor for the Schlüter®-BEKOTEC ceramic thermal comfort floor is shown in the calculations for the BEKOTEC ceramic thermal comfort floor.

If these calculations are not available, the following equation may be used on the basis of the system temperatures employed for the design:

where:  $Q_{FBH}$  = Total heat output of the  
Schlüter-BEKOTEC ceramic thermal comfort floor [W]  
 $\vartheta_{VFBH}$  = Supply temperature, secondary circuit  
(Schlüter-BEKOTEC ceramic thermal comfort floor)  
 $\vartheta_{RFBH}$  = Return temperature, secondary circuit  
(Schlüter-BEKOTEC ceramic thermal comfort floor)

Example:

$Q_{FBH}$  = Total heat output of the  
Schlüter-BEKOTEC ceramic thermal comfort floor = 5,000 W  
 $\vartheta_{VFBH}$  = Supply temperature, secondary circuit  
(Schlüter-BEKOTEC ceramic thermal comfort floor) = 35 °C  
 $\vartheta_{RFBH}$  = Return temperature, secondary circuit  
(Schlüter-BEKOTEC ceramic thermal comfort floor) = 28 °C

$$m_{FBH} = \frac{Q_{FBH}}{(\vartheta_{VFBH} - \vartheta_{RFBH}) \cdot 1.163} \text{ [kg/h]}$$

$$m_{FBH} = \frac{5000 \text{ W}}{(35 \text{ °C} - 28 \text{ °C}) \cdot 1.163} = \underline{\underline{615 \text{ kg/h}}}$$

This water quantity with the pressure loss of the least favourable BEKOTEC heating circuit provides the base data for setting the pump (see *pump characteristics*).

Since the required output also has to come from the primary circuit (radiator circuit), the water quantities for the primary circuit have to be calculated as follows:

mit:  $Q_{FBH}$  = Total heat output of the Schlüter-BEKOTEC ceramic thermal comfort floor  
 $\vartheta_{VHK}$  = Supply temperature, primary circuit (radiator)  
 $\vartheta_{RFBH}$  = Return temperature, secondary circuit (floor heating)  
(Schlüter-BEKOTEC ceramic thermal comfort floor)

Example:

$Q_{FBH}$  = Total heat output of the  
Schlüter-BEKOTEC ceramic thermal comfort floor = 5,000 W  
 $\vartheta_{VHK}$  = Supply temperature, primary circuit (radiator) = 65 °C  
 $\vartheta_{RFBH}$  = Return temperature, secondary circuit (floor heating) = 28 °C  
(Schlüter-BEKOTEC ceramic thermal comfort floor)

$$m_{HK} = \frac{Q_{FBH}}{(\vartheta_{VHK} - \vartheta_{RFBH}) \cdot 1.163} \text{ [kg/h]}$$

$$m_{HK} = \frac{5000 \text{ W}}{(65 \text{ °C} - 28 \text{ °C}) \cdot 1.163} = \underline{\underline{117 \text{ kg/h}}}$$

Due to the larger splay, the primary water volume will always be smaller than the sum of the total volume of the connected BEKOTEC heating circuits.

This makes it possible to utilise the very small pipe bores of the individual radiators for connecting Schlüter-BEKOTEC-THERM-FRS.

In the case of the data assumed for this example, a supply line with an interior diameter of 13 mm (copper pipe with Ø 15 x 1 mm) may be sufficient, considering the hydronic conditions in the primary circuit.



## Technical data – Connection set for calorimeter

### Function and use

Schlüter-BEKOTEC-THERM-PW is a connection set for retrofitting the calorimeter, partly pre-installed. Calorimeters are installed to determine energy consumption and to help calculate the heating costs with a connected distributor (e.g. HVT/DE or HVP). For this purpose, the spacer pipe is removed and replaced with a calorimeter with a length of 110 mm. The counter determines the energy consumption on the basis of the water flow and the temperature differences.

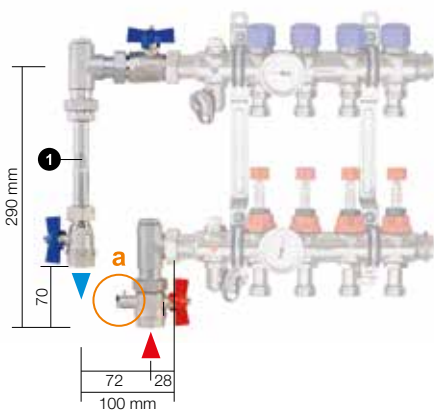

**BTZPW 20 V vertical** consists of:

- Spacer pipe ① 110 mm, with external thread 3/4" (DN 20),
- 2 angles 90°
- 2 ball valves 3/4" (DN 20)
- 1 ball valve 3/4" (DN 20) with sensor connection for directly immersed sensors (5 mm, M10 x 1)
- Separate sensor connector 1/2" for immersion sensors (5 mm, M10 x 1)
- 2 flat gaskets 1" (DN 25)

### Note

The installation follows the flow direction.

The connection set for the measuring mechanism of the calorimeter is usually connected to the return flow. Depending on the connecting situation, it may be necessary to install the return distributor bar above or below.

The installation instructions for the calorimeter must be observed. The space requirements for the selection of the distributor cabinet must be taken into account (see table on pages 120 – 121).

PW = connection set for calorimeter

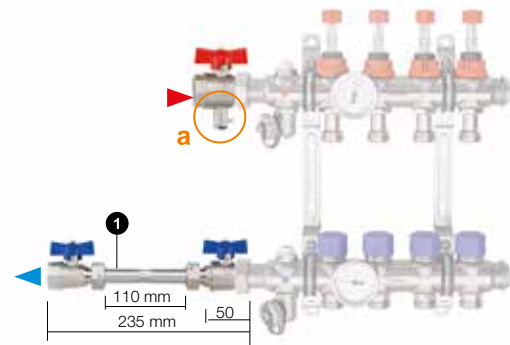

**BTZPW 20 H horizontal** consists of:

- Spacer pipe ① 110 mm, with external thread 3/4" (DN 20)
- 2 ball valves 3/4" (DN 20)
- 1 ball valve 3/4" (DN 20) with sensor connection for directly immersed sensors (5 mm, M10 x 1)
- Separate sensor connector 1/2" for immersion sensors (5 mm, M10 x 1)
- 2 flat gaskets 1" (DN 25)

### Item "a"

#### Measuring position for the supply temperature

For the installation of the immersion sleeves, plug "a" is removed from the ball valve supply leg.

The immersion sleeve of the calorimeter is now installed in this space.

i

#### Note:

The data must match the specifications of the corresponding calorimeter brand.

# Technical data – Heating circuit distributor HVT/DE

Heating circuit distributor DN 25 of stainless steel – HVT/DE

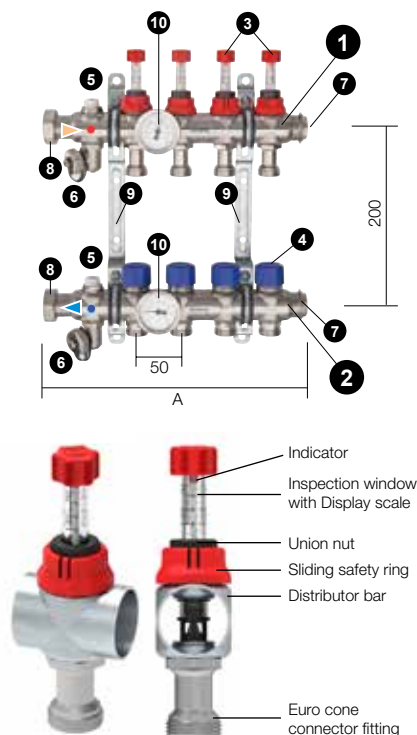

Schlüter-BEKOTEC-THERM-HVT/DE is a heating circuit distributor DN 25 of stainless steel with hot leg **1** and cold leg **2** bars, outside diameter 35 mm.

The integrated and pre-assembled set includes:

- Hot leg flow meter **3** with transparent scale for regulating flow volumes, adjustable from 0.5 to 3.0 litres per minute.
- Thermostat valves **4**, manually adjustable for every heating circuit, to match the electrically controlled Schlüter actuators
- one manual vent **5**, nickel plated brass for supply and return flow,
- Fill and drain cock **6** 1/2" (DN 15), rotatable, nickel plated brass,
- Stop plug **7** 3/4" (DN 20), nickel plated brass,
- Connection to the distribution system with flat sealing union nut **8** 1" (DN 25)
- Heating circuit outlets with spacing 50 mm, consisting of Eurokonus connector DN 20 AG with matching Eurokonus for Schlüter clamp connections.
- The carton also includes two distributor manifold brackets **9** with sound insulation insert to match the Schlüter distributor cabinet and an additional wall mounting set.
- Integrated thermometer **10**, suitable for mounting on either side

A matching connector set with the necessary accessories for connecting the heating circuits is available as a separate item in all distributor sizes.

A separate ball valve set must be ordered for the supply leg and for the return leg.

#### Note:

for the pressure loss characteristics of the HVT/DE heating circuit distributor, see diagrams of Attachment I.I (see page 161).

Heating circuit distributor	2-circuit	3-circuit	4-circuit	5-circuit	6-circuit	7-circuit	8-circuit	9-circuit	10-circuit	11-circuit	12-circuit
Art.-No.	BTHVT 2 DE	BTHVT 3 DE	BTHVT 4 DE	BTHVT 5 DE	BTHVT 6 DE	BTHVT 7 DE	BTHVT 8 DE	BTHVT 9 DE	BTHVT 10 DE	BTHVT 11 DE	BTHVT 12 DE
Length without ball valve A = mm	215	245	295	347	397	447	497	547	597	647	697

The installation depth is approx. 70 mm.

## Lockable volumetric flow meter - set up/locking

The Memory volumetric flow meter is integrated into the supply heating circuit distributor bar and is used to display, set up, or lock the volume flows of floor heating or cooling systems. The open volumetric flow meter shows the water volume flow in litres per minute when the circulating pump is running. The water volume can be decreased by turning the dial clockwise, while turning the dial counter-clockwise increases the water volume.

Locking the flow meter permanently establishes the water volume setting with no risk of losing the setting.

#### Setting the flow

**Fig. 1** Pull off the sliding safety ring toward the top (red, wide ring)

**Fig. 2** Loosen the locking cap anti-clockwise, turn toward the top.

**Fig. 3** Set the flow value by turning the red knob

**Fig. 4** Turn the black locking cap clockwise to the stop.

**Fig. 5** Push the sliding safety ring down

#### Locking

**Fig. A** Turn the knob clockwise to the stop: The heating circuit is now locked.

**Fig. B** Turn handwheel counter clockwise to the stop. The heating circuit is now open with the set up flow value.

#### Pressure loss diagrams

Pressure loss diagrams, see pages 161

**i**

#### Note:

Not required if using BEKOTEC-EAHB.





# Technical data – Heating circuit distributor HVP

Heating circuit distributor DN 25, plastic – HVP

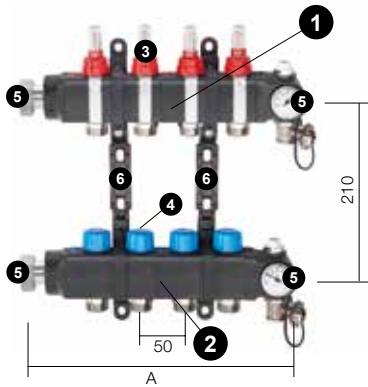

Schlüter-BEKOTEC-THERM-HVP is a heating circuit distributor made of fibreglass-reinforced plastic. Each heating circuit distributor comprises a connection set and 1 to 12 hot leg **1** and cold leg **2** modules as well as installation brackets.

Due to the modular design, each heating circuit terminal (spacing: 50 mm) is rotatable by 180° **A**, suitable for connection on both sides **B** and secured by the integrated attachment elements **C**. The hot leg module comprises a flow meter **3** with transparent scale, adjustable from 0.5 to 5.0 l/min.

The cold leg module **2** consists of an integrated thermostat valve with cover cap **4**, matching the electronically controlled Schlüter actuators.

The connection set **5** comprises the connection modules with a 1" flat-sealing union nut as well as end modules with a 1/2" fill and drain tap (rotatable) and a temperature gauge for the hot and cold leg, respectively. A matching connector set with the necessary accessories for connecting the heating circuits is available as a separate item in all distributor sizes (to be ordered separately). A separate ball valve set DN 25 or DN 20 and an installation bracket set **6** in either a flush (KF) or raised (KH) version are available separately for installation in the distributor cabinet or on plastered walls.

See diagrams of Attachment I.I on page 161 for the pressure loss characteristics of the HVP heating circuit distributor.

Number of heating circuit distributors	2-circuit	3-circuit	4-circuit	5-circuit	6-circuit	7-circuit	8-circuit	9-circuit	10-circuit	11-circuit	12-circuit
Length without ball valve A = mm	202	252	302	352	402	452	502	552	602	652	702

## Overview of BEKOTEC-THERM-HVP components



1-circuit module BT HVP



2-circuit module BT HVP



4-circuit module BT HVP



Schlüter-BEKOTEC-THERM-HVP-SET for plastic distributor

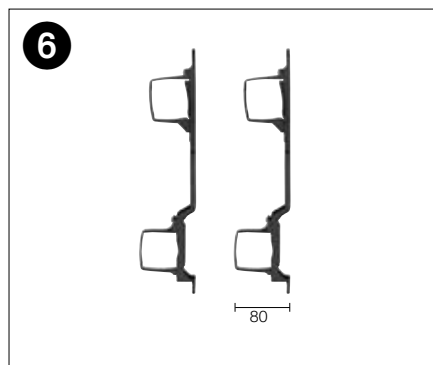

BT HVP KF 80 mm installation depth - not in combination with EAHB.

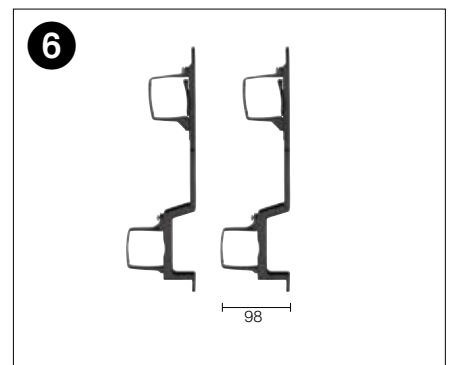

BT HVP KH 98 mm installation depth - preferred for on-wall installation  
Necessary when using the actuators EAHB

## Technical data – Heating circuit distributor HVP

### Installation

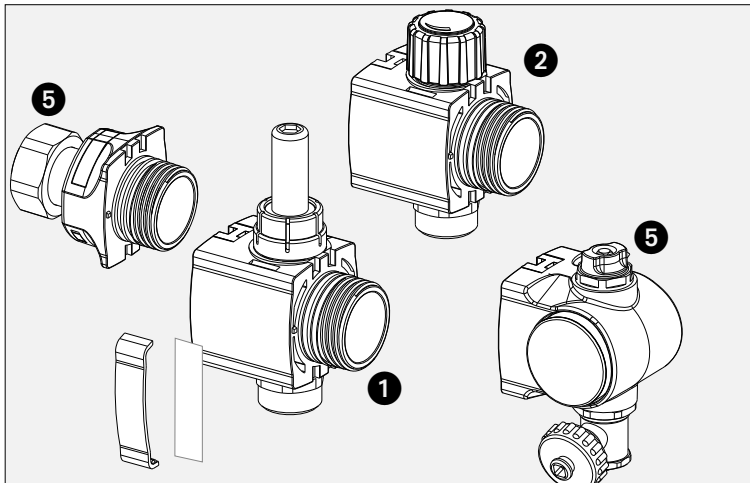

The installation of the heating circuit distributor uses the following components:

- Connector set **5**
- 1 to 12 hot leg and cold leg modules **1 + 2**
- Installation bracket **6**

Due to the modular design, each heating circuit terminal is suitable for connection on both sides **A**, rotatable by 180° **B**, and secured by the integrated attachment elements **C**.

See installation instructions for heating circuit distributor DN 25 – HVP for information on further connection methods.

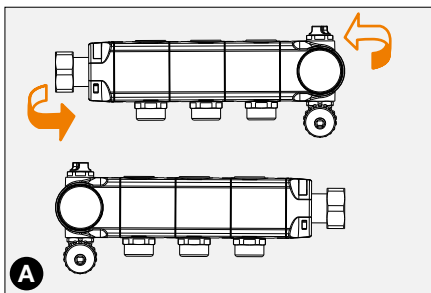

**A** Suitable for connection on both sides

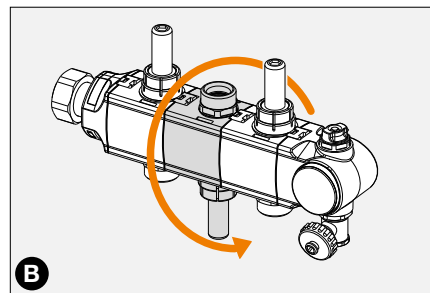

**B** Heating circuit terminal rotatable by 180°

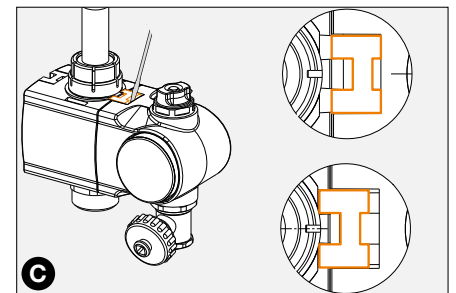

**C** Locking the attachment elements



## Technical data – Heating circuit distributor HVP

### Lockable volumetric flow meter - set up/locking

The volumetric flow meter is integrated into the supply heating circuit distributor bar and is used to display, set up, or lock the volume flows of floor heating or cooling systems.

The open flow meter shows the water volume flow in litres per minute when the circulating pump is running. The water volume can be decreased by turning the dial clockwise, while turning the dial counter-clockwise increases the water volume. Locking the flow meter permanently establishes the water volume setting with no risk of losing the setting.

#### Setting the flow

**Figure 1** Pull off the red sliding safety ring toward the top.

**Figure 2** Set the previously calculated flow volume in l/min at the inspection window with the (black) adjustment dial.

**Figure 3** Attach the red cap and push it down.

This locks the settings and prevents inadvertent changes.

**Figure 4** The display ring of the inspection window can be set to the target value for orientation at a later date.

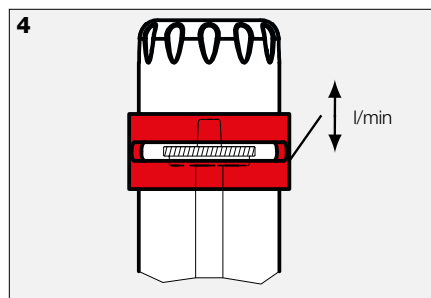
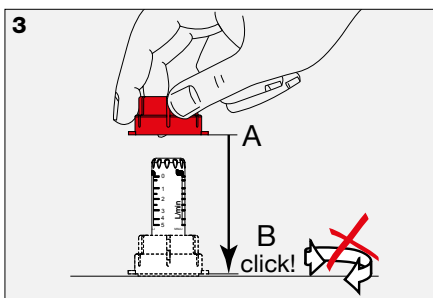
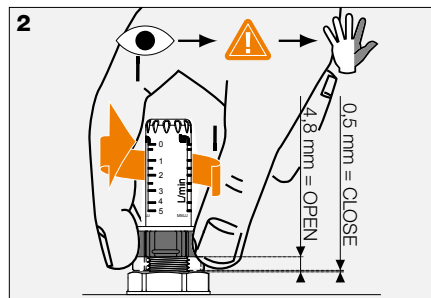
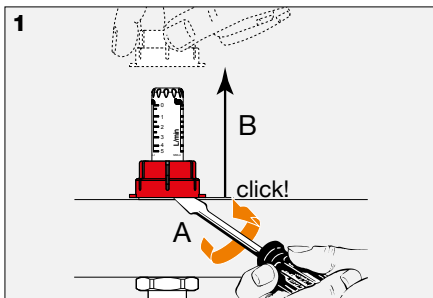

**Note:**

Not required if using  
BEKOTEC-THERM-EAHB.

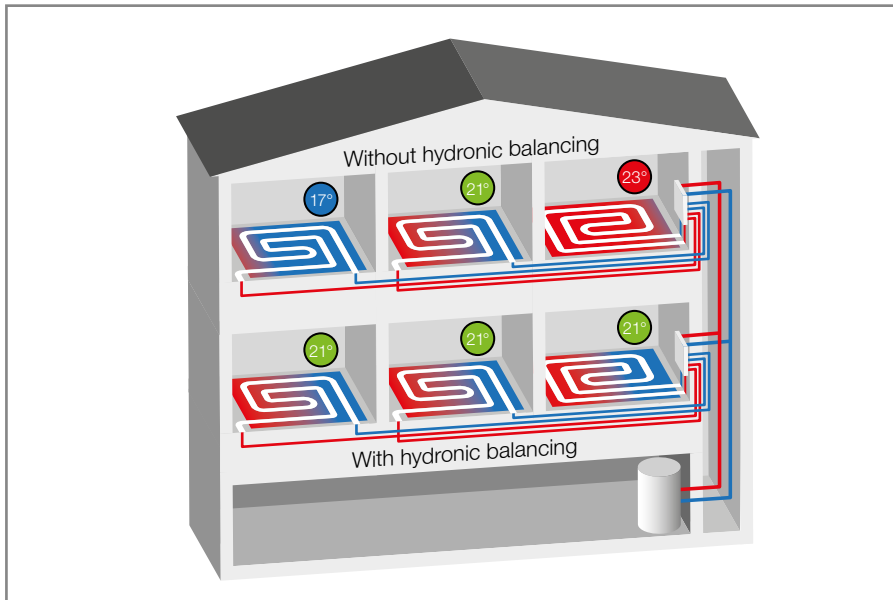

## Schlüter®-BEKOTEC-THERM - hydronic balancing

What is hydronic balancing?



The efficiency of a heating or cooling system depends largely on its hydronic balancing. Since adjustment provides every heating circuit with exactly the right supply volume, it makes the heating system especially responsive and energy efficient. Water in a heating system always uses the path of least resistance, which means it will flow more easily through short heating circuits than long ones. If this causes overly warm water to flow back to the boiler, the heat generated in the boiler can no longer be absorbed by the water and the boiler shuts off. As a result, a heating system without hydronic balancing "cycles" too much and becomes inefficient.

There are various options for hydronic balancing. In addition to conventional static mode, there is also intelligent adaptive balancing. The below table includes further explanations:

	Required distributor setting	Calculation required	Adaptive balancing	Easy to implement	Self-learning
	✓	✓			
			✓	✓	✓

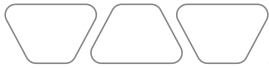

## Technical data – EAHB actuator

Energy efficiency with adaptive controls

TYPE	EAHB 230 V, NC, M 30 x 1.5
Version	NC (normally closed)
Valve connector	Union nut M 30 x 1.5
Voltage	230 V AC, 50 Hz
Switch-on current	130 mA for max. 200 ms
Max. output	1.7 W
Opening and closing time	approx. 3 min
Actuating path	≥ 3.5 mm
Actuating force	110 N
EAHB closed height	10.8 mm
Valve closed height	11.8 mm
Media temperature	10 to 60 °C (supply temperature limiting is activated in the Automatic position)
Storage temperature	-25 to 60 °C
Ambient temperature	0 to 50 °C
Relative humidity	10 to 100 %, non-condensing
Protection rating/class	IP 54 / II
Installation position	Can be installed in any position
Connection cable	Flexible, black, 1 m with ferrules
Supply line sensor cable	Flexible, black with red stripe, 0.4 m
Return line sensor wire	Flexible, black with blue stripe, 0.4 m
Temperature sensors	NTC 10k (at 25 °C), clip for outer pipe diameter 10 to 20 mm
Folding lever	toward front Manual valve opening

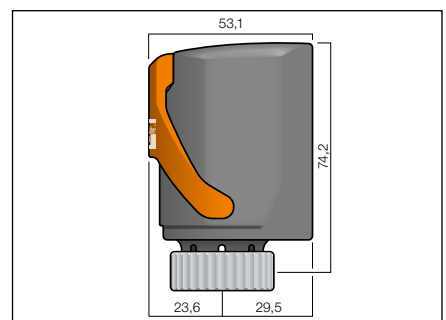
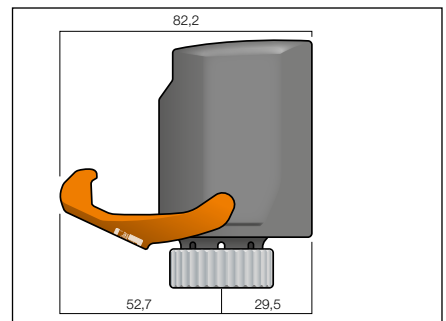
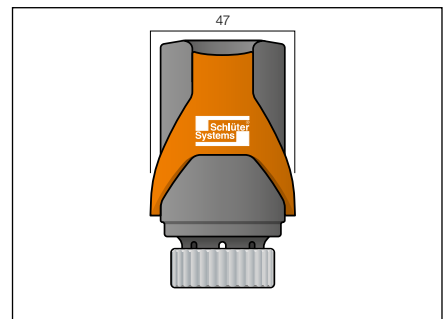

For further data and information, please refer to the installation or operating instructions



### Note:

The installation of string control valves or other adjustment features may be required depending on the hydronic properties of the distribution network. The EAHB adjusts the surface heating circuits of a distributor and is not suitable for the hydronic balancing of multiple heating circuit distributors or heating strings.

The function of adaptive hydronic balancing does not replace the heating capacity calculation required for rooms or buildings according to DIN EN 12831.



## Technical data – ESA actuator

TYPE	ESA 230 V, NC, M 30 x 1.5
Version	Normally closed
Valve connector	Union nut M 30 x 1.5
Voltage	230 V AC, 50 Hz
Max. output	2.0 W
Opening and closing time	≥ approx. 5 min
Actuating path	≥ 3.2 mm
Actuating force	90 N
Closed height	10.8 mm
First Open function	Re-open function (J)
Media temperature	10 to 60 °C (supply temperature limiting is activated in the Automatic position)
Storage temperature	-25 to 60 °C
Ambient temperature	0 to 50 °C
Protection rating/class	IP 54 / II
Installation position	Can be installed in any position
Connection cable	Flexible, grey, 1 m with ferrules

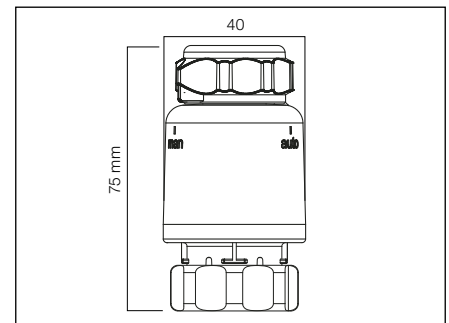

### Note:

The ESA actuator features a "First" and a "Re-open" function, which means it can be operated without current (for the start-up phase or during maintenance work).  
The visual function display show the operating status "Automatic".  
The actuator is normally closed in Automatic mode.



# Technical data – Room temperature control technology

## Functional diagram

- 1.1 ER/WL** Room sensors for heating/cooling - Wireless version



Schlüter control technology allows for individual, time-controlled room temperature management for heating and cooling. As part of a research project, the renowned Dresden Institute for Building Systems Engineering Research (ITG) reached the following conclusions in a comparison of the thin layer floor heating system Schlüter-BEKOTEC-THERM with conventional radiant floor heating systems: The use of efficient control technology and the quick response time of the BEKOTEC-THERM system can lead to additional **energy savings of up to 9.5 %**. In particular, this can be achieved with temperature reductions during night hours, which cannot be sufficiently implemented with standard radiant floor heating systems due to their large screed volume. Thanks to the quick responsiveness of BEKOTEC-THERM, the ceramic thermal comfort floor therefore meets the requirement of the German Buildings Energy Act (GEG) for highly controllable systems. Additional technical documentation about the individual control components is available online at [schluter.co.uk](http://schluter.co.uk).

- 1.2 ER** Room sensors for heating/cooling 5 V DC (SELV)  
Wired version  
Cable recommendation: J-Y (St) Y 2 x 2 x 0.6 mm (red, black, white, yellow - see note for 1.2)

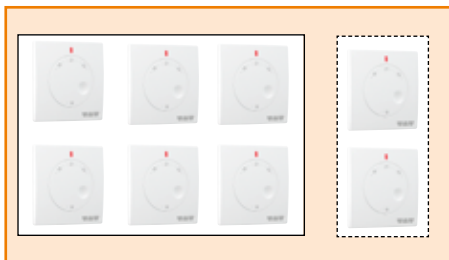

- 2.3 EAR WL** Connection module, wireless for 6 WL room sensors



- 2.4 EAR** Connection module wired for 6 room sensors



- 2.2 EET** Timer unit (optional)



- 2.1 EBC** Control base module



- 3 ESA/EAHB** Actuators 230 V

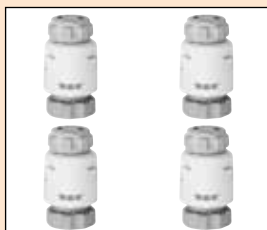

◀ **ESA – actuator** for static hydraulic balancing

▶ **EAHB – actuator** for adaptive hydraulic balancing

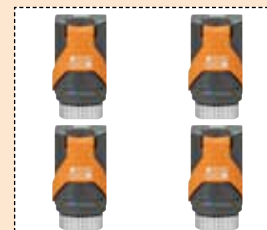

## Components of control technology

1

### Room sensors

The following two variants are available:

- Room sensor WL (wireless)
- Room sensor, DC 5 V (wired)

1.1

### ER/WL room sensor for heating/cooling WL Wireless

Room sensor, wireless version. Unrestricted, flexible use for building and structural technology. The wireless room sensor transmits the current room temperature and the set-point value to the room sensor connection module WL.

1.2

### ER Room sensor for heating/cooling

Room sensor, wired version. The wired version of room sensor transmits the current room temperature and the set-point value to the connection modules. *See note regarding cable installation!*

The module is operated with 5 V DC of safety extra-low voltage (SELV) via the base module in combination with the room sensor connection module.

The operating state "heating/cooling" is displayed by the "red/blue" colour change of a light-emitting diode (LED).

For both room sensor types, the temperature set-point is adjustable from 8 to 30 °C and can be restricted below the dial with set-point limiters. The time-controlled temperature reduction of 4 °C is effected by a timer unit at the base module.

#### Note:

Only cables with maximum wire cross-sections of 0.8 mm<sup>2</sup> may be connected to wired room sensors.

Cable recommendation:  
J-Y (St) Y 2 x 2 x 0.6 mm  
(red, black, white, yellow)

2.1

### EBC – Control base module

The base module is used for both wireless and/or wired connection modules, which makes it easy to implement mixed installations and upgrades.

The base module supplies the corresponding room sensors of the wired version with 5 V DC safety extra-low voltage (SELV) via the corresponding connection modules. The connected actuators are supplied with 230 V AC via the connection modules.

Additional functions:

- Slot for optional timer unit
- Pump circuit (relay) "Heating"
- Pump circuit (relay) "Cooling"
- Cascade output for connecting the heating/cooling output to additional base modules
- Input for "heating/cooling" switch

2.2

### ET Timer unit

The timer unit can be plugged directly into the base module after programming. This effects a temperature reduction of 4 °C during the night.

Functions:

- Time recording/programming: date, time weekdays (century calendar)
- Time recording/programming of temperature reduction
- Setting the deferred pump shut-down
- Setting the valve and pump protection function

2.3

### EAR/WL room sensor connection module, wireless

For assigning 2 or 6 wireless room sensors ER/WL. The connection modules EAR 2 WL for 2 or EAR 6 WL for 6 room sensors can be combined by simply plugging them together in order to adjust the number of rooms to be regulated or to adjust and expand the actuators/heating circuits to be assigned. The EBC base model supplies the voltage of 230 V for the actuators.

2.4

### EAR room sensor connection module

For connecting 2 or 6 ER room sensors. The connection modules EAR 2 for 2 or EAR 6 for 6 room sensors can be combined by simply plugging them together in order to adjust the number of rooms to be regulated or to adjust and expand the actuators/heating circuits to be assigned.

The voltage of 5 V DC (SELV) for the room sensors and 230 V for the actuators is supplied by the EBC base modules.

Wired and wireless modules can be combined.

3

### ESA/EAHB actuators 230 V

The ESA actuators typically regulate the flow at the individual cold leg valves of the heating circuit distributor based on thermostat settings. The static hydronic balancing occurs at the distributor.

The EAHB actuators for intelligent, adaptive hydronic balancing allow for optimum energy efficiency depending on the hot leg and cold leg temperature of the heating circuit.



2.3

### EAR/WL

Connection module, wireless for 2 WL room sensors



2.4

### EAR

Connection module wired for 2 room sensors

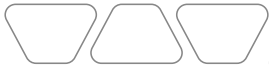

# Connecting the fixed-value control station (FRS)

## Power supply

### Power supply

The electrical cable for the water temperature control of the supply temperature is about 1 m long. A corresponding 230 V/50 Hz voltage supply must be set up in the distributor cabinet, either for in wall installation or in the area of the distributor.

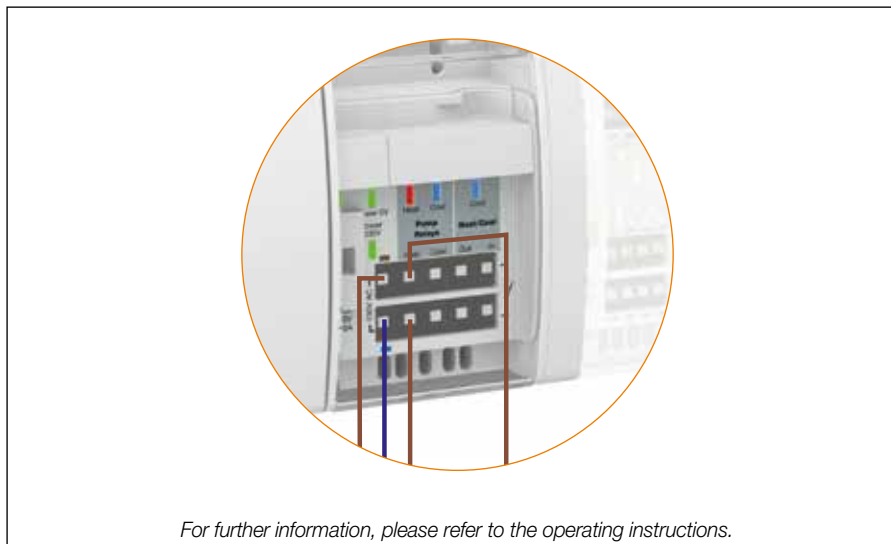
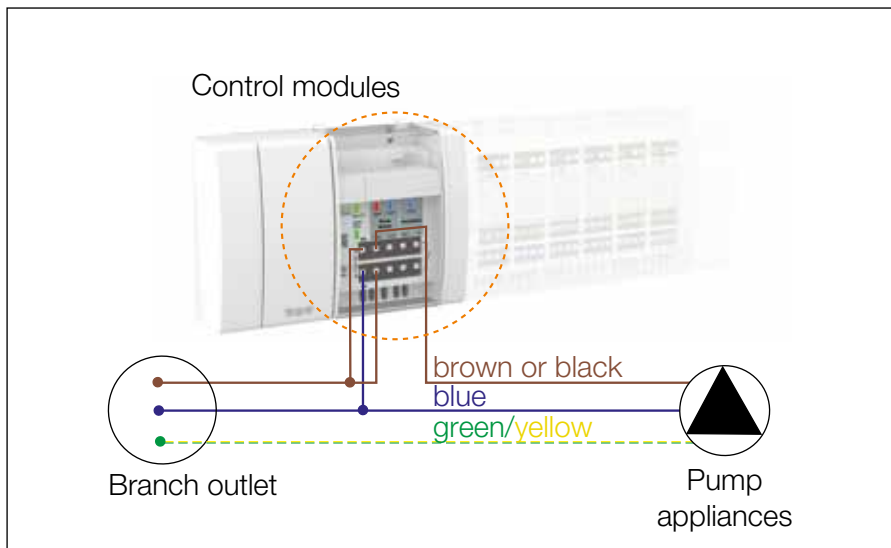

#### Note:

##### **A pump control/switch-off mechanism must be set up.**

The pump switch deactivates the pump of the fixed supply temperature control when all actuators at the heating circuit distributor are closed. This variation ensures the energy efficient operation of the water temperature control unit. We recommend using the Schlüter base module with pump switch.

## Connecting the cooling function of the control technology

Heat pumps have a so-called change-over valve. This valve generates a signal that can be used for switching between heating and cooling operation. The BEKOTEC-THERM controls are also able to process this signal. You can connect the change-over valve of the heat pump with the Schlüter-BEKOTEC-THERM EBC base module by using a two-core cable.

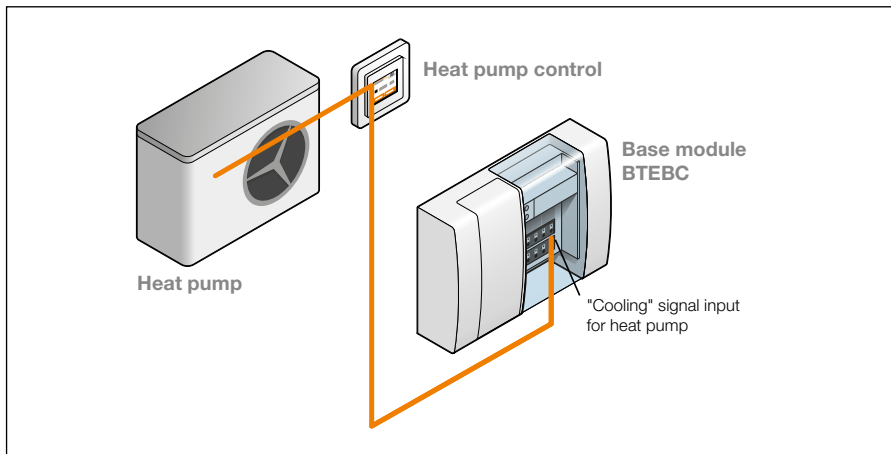

Once the signal is connected to the control, the effective direction of the actuators on the floor heating distributor changes. The actuators therefore open when the room temperature rises and enable cold water to flow through the floor circuits. The room temperature continues to be controlled via the BEKOTEC-THERM-ER/WL thermostats, which communicate with the BTEBC base module. That process cools the floor and removes heat from indoor spaces.





## Technical data – Return temperature limit valve RTB / RTBR

### General

Schlüter-BEKOTEC-THERM-RTB/-RTBR are return temperature limit valves for concealed wall mounted installation. They are used in cases where the required low system temperatures for a heating circuit of the Schlüter-BEKOTEC-THERM ceramic thermal comfort floor are not protected with suitable temperature limiters, mixing valves or the heating system.

They can be installed for the systematic temperature control of a secondary heating system for the floor.

The unit is installed in combination with a heating system, using a supply temperature of max. 65 °C. Prior to installation, a qualified expert must review the control technology and hydronic installations.



Schlüter®-BEKOTEC-THERM-RTB – Return temperature limit valve



Schlüter®-BEKOTEC-THERM-RTBR –  
Combined return temperature limit valve and room temperature control

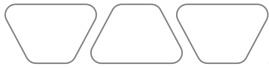

# Technical data – Return temperature limit valve RTB

## Function and installation

Schlüter-BEKOTEC-THERM-RTB limits the return temperature of a heating circuit.

It is operated in a room with an additional radiator. Select the installation position in such a way that the heating water first flows through the Schlüter-BEKOTEC-THERM heating circuit and then through the BEKOTEC-THERM-RTB return temperature limit valve. The heating medium cools down on its way from the floor surface to the return temperature limit valve. In this way, the floor temperature covers the basic heat requirements, while the radiator regulates the room temperature.

Depending on the temperature, the valve and sensor element in the thermostat **11** regulates and limits the flow through the BEKOTEC-THERM-RTB valve. The return temperature is set at the thermostat dial **7** and can be adjusted from +20 °C to +40 °C. Changing the dial settings regulates the floor surface temperature.

## Schlüter®-BEKOTEC-THERM-RTB

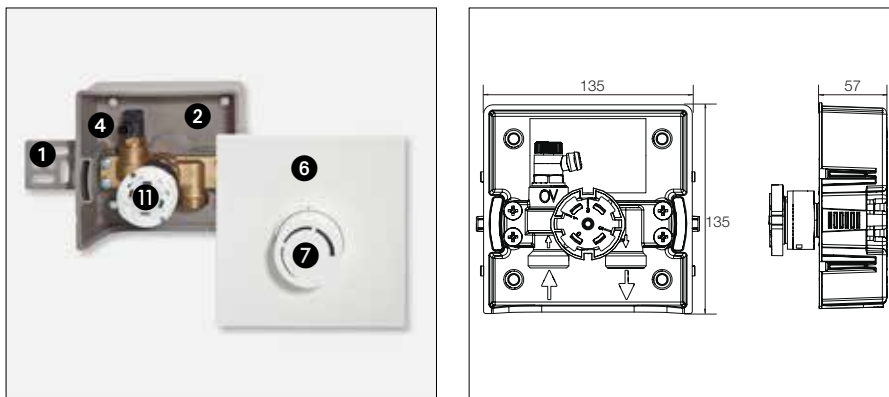

- 1 Attachment angle
- 2 Installation box
- 4 Flushing and venting valve
- 6 Front panel
- 7 Dial
- 11 Thermostat valve RTB (sensor element)

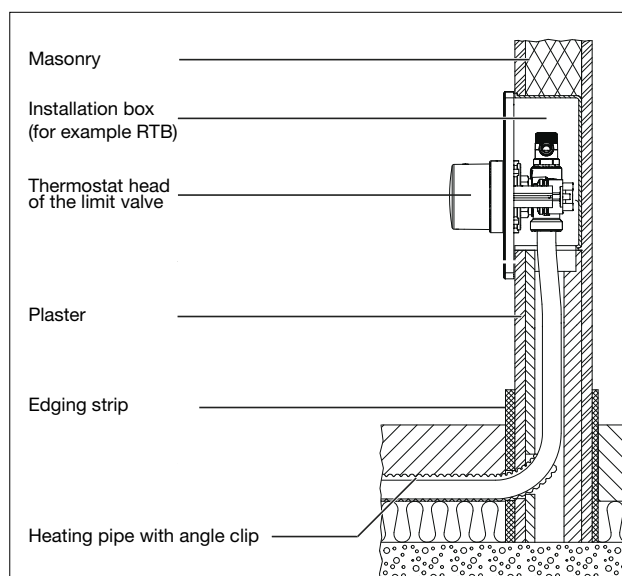

### Note:

Prior to installation, a qualified expert must review the control technology and hydronic installations. The installation and assembly instructions of the manufacturer must be observed. Please contact our Technical Department for further information.

# Technical data – Return temperature limit valve RTBR

## Function and installation

Schlüter-BEKOTEC-THERM-RTBR limits the return temperature of a heating circuit and regulates the room temperature.

It is operated in a room with a radiator. Installation in rooms without additional radiators is possible taking into account the required basic heat demand. Select the installation position in such a way that the heating water first flows through the Schlüter-BEKOTEC-THERM heating circuit and then through the BEKOTEC-THERM-RTBR room temperature control valve.

The heating medium cools down on its way from the floor surface to the RTBR.

The return temperature is pre-set at the RTBR valve dial (3) and can be adjusted from +20 °C to +40 °C.

The dial (7) of BEKOTEC-THERM-RTBR also features an integrated room sensor for precise adjustment of the desired room temperature from +7 °C to +28 °C. Changing the dial settings affects the floor surface temperature and, accordingly, the room temperature.

Schlüter-BEKOTEC-THERM-RTBES set comprises a return temperature limit valve with a closed front panel, a thermoelectric actuator ESA2 230V and a DITRA-HEAT-E controller. The actuator is mounted on the return temperature limit valve in the wall connection box. The Schlüter-DITRA-HEAT-E controller regulates the room temperature via the actuator and enables timed temperature control.



- 1 Attachment angle
- 2 Installation box
- 3 Return temperature limit valve
- 4 Flushing and venting valve
- 6 Front panel
- 7 Dial
- 8 Thermostatic set piston

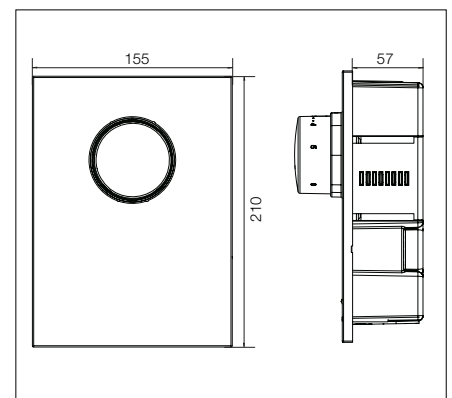

- 1 Attachment angle
- 2 Installation box
- 3 Return temperature limit valve
- 4 Flushing and venting valve
- 6 Front panel
- 12 ESA2 230 V
- 13 DITRA-HEAT-E controller

Connection diagram, see page 174.

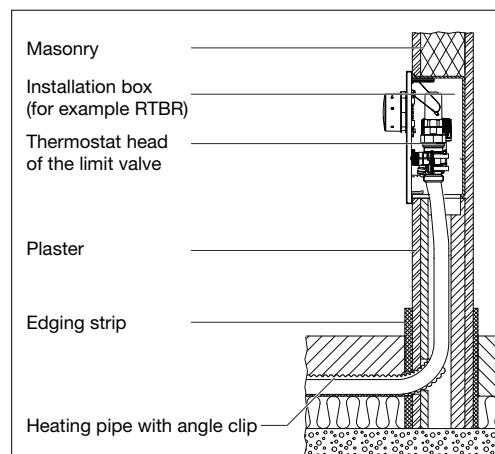
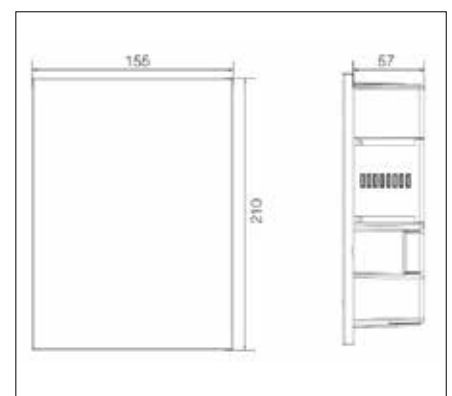

### Note:

Prior to installation, a qualified expert must review the control technology and hydronic installations. The installation and assembly instructions of the manufacturer must be observed. Please contact our Technical Department for further information.



# Technical data – Return temperature limit valve RTB / RTBR

## Installation

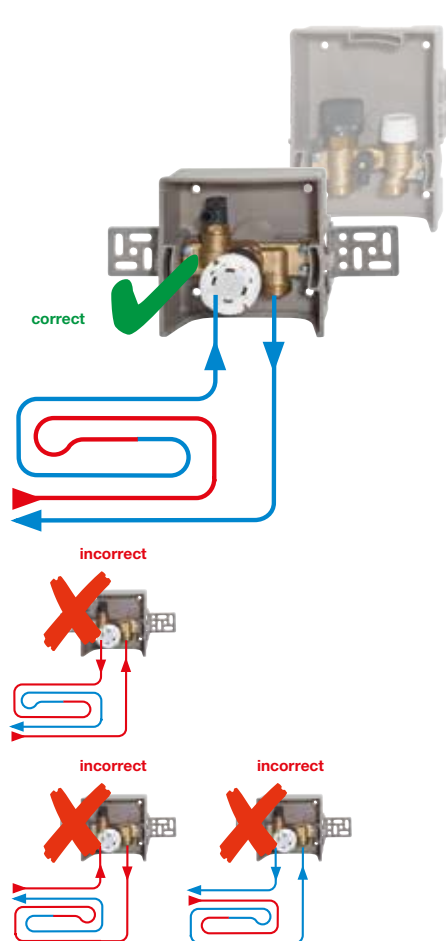

- Do not position the Schlüter-BEKOTEC-THERM-RTB/RTBR thermostat in direct sunlight or near to other heat sources e.g. radiators.
- The unit is installed at least 20 cm above the finished floor, measured from the bottom edge of the installation box, which is open on the underside. To measure the room temperature (RTBR) and ensure a comfortable operating height, we recommend installing the unit at a height of approx. 1.20 m or more. Align the front edge flush with the finished wall covering. Use the supplied installation angles to align and attach the installation box.
- Slide on the protective covering to keep the valve clean.
- The final attachment is made with plaster or mortar.
- Once the connection to the supply line has been made, the heating circuit must be installed in a coiled pattern (see page 38, 52, 62, 72, 87, 97 or 106).  
The self-sealing connection fitting BTZ 2 AN... or the connector angle BTZ 2 AW... with ½" external threading can be used for connecting the heating circuit to the supply and return line (use special valves and connectors for single pipe systems).
- The return temperature limit valve is connected at the end of the heating circuit, using the clamp attachments for Schlüter-BEKOTEC-THERM (art. no. BTZ2KV ...).
- In a next step, a direct connection from the valve to the return line of the dual pipe heating system is established.  
The self-sealing connection fitting BTZ 2 AN ... or the connector angle BTZ 2 AW ... with ½" external threading can be used for connecting the heating circuit to the supply and return line.
- The heating system is then filled and vented at the valve.
- The Schlüter-BEKOTEC-THERM ceramic thermal comfort floor is now ready to perform a pressure test according to the procedure on page 170.
- Set the white front panel in and align it.
- For information about settings and start up, see page 146.



### Connection elements:

Please refer to the current Schlüter-BEKOTEC-THERM illustrated price list for further information on the above-referenced connecting elements.

Integrating a heating circuit into a floor level distribution

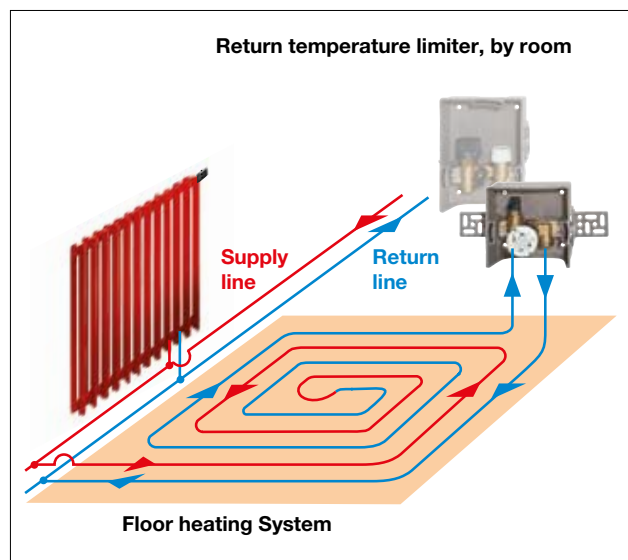

Integrating a heating circuit into a riser

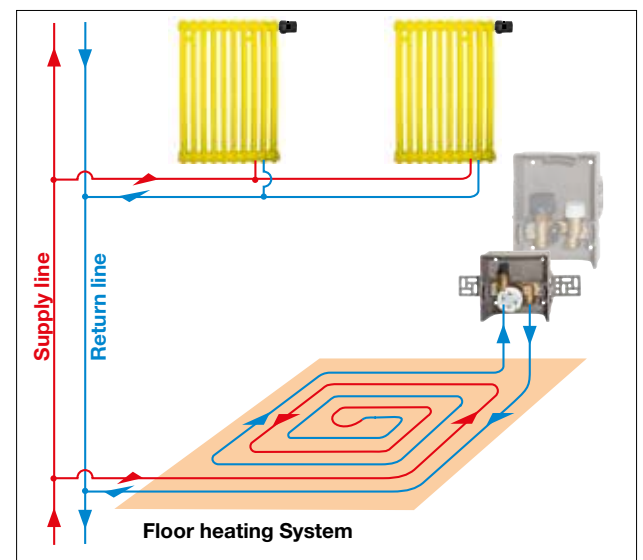

## Heating circuit lengths and output data

### ... in conjunction with the Schlüter-BEKOTEC-THERM-RTB/-RTBR return temperature limit valves

Approximate values for bathrooms with interior temperatures of **24 °C** and an average return temperature setting of approx. 35 °C, with a minimum supply temperature of **min. 50 °C**.

System pipe dimension	Installation spacing	Max. heating	Max. Heating area	Specific heat output*	Pressure loss incl. limit valve	Volume flow
mm	mm	m	m <sup>2</sup>	W/m <sup>2</sup>	mbar	kg/h
16 x 2 mm for BEKOTEC-EN/P, BEKOTEC-EN/PF, BEKOTEC-EN 23 FI 30 and BEKOTEC-EN 23 F PS	75	90	6.5	95	40	45
	150	90	12.0	80	65	55
14 x 2 mm for BEKOTEC-EN 23 FI 30, BEKOTEC-EN 23 F PS and BEKOTEC-EN 23 F	75	80	5.5	95	65	41
	150	80	11.0	80	85	50
12 x 1.5 mm for BEKOTEC-EN 18 FTS	100	60	5.5	90	70	30
	150	60	8.5	80	85	36
10 x 1.3 mm for BEKOTEC-EN 12 FK and EN 12 F PS	100	55	5.0	90	60	49
	150	55	7.5	80	85	31

\* Output data apply to ceramic surface coverings.

Please refer to the diagrams of the respective studded system panels for additional performance data of the Schlüter-BEKOTEC-THERM systems.

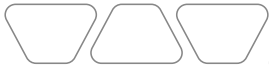

## Special solutions

### Integrating a heating circuit into a single pipe heating system

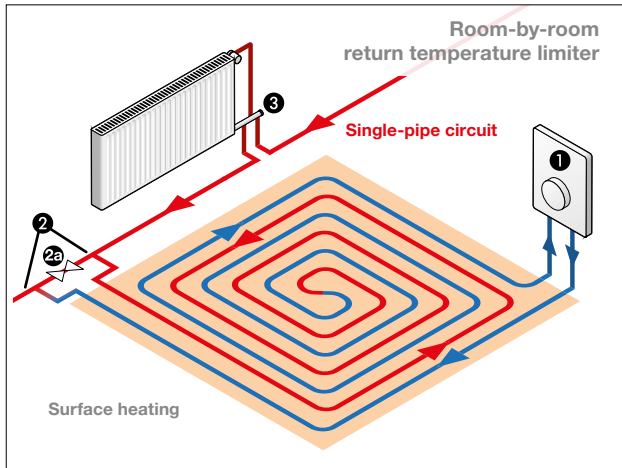

#### Installation in single pipe heating systems

Select the installation location in such a way that part of the heating water flows through the BEKOTEC heating circuit and another through controllable transfer sections (2) in the existing single pipe circuit. The return temperature limit valve (1) must be positioned in such a way that the heating water first flows through the heating circuit and then through the RTB/RTBR valve.

The heating circuit return line is connected after the transfer section.

The transfer section (2) must have at least the same pipe diameter as the existing single pipe circuit and must be equipped with a controllable valve (2a) (return screw/ string control valve).

The volume flow can be controlled with the settings of the limit valve (2a) in accordance with the hydronic conditions.

Adjustable single pipe valves (3) should also be installed at the radiators.

As a general rule, the hydronic conditions of the single pipe system must be reviewed for this application.

### Connecting two heating circuits to a return temperature limit valve

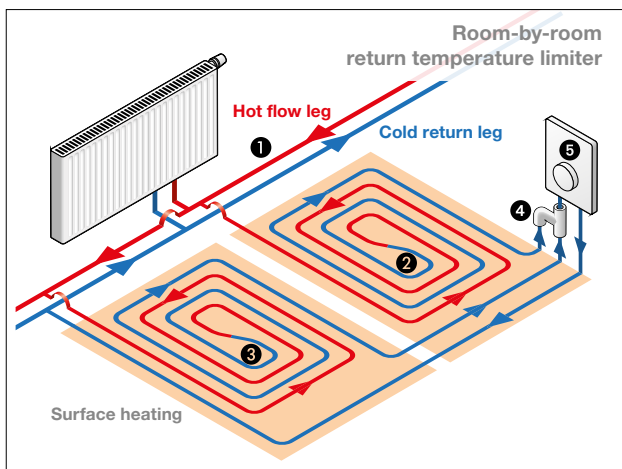

The BEKOTEC-THERM-DA connector (4) allows for connecting **two heating circuits of equal size** to a single return temperature limit valve.

To this end, two heating circuits (2 3) of the same size are installed on the structure side of the supply line (1) and connected with the connector (4). The connector (4) is attached directly to the supply line of the return temperature limit valve (5).

Max. length of heating circuits

Heating pipe Ø 16 mm = 80 m

Heating pipe Ø 14 mm = 70 m

Heating pipe Ø 12 mm = 60 m

Heating pipe Ø 10 mm = 50 m





## Floor heating for single heating circuits

### Setting and start up – RTB/RTBR

#### Start up

The Schlüter-BEKOTEC-THERM ceramic thermal comfort floor is ready for cure heating only 7 days after the installation of the floor covering. Please observe the instructions of data sheets 9.1 to 9.8, Schlüter-BEKOTEC. Start with a supply temperature of 20 °C and increase it by 5 °C a day to a maximum supply temperature of 35 °C. Close the return temperature limit valves with protective caps to ensure that no heating can take place during the installation of the screed and surface covering.

Further information on installing various floor coverings can be found *from page 148*.

#### Setting

The tables below show the temperature settings at the thermostat heads of Schlüter-BEKOTEC-THERM-RTB and -RTBR.

#### Return temperature setting, RTB

Temperature setting at thermostat head RTB	
RTB (triple scaling)	Return temperature
Scale 1	0 - 15 °C
Scale 2	15 - 35 °C
Scale 3	35 - 50 °C

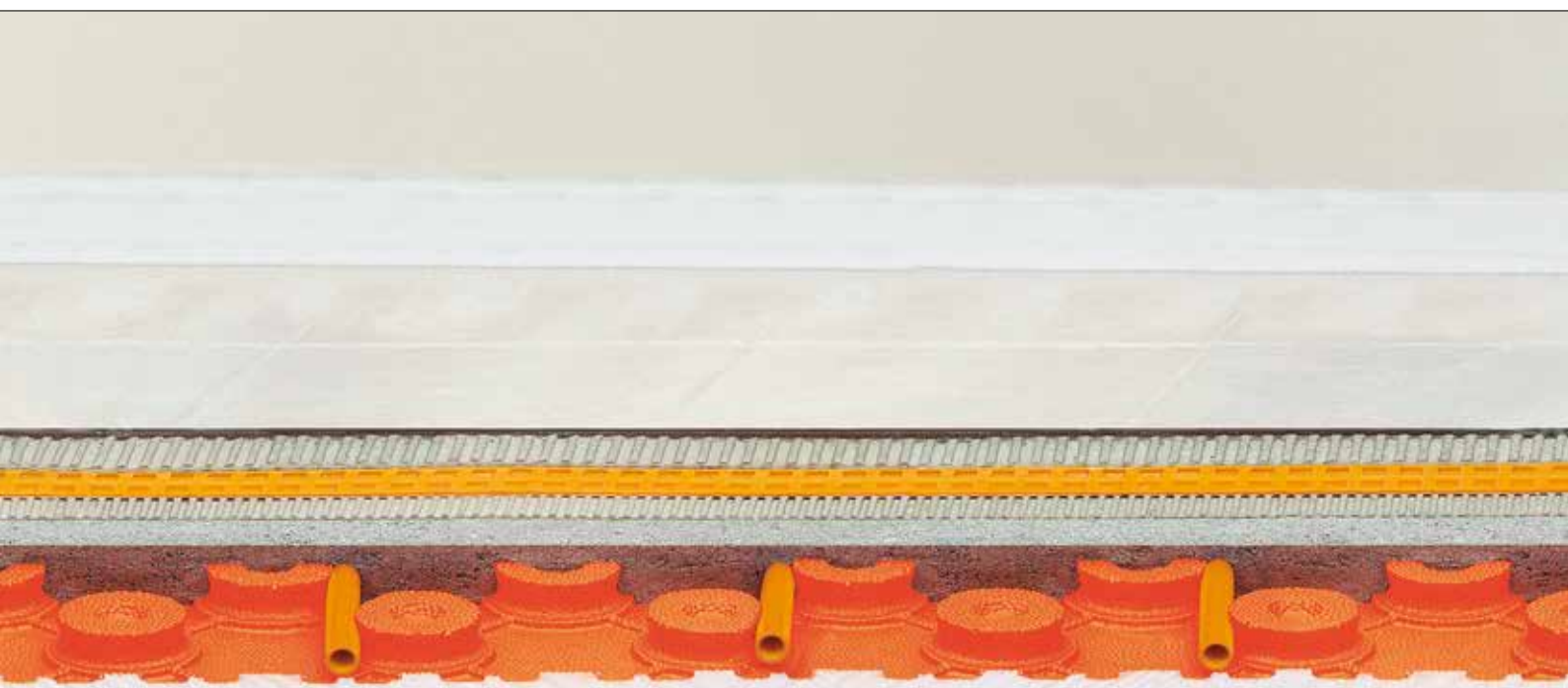
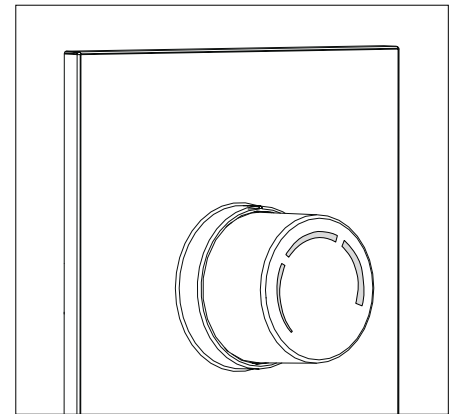

# Floor heating for single heating circuits

RTBR setting

Return temperature setting, RTBR

Temperature setting at the RTBR dial	
Scale	Return temperature
Position number	Temperature
0	Valve completely closed
10	10 °C
20	20 °C
25	25 °C
30	30 °C
35	35 °C
40	40 °C
-	Valve completely opened until a temperature of approx. 43 °C has been reached

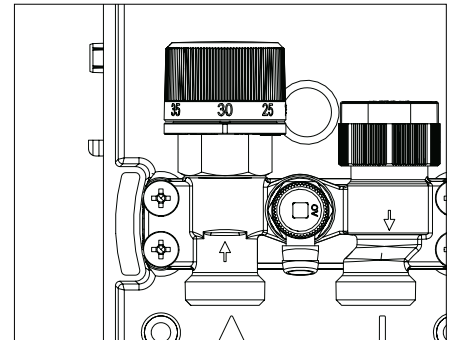

Setting the room temperature at the RTBR valve

Temperature setting at thermostat head RTBR	
RTBR	Room temperature
0	Valve completely closed
*	7 °C (frost protection setting)
1	12 °C
2	16 °C
3	20 °C
4	24 °C
5	28 °C

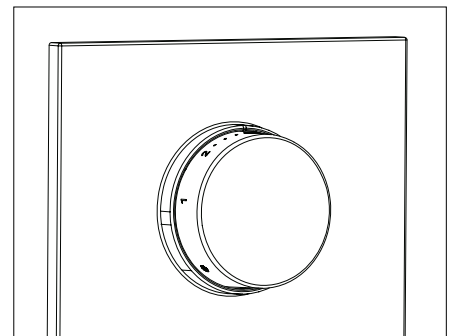



# Installation notes and system start up for various floor coverings

## Ceramic tile and natural stone coverings



The Schlüter uncoupling mat can be installed in accordance with the installation instructions of product data sheets 6.1 (DITRA), 6.2 (DITRA-DRAIN 4), 6.4 (DITRA-HEAT), 6.5 (DITRA-HEAT-PS) or 6.7 (DITRA-PS) as soon as the screed is ready to bear weight. Gypsum based screeds can be covered as soon as they have reached a residual moisture level of 2 CM % or less.

## Non ceramic floor coverings

All manufacturer specifications as well as standards and regulations must be followed.

In principle, the floor coverings described in the following sections are suitable for floor heating systems. Exceptions include screeds with finished surfaces. Please contact our Technical Department in case of filler compounds or thin layer screed coating systems, which are installed as a bonded assembly with the screed.

However, the area thermal insulation of the floor covering  $R$  [ $m^2K/W$ ] should be as low as possible and not exceed a value of  $R = 0.15 m^2 K/W$ .

Floor coverings with a high area thermal insulation require significantly higher operating temperatures with the same spacing of heating pipes and the same heat output (heat flow density).

Especially in the case of non ceramic coverings, high operating temperatures caused by larger thermal resistance increase the heat loss to unheated underlying areas, which adjoin soil or the outdoors.

It is frequently unknown at the time of architectural design which floor coverings will be used. In such cases, an average thermal resistance of  $R = 0.10 m^2 K/W$  should be assumed according to DIN EN 1264 (BS EN 1264).

The corresponding heat output and operating temperatures for the various floor coverings can be found in the corresponding heat output tables and the performance diagrams of the selected studded screed panel in this handbook.

Please note the application areas as shown on (page 25) as well as the specifications of the flooring manufacturer.

### Carpet, PVC, vinyl, linoleum

Check prior to installation whether the heated screed needs to be sealed according to DIN 18365, "Flooring work." Floor coverings must bear the seal "Suitable for floor heating systems" or be approved for floor heating systems by their manufacturer. If using carpet, choose a variety with a low area thermal insulation value. Coverings with higher area thermal insulation values frequently require a higher operating temperature for the floor heating system.

- Adhesives must be suitable for floor heating systems as well as for the surface covering and the screed base.
- The residual moisture requirements for the screed must be observed (see page 150).



### Note:

Schlüter uncoupling mats must be used for the installation of ceramic tile and natural stone coverings. Their assembly height of approx. 5 - 7 mm is to be considered in the assembly calculations. All other covering materials are generally installed directly (observe manufacturer instructions!) over the BEKOTEC screed without uncoupling mats. Keep in the installation height and final height of the corresponding uncoupling mat in mind when calculating the height of the screed with regard to **adjoining areas** with tile coverings. In addition to the applicable installation guidelines, note the permissible residual moisture content of the screed for the selected covering material.

*For further information, see pages 25, 32, and 148.*

# Installation notes and system start up for various floor coverings

## Non ceramic floor coverings

### Parquet

Observe all manufacturer specifications when installing parquet over the Schlüter-BEKOTEC-THERM system. Consult the manufacturer and the installer about the suitability of specific parquet types and their components on a floor heating system.

#### The following requirements must be observed:

- The moisture content of the wood must meet the requirements of the manufacturer.
- Adhesives must be suitable for floor heating systems as well as for the surface covering and the screed base.
- If the manufacturer specifies any restrictions for the surface temperatures, suitable technical measures must be taken to comply.
- The residual moisture requirements for the screed must be observed (*see page 150*).

### Floating parquets, laminates, cork, vinyl and linoleum on support materials

Floating coatings with additional insulation between the covering and the screed increase the area thermal insulation of the floor covering. Coverings with higher area thermal insulation values frequently require a higher operating temperature for the floor heating system.

- Ask the flooring manufacturer for alternative separating layers with lower thermal resistance.
- The covering with the separating layer should not exceed a total thermal resistance of  $R = 0.15 \text{ m}^2 \text{ K/W}$ .
- Permanent attachment on the screed is preferable over floating installation. The manufacturer of the covering must approve the attachment to the corresponding components.
- The residual moisture requirements for the screed must be observed (*see page 150*).



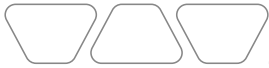

# Installation notes and system start up for various floor coverings

No functional heating required according to DIN EN 1264

Contrary to the specifications of BS EN 1264, no functional heating is required for the BEKOTEC-THERM screed, since the tensions in the screed are confined to small modules within the studded BEKOTEC screed panel. Whatever the screed, however, we recommend a hydraulic functional check of the newly installed system.

## Heating up screeds with ceramic coverings

The Schlüter-BEKOTEC-THERM ceramic thermal comfort floor is ready for heating only 7 days after the installation of the floor covering. Please observe the instructions of the corresponding *BEKOTEC data sheets 9.1 - 9.8*. Increase the supply temperature by a maximum of 5 °C a day to reach the required design temperature, starting from 25 °C water temperature.

## Heating up and curing heating screeds with non ceramic coverings

The Schlüter-BEKOTEC-THERM assembly without Schlüter uncoupling mats is ready for start-up and cure heating when the screed has reached a sufficient hardness.

Weather conditions are a crucial, but often overlooked factor in the drying and curing process of the screed. The reduced screed thickness of the BEKOTEC screed is an advantage and shortens the drying time.

The screed can be heated after 7 days. All manufacturer specifications must be met.

The supply temperature is increased by  $\leq 5$  °C a day to a maximum of 35 °C, starting from 25 °C. This temperature is then maintained until the screed is fully cured.

CM measurements and surface installations can only be performed when the system is cold.

### Installation readiness- residual screed moisture

Cure heating is intended to dry the screed prior to installing moisture sensitive **non** ceramic floor coverings.

Establish measuring locations in the screed that do not contain heating pipes at a spacing of 10 cm and mark them. The floor installer will determine the residual moisture of the screed with the CM device directly prior to installing the floor covering.

In addition to the applicable installation guidelines, note the permissible residual moisture level of the screed for the selected covering material.

The table below indicates the customary, maximum permissible moisture content for screeds.

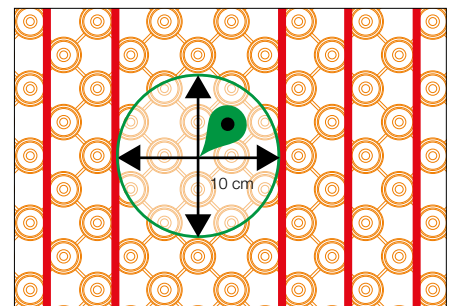

Floor covering	Residual moisture	
	Cement screed	Gypsum based screed
Textile floor coverings*	$\leq 1.80$ %	$\leq 0.50$ %
Resilient floor coverings* e.g. vinyl, PVC, rubber, linoleum		
Parquet, cork, laminate*		

\* Please observe the installation guidelines of the flooring manufacturer with regard to residual moisture in the screed. **Note:** Certificate forms for heat curing can be found in Attachment V and VI.

### Areas with non ceramic coverings must be protected from moisture.

The uncoupling mat Schlüter-DITRA **for ceramic coverings** can be installed in accordance with the manufacturer's recommendations of product *data sheets 6.1, 6.2, 6.4, 6.5 or 6.7* as soon as the moist screed is ready to bear weight.

Areas with moisture sensitive covering materials that adjoin ceramic coverings over a DITRA uncoupling mat must be protected from permeating moisture.

## Product service and planning materials

Heat insulation of radiant panel heating systems in accordance with the German Buildings Energy Act (GEG)

The German Buildings Energy Act (GEG) has given designers and architects more freedom in the design of the required heat insulation of the external envelope of buildings.

The main objective of the law is to limit the annual primary energy need. This is also reflected in the system technology of buildings.

Comprehensive calculation programs are available to determine annual primary energy needs. The energy needs certificate created on the basis of these calculations includes the necessary information to determine insulation needs.

### Conclusion

It is no longer possible to use fixed insulation layers for compliance with the German Buildings Energy Act (GEG). Floor heating systems do not have a fixed heat transfer coefficient (U value). The GEG only requires a minimum heat insulation in accordance with current standards.

**If the designer bases the calculations for the energy certificate of a building on better (lower) U values, these must be maintained for the insulation.**

The designer will enter the requirements for the actual insulation values in the Energy Pass, which must be created for every new building. The Energy Pass is to be handed to the designer of the heating technology or the contractor at the earliest possible time to select the most suitable insulation materials.

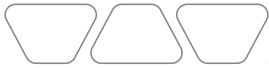

## Product service and planning materials

Heat insulation of a warm water floor heating system according to DIN EN 1264-4 (BS EN 1264-4)

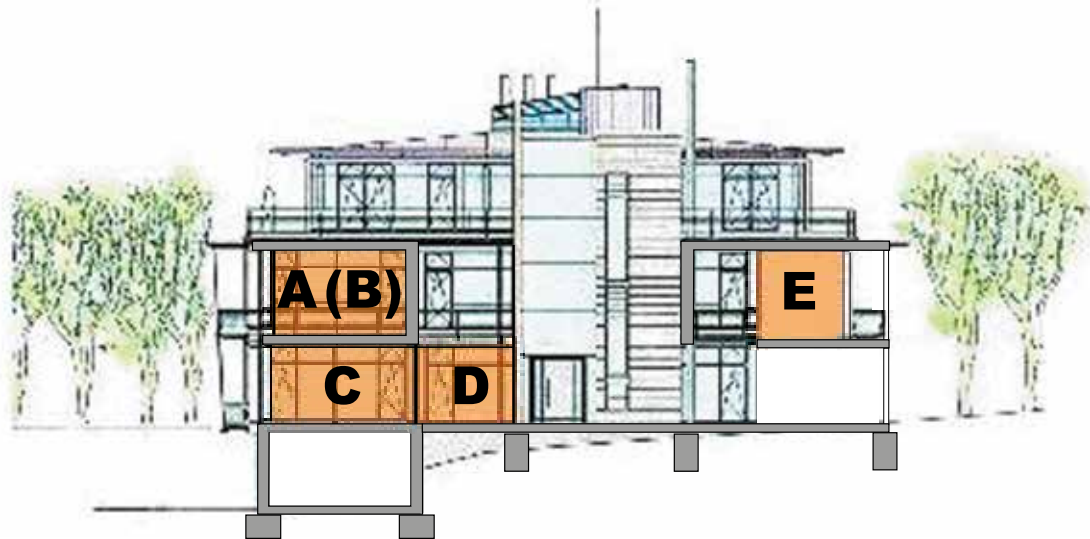

Minimum insulation values according to DIN EN 1264-4 (BS EN 1264-4)		Underlying outside temperature Td			
		Unheated or occasionally heated underlying room or rooms with soil contact*	Outside temperature used for design Td ≥ 0 °C	Outside temperature used for design 0 °C > Td ≥ -5 °C	Outside temperature used for design -5 °C > Td ≥ -15 °C
Room areas	A	B, C, D	E	E	E
Thermal resistance R <sub>λ</sub> [m <sup>2</sup> K/W]	0.75	1.25	1.25	1.50	2.00

\* These minimum values should be increased if the subsoil water level is ≤ 5 meter.

### Note

The insulation values (U values) used by designers for calculations determine the thickness of insulation layers in unheated rooms or rooms that directly adjoin the soil.

These values typically exceed the minimum insulation listed in the table according to DIN EN 1264-4 (BS EN 1264-4).

#### A Underlying heated room

General requirements:

R<sub>ins</sub> of at least 0.75 m<sup>2</sup> K/W  
U<sub>ins</sub> of at least 1.33 W/(m<sup>2</sup> K)

#### B, C, D Ceiling adjoining unheated room and soil

For installing a heated floor system in a new house with normal inside temperatures over ceilings that adjoin unheated or occasionally heated underlying rooms or are in direct contact with the soil, the following thermal resistance or U value must be selected:

R<sub>ins</sub> of at least 1.25 m<sup>2</sup> K/W  
U<sub>ins</sub> of at least 0.80 W/(m<sup>2</sup> K)

#### E Ceilings adjoining outside air

Additionally, the following thermal resistance or U value must be selected for ceilings that adjoin outside air, with temperatures from -5 °C to -15 °C:

R<sub>ins</sub> of at least 2.00 m<sup>2</sup> K/W  
U<sub>ins</sub> of at least 0.50 W/(m<sup>2</sup> K)

# Floor assemblies for various application areas – ceramic thermal comfort floor

## C, D, E

Sample assemblies adjoining unheated rooms and soil

- Without sound insulation requirements

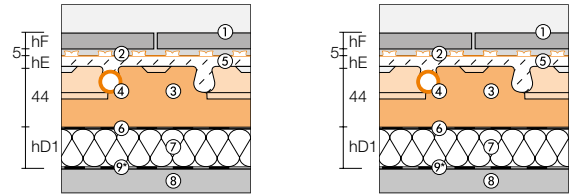

Total thermal resistance		R = 2.106 (m <sup>2</sup> K)/W				R = 2.006 (m <sup>2</sup> K)/W		
U value total		U = 0.475 W/(m <sup>2</sup> K)				U = 0.498 W/(m <sup>2</sup> K)		
	Position no./ (description)	Layer thickness S	Thermal conductivity λR	Thermal resistance s/λR	Layer thickness S	Thermal conductivity λR	Thermal resistance s/λR	
		mm	W/(m K)	(m <sup>2</sup> K)/W	mm	W/(m K)	(m <sup>2</sup> K)/W	
Ceramic covering, thin bed installation	① (hF)							
Schlüter-DITRA , thin bed installation	②	5			5			
Screed coverage	⑤ (hE)	8			8			
BEKOTEC studded panel (height of studs)	③	24			24			
BEKOTEC studded panel/ floor thickness 20 mm EPS 033 DEO	③	20	0.033	0.606	20	0.033	0.606	
hD1 additional insulation with EPS 040 DEO	⑦ (hD1)	60	0.040	1.500	–	–	–	
hD1 additional insulation with PUR 025 DEO	⑦ (hD1)	–	–	–	35	0.025	1.400	
hD2 additional insulation with EPS 040 DEO	⑦ (hD2)	–	–	–	–	–	–	
hD2 additional insulation with PUR 025 DEO	⑦ (hD2)	–	–	–	–	–	–	
<b>Assembly height without surface covering</b>		<b>117</b>			<b>92</b>			

## C, D, E

Sample assemblies adjoining unheated rooms and soil

- Without sound insulation requirements
- With increased heat insulation:

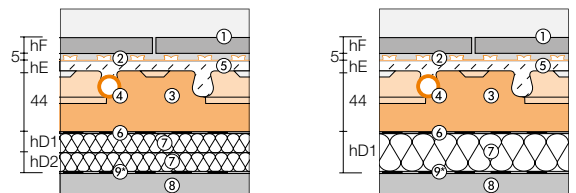

Total thermal resistance		R = 2.981 (m <sup>2</sup> K)/W				R = 3.006 (m <sup>2</sup> K)/W		
U value total		U = 0.335 W/(m <sup>2</sup> K)				U = 0.333 W/(m <sup>2</sup> K)		
	Position no./ (description)	Layer thickness S	Thermal conductivity λR	Thermal resistance s/λR	Layer thickness S	Thermal conductivity λR	Thermal resistance s/λR	
		mm	W/(m K)	(m <sup>2</sup> K)/W	mm	W/(m K)	(m <sup>2</sup> K)/W	
Ceramic covering, thin bed installation	① (hF)							
Schlüter-DITRA , thin bed installation	②	5			5			
Screed coverage	⑤ (hE)	8			8			
BEKOTEC studded panel (height of studs)	③	24			24			
BEKOTEC studded panel/ floor thickness 20 mm EPS 033 DEO	③	20	0.033	0.606	20	0.033	0.606	
hD1 additional insulation with EPS 040 DEO	⑦ (hD1)	50	0.040	1.250	–	–	–	
hD1 additional insulation with PUR 025 DEO	⑦ (hD1)	–	–	–	60	0.025	2.400	
hD2 additional insulation with EPS 040 DEO	⑦ (hD2)	45	0.040	1.125	–	–	–	
hD2 additional insulation with PUR 025 DEO	⑦ (hD2)	–	–	–	–	–	–	
<b>Assembly height without surface covering</b>		<b>152</b>			<b>117</b>			

### Further drawing numbers

④ Heating pipe – ⑥ PE foil (recommended if using flowing screeds) – ⑧ Load bearing substrate – ⑨\* Waterproofing (if required)

**Comments:** These assemblies exceed the minimum requirements for insulating layers according to DIN EN 1264 (BS EN 1264)  $U \leq 0.8 \text{ W}/(\text{m}^2\text{K})$  for rooms adjoining soil or unheated spaces. The supplementary specification of the German Institute for Construction Technology DIBt for  $U \leq 0.50 \text{ W}/(\text{m}^2\text{K})$  is met.

**Note:** Planners must always check whether any further requirements of the GEG have to be met.

Traffic load specifications for various objects must be taken into account when selecting insulating materials!

**The architect also has to specify the required waterproofing assemblies, especially in the case of construction segments adjoining soil to prevent floor moisture.**



# Floor assemblies for various application areas – ceramic thermal comfort floor

## C, D, E

Sample assemblies adjoining unheated rooms and soil

- With sound insulation requirements:

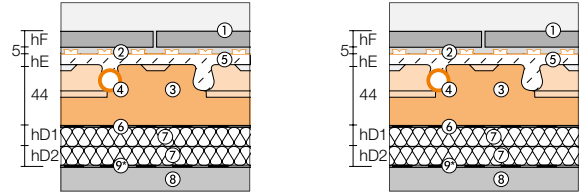

Total thermal resistance		R = 2.023 (m <sup>2</sup> K)/W				R = 2.050 (m <sup>2</sup> K)/W		
U value total		U = 0.494 W/(m <sup>2</sup> K)				U = 0.487 W/(m <sup>2</sup> K)		
	Position no./ (description)	Layer thickness S	Thermal conductivity λR	Thermal resistance s/λR	Layer thickness S	Thermal conductivity λR	Thermal resistance s/λR	
		mm	W/(mK)	(m <sup>2</sup> K)/W	mm	W/(mK)	(m <sup>2</sup> K)/W	
Ceramic covering, thin bed installation	① (hF)							
Schlüter-DITRA , thin bed installation	②	5			5			
Screed coverage	⑤ (hE)	8			8			
BEKOTEC studded panel (height of studs)	③	24			24			
BEKOTEC studded panel/ floor thickness 20 mm EPS 033 DEO	③	20	0.033	0.606	20	0.033	0.606	
hD1 additional insulation with EPS 040 DEO	⑦ (hD1)	30	0.040	0.750	–	–	–	
hD1 additional insulation with PUR 025 DEO	⑦ (hD1)	–	–	–	25	0.025	1.000	
hD2 additional insulation with EPS 045 DES (impact sound insulation)	⑦ (hD2)	30	0.045	0.667	20	0.045	0.444	
<b>Assembly height without surface covering</b>		<b>117</b>			<b>102</b>			

## C, D, E

Sample assemblies adjoining unheated rooms and soil

- With sound insulation requirements:
- With increased heat insulation:

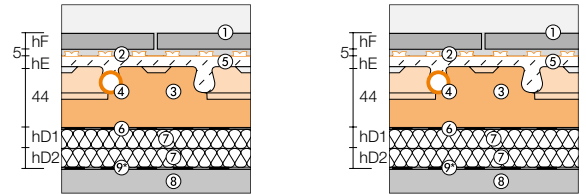

Total thermal resistance		R = 2.884 (m <sup>2</sup> K)/W				R = 3.050 (m <sup>2</sup> K)/W		
U value total		U = 0.346 W/(m <sup>2</sup> K)				U = 0.328 W/(m <sup>2</sup> K)		
	Position no./ (description)	Layer thickness S	Thermal conductivity λR	Thermal resistance s/λR	Layer thickness S	Thermal conductivity λR	Thermal resistance s/λR	
		mm	W/(mK)	(m <sup>2</sup> K)/W	mm	W/(mK)	(m <sup>2</sup> K)/W	
Ceramic covering, thin bed installation	① (hF)							
Schlüter-DITRA , thin bed installation	②	5			5			
Screed coverage	⑤ (hE)	8			8			
BEKOTEC studded panel (height of studs)	③	24			24			
BEKOTEC studded panel/ floor thickness 20 mm EPS 033 DEO	③	20	0.033	0.606	20	0.033	0.606	
hD1 additional insulation with EPS 040 DEO	⑦ (hD1)	60	0.040	1.500	–	–	–	
hD1 additional insulation with PUR 025 DEO	⑦ (hD1)	–	–	–	50	0.025	2.000	
hD2 additional insulation with EPS 045 DES (impact sound insulation)	⑦ (hD2)	35	0.045	0.778	20	0.045	0.444	
<b>Assembly height without surface covering</b>		<b>152</b>			<b>127</b>			

### Further drawing numbers

④ Heating pipe – ⑥ PE foil (recommended if using flowing screeds) – ⑧ Load bearing substrate – ⑨\* Waterproofing (if required)

**Comments:** These assemblies exceed the minimum requirements for insulating layers according to DIN EN 1264 (BS EN 1264)  $U \leq 0.8 \text{ W/(m}^2\text{K)}$  for rooms adjoining soil or unheated spaces. The supplementary specification of the German Institute for Construction Technology DIBt for  $U \leq 0.50 \text{ W/(m}^2\text{K)}$  is met. Only one layer of sound insulation is permissible, with a maximum compressibility  $\leq 3 \text{ mm}$  (CP 3). The requirements for slab ceilings according to DIN 4109 or design specifications must be observed for sound insulation.

**Note:** Planners must always check whether any further requirements of the GEG have to be met. Traffic load specifications for various objects must be taken into account when selecting insulating materials!

**The architect also has to specify the required waterproofing assemblies, especially in the case of construction segments adjoining soil to prevent floor moisture.**

## Floor assemblies for various application areas – ceramic thermal comfort floor

### A

#### Sample assembly adjoining other heated rooms

##### • With sound insulation requirements:

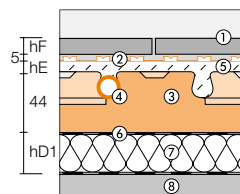

Total thermal resistance		R = 1.050 (m <sup>2</sup> K)/W		
U value total		U = 0.952 W/(m <sup>2</sup> K)		
	Position no./ (description)	Layer thickness S	Thermal conduc- tivity λR	Thermal resistance s/λR
		mm	W/(mK)	(m <sup>2</sup> K)/W
Ceramic covering, thin bed installation	① (hF)			
Schlüter-DITRA , thin bed installation	②	5		
Screed coverage	⑤ (hE)	8		
BEKOTEC studded panel (height of studs)	③	24		
BEKOTEC studded panel/ floor thickness 20 mm EPS 033 DEO	③	20	0.033	0.606
hD1 additional insulation with EPS 045 DES (impact sound insulation)	⑦ (hD1)	20	0.045	0.444
<b>Assembly height without surface covering</b>		<b>77</b>		

### B

#### Sample assembly adjoining other rooms with different heating (e.g. commercial properties)

##### • With sound insulation requirements:

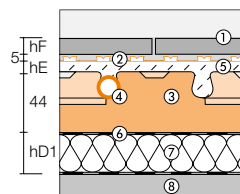

Total thermal resistance		R = 1.273 (m <sup>2</sup> K)/W		
U value total		U = 0.786 W/(m <sup>2</sup> K)		
	Position no./ (description)	Layer thickness S	Thermal conduc- tivity λR	Thermal resistance s/λR
		mm	W/(mK)	(m <sup>2</sup> K)/W
Ceramic covering, thin bed installation	① (hF)			
Schlüter-DITRA , thin bed installation	②	5		
Screed coverage	⑤ (hE)	8		
BEKOTEC studded panel (height of studs)	③	24		
BEKOTEC studded panel/ floor thickness 20 mm EPS 033 DEO	③	20	0.033	0.606
hD1 additional insulation with EPS 045 DES (impact sound insulation)	⑦ (hD1)	30	0.045	0.667
<b>Assembly height without surface covering</b>		<b>87</b>		

#### Further drawing numbers

④ Heating pipe – ⑥ PE foil (recommended if using flowing screeds) – ⑧ Load bearing substrate

**Comments:** The requirements for slab ceilings according to DIN 4109 or design specifications must be observed for sound insulation. Only one layer of sound insulation is permissible, with a maximum compressibility ≤ 3 mm (CP 3). Traffic load specifications for various objects must be taken into account when selecting insulating materials

**The architect must specify the required waterproofing.**

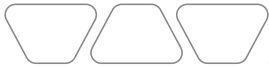

## Floor assemblies for various application areas – ceramic thermal comfort floor

### Sample assembly for renovation projects

#### • Without sufficient assembly height:

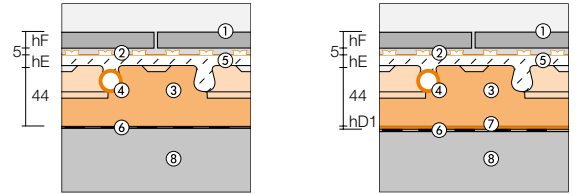

Total thermal resistance		R = 0.606 (m <sup>2</sup> K)/W			R = 0.717 (m <sup>2</sup> K)/W		
U value total		U = 1.650 W/(m <sup>2</sup> K)			U = 1.395 W/(m <sup>2</sup> K)		
	Position no./ (description)	Layer thickness S	Thermal conductivity λR	Thermal resistance s/λR	Layer thickness S	Thermal conductivity λR	Thermal resistance s/λR
		mm	W/(mK)	(m <sup>2</sup> K)/W	mm	W/(mK)	(m <sup>2</sup> K)/W
Ceramic covering, thin bed installation							
	① (hF)						
	Schlüter-DITRA , thin bed installation	5			5		
	②						
	Screed coverage	8			8		
	⑤ (hE)						
	BEKOTEC studded screed panel (stud height)	24			24		
	③						
	BEKOTEC studded screed panel/ base thickness 20 mm EPS 033 DEO	20	0.033	0.606	20	0.033	0.606
	③						
	hD1 Schlüter-BEKOTEC-BTS (impact sound improvement)*	–	–	–	5	0.045	0.111
	⑦ (hD1)						
<b>Assembly height without surface covering</b>		<b>57</b>			<b>62</b>		

\* **Tip:** Use Schlüter-BEKOTEC-BTS for sound insulation and restoration (See page 25)!

#### Further drawing numbers

④ Heating pipe – ⑥ PE foil (recommended if using flowing screeds) – ⑧ Load bearing substrate

**Note:** The architect must always verify whether additional insulation measures, waterproofing or heat or impact sound insulation is required.

# Product service and planning materials

## Performance diagram (example)

The following pages explain the system specific results of thermal technology tests.

The individual diagrams differ by the thermal resistance factors of the corresponding surface covering.

The adjoining output diagram with sample data refers to the Schlüter-BEKOTEC-THERM ceramic thermal comfort floor with use of Schlüter-BEKOTEC-EN/P or-EN/PF.

### Application

The heating output is shown as heat flow density on the lower scale (in this example: at 61 W/m²).

Moving up vertically from the desired heating output, one can determine the corresponding installation spacings of the heating pipes (75, 150, 225 or 300 mm).

When we transfer the intersection of 61 W/m² with an installation spacing of 150 to the left scale, we see the corresponding excess heating temperature of 10 °C.

This temperature indicates how many degrees Celsius the heating water must exceed the desired room temperature on average.

For a room temperature of 20 °C, the heating water on average must therefore be heated to 30 °C to achieve an output of 61 W/m² with an installation spacing of 150 mm between the heating pipes.

If we stay with an excess heating temperature of 10 °C, the table shows the heating output of other spacing options at the intersections.

Tested according to DIN EN 1264

Floor covering: **Ceramic tile, natural stone, cast stone and stoneware**  
incl. Schlüter-DITRA mat.

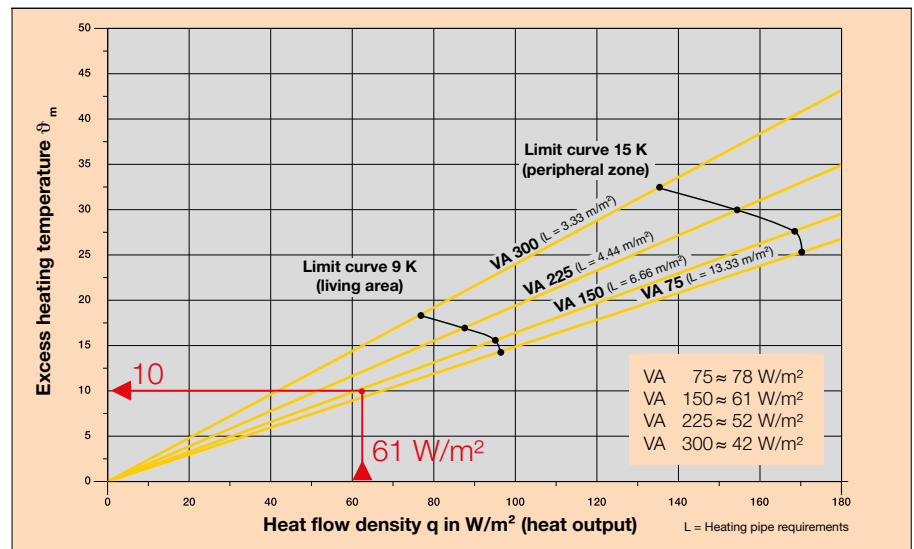

Example:

- $\vartheta_V \triangleq$  Supply temperature = 32.5 °C
- $\Delta\vartheta \triangleq$  Intended temperature splay = 5 °K
- $\vartheta_i \triangleq$  Room temperature = 20 °C

$$\vartheta_m = \frac{\vartheta_V - \vartheta_R}{\ln \frac{\vartheta_V - \vartheta_i}{\vartheta_R - \vartheta_i}}$$

The following can be approximated:

$$\vartheta_m = \left( \vartheta_V - \frac{\Delta\vartheta}{2} \right) - \vartheta_i$$

$$\vartheta_m = \left( 32.5 \text{ K} - \frac{5 \text{ K}}{2} \right) - 20 \text{ K} = 10 \text{ K}$$

Results for heat flow density (heat output for various installation spacings)

### Note

To determine the necessary average heating water temperature, add the excess heating temperature to the desired room temperature.

### Limit curves

#### Limit curve 9K (for living spaces)

This indicates at which point the maximum permissible surface temperature for living spaces is reached. For example, the surface temperature should be limited to 29 °C if a room temperature of 20 °C is desired. If the desired heat output is above the limit curve, a closer installation spacing of the heating pipes should be considered. If there is no way to bring the heating pipes closer together, the floor heating alone is not able to provide the necessary heating output.

The points on the limit curve indicate the maximum heat output of the corresponding installation spacing.

#### Limit curve 15 K (for peripheral zones)

This indicates at which point the maximum permissible surface temperature for peripheral zones is reached. Peripheral zones apply e.g. to the area in front of full length windows and usually extend 1 m into the room. This allows for reaching a maximum surface temperature of 35 °C with a room temperature of 20 °C to counter the cold air coming in through large windows with higher heat output.

The points on the limit curve indicate the maximum heat output of the corresponding installation spacing.

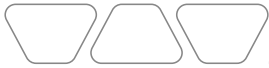

# Product service and planning materials

Certified quality

**Schlüter-BEKOTEC-THERM** is a certified and externally monitored floor heating system.

As part of the certification program for floor heating systems, we are authorised to include the DIN test mark with the registration number 7F165 in our product documentation. Thermal technology testing according to DIN EN 1264, reg. no. HB03 P094 and HB03 P095 was conducted by the independent, accredited DIN CERTCO recognised test laboratory Forschungsgesellschaft HLK, HVAC Laboratory at Stuttgart University.

The heating pipe made of PE RT is based on the corresponding test and monitoring requirements of DIN 16833. It is approved, certified and registered. This registration documents that the **Schlüter-BEKOTEC-THERM-HR** system heating pipe meets the requirements for piping systems for floor heating systems and connections to radiators.



Schlüter-Systems is a member of the German Association for Area Heating Systems (BVF)



Schlüter®-heating system certificate

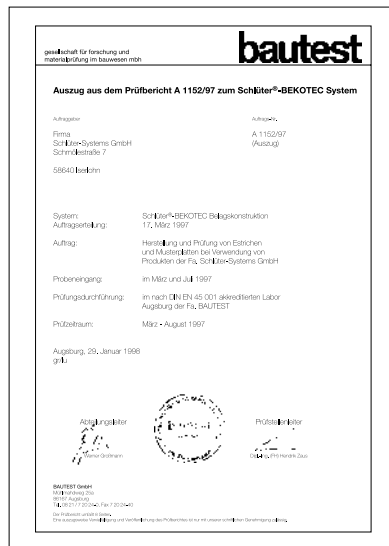

Endurance test and confirmation of the load transfer required according to DIN 1055 by test report A1152/97. The independent accredited laboratory of the Society for Research and Material testing at construction engineering in Augsburg.



The verification of the practical installation of the entire system, including the surface covering, was performed by the **iff technical expert team for construction and floor technology** in Koblenz.



bekotec-therm.com

# Innovative system solutions

## Application and scope

The purpose of this technical brochure and the supplementary materials is to explain the planning and installation of the Schlüter-BEKOTEC-THERM ceramic thermal comfort floor in simple and general terms.

The description refers to the various areas of application (*see pages 16 and 25*). Surface coverings made of ceramic tiles or natural stone and synthetic stone are discussed separately with regard to their suitability for and the installation of floor heating systems. If installing non ceramic surface coverings, the applicable installation guidelines and manufacturer recommendations must be observed for each material. In particular, installers must determine the readiness and residual moisture of the screed in conjunction with the selected surface covering.

The applicable technical construction regulations (GEG, DIN standards, VOB, information sheets, national requirements etc.) must be observed.

All technical statements, recommendations, drawings and images are based on our current theoretical and practical knowledge. They are intended as general information and do not represent design specifications or design services. The information does not release designers and installers from the responsibility to carry out their own plans and specifications. All applicable national regulations, approvals, and standards must be observed.

Schlüter-Systems KG reserves the right to change these documents at any time without citing technical or commercial reasons.

The current documents shall be deemed to represent the current state of the art of Schlüter-Systems KG.

No guarantee for typographic errors.

The reproduction, duplication or usage (including in parts) of this material by third parties is expressly prohibited.



# Attachment I.I

Pressure loss diagram of heating pipes

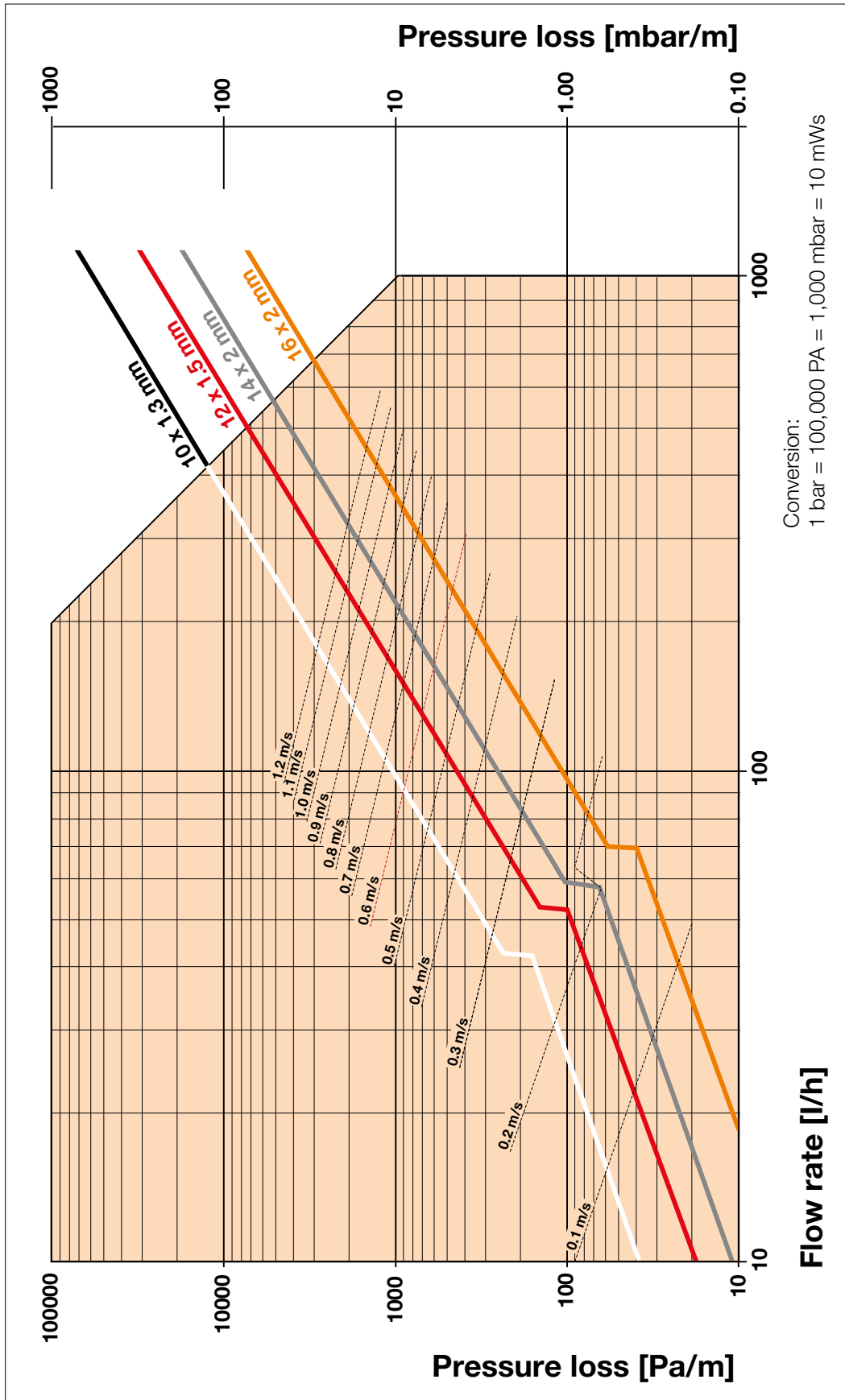

# Attachment I.I

Pressure loss diagrams for heating circuit distributors DN 25

**Pressure loss diagram for flow meters (supply line)**

- HVT/DE (stainless steel distributor)
- HVP (plastic distributor)

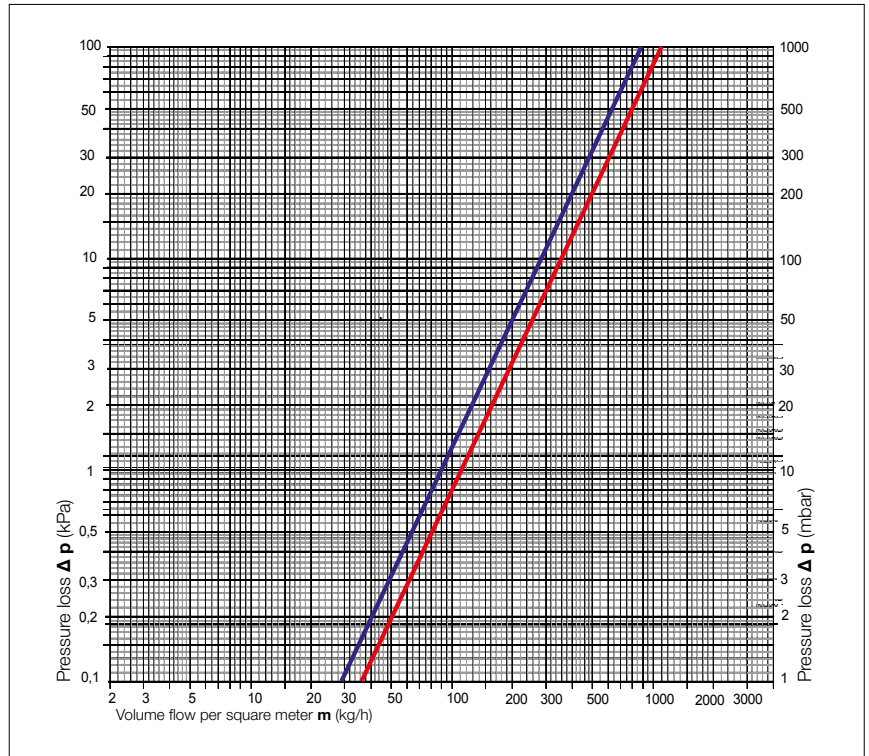

**Pressure loss diagram for thermostat valve (return line)**

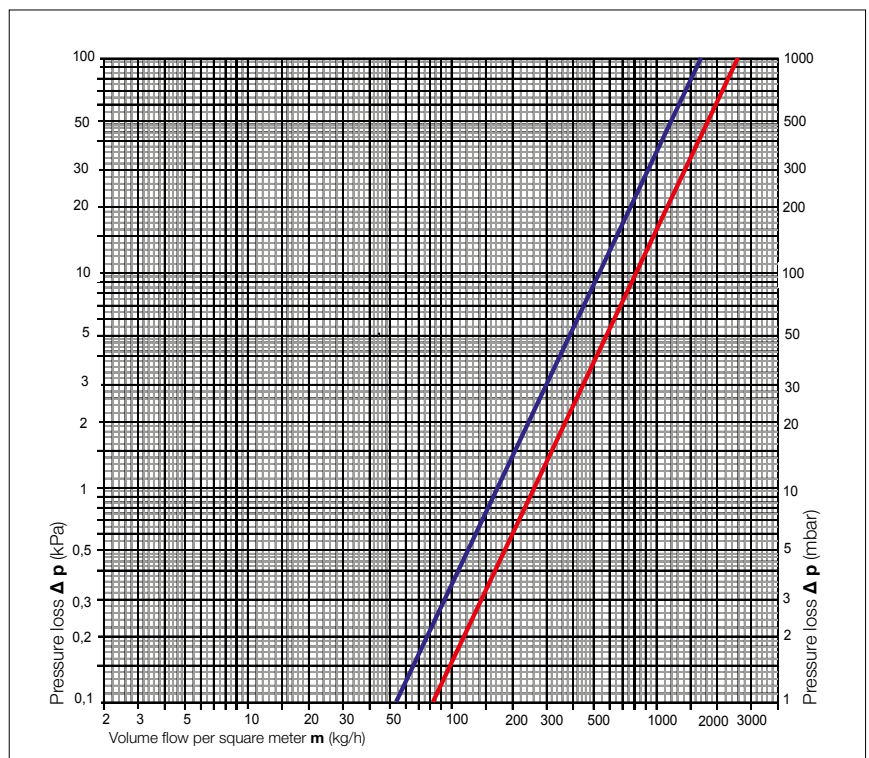

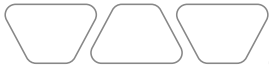

# Attachment I.I

Pressure loss diagrams for high efficiency pump, RTB and RTBR

## Characteristics of the high efficiency pump

Constant differential pressure control  $\Delta p$

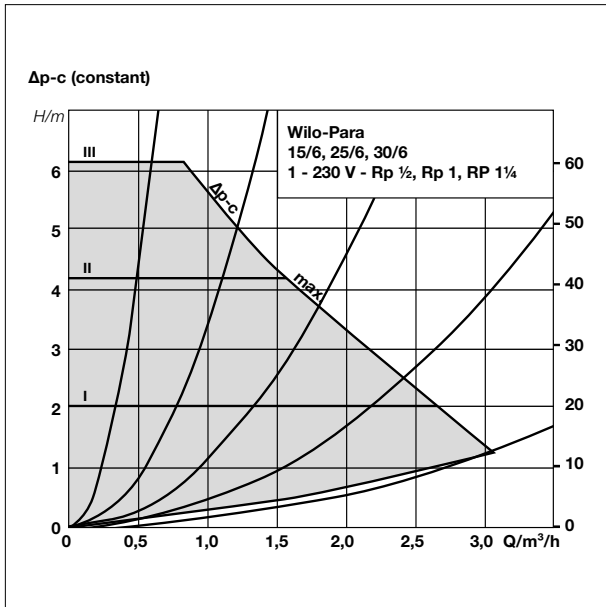

Pressure loss diagram for room temperature limit valve of Schlüter-BEKOTEC-THERM-RTB/-RTBR

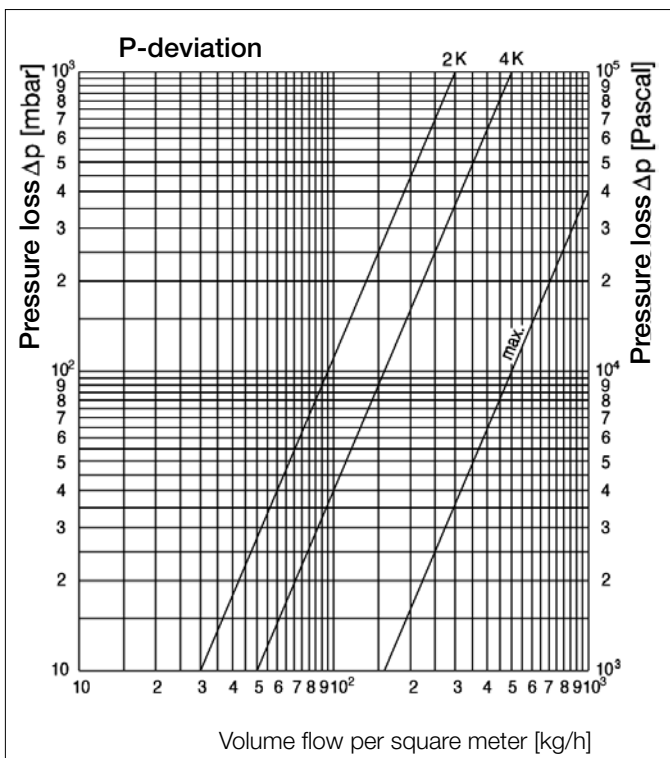

Pressure loss diagram for room temperature valve of Schlüter-BEKOTEC-THERM-RTBR

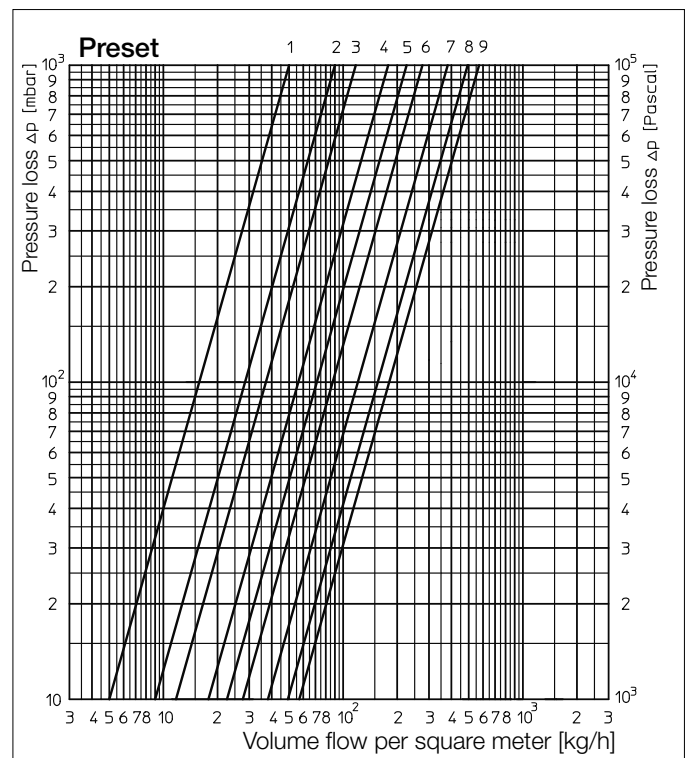

## Attachment I.II

### Impact sound measurements

#### Sound measurements

**Applicable standards:** DIN 4109

**Testing institute:** Acoustics laboratory of CSTC Belgium

#### Structure:

Concrete base

Insulation layer

BEKOTEC

Screed

Thin-bed mortar

DITRA

Thin-bed mortar

Ceramic tiles

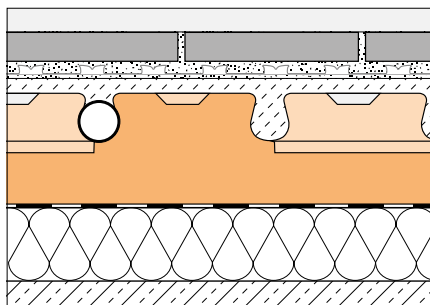

### Requirements for multi storey buildings with apartments and work spaces $\leq 50$ dB

Insulation layer (test material)	Area: 4.17 m x 4.20 m	
	tested values in dB (acc. to test certificate)	* calculated sound values in dB
Raw concrete slab	75	
BEKOTEC without sub insulation		66
BEKOTEC with polystyrene 22/20	48	
BEKOTEC with BTS		56

\* Values were determined and estimated on a comparative area.



# Attachment II.I

## Project specification sheet

**Construction project:** Name: \_\_\_\_\_  
 Address: \_\_\_\_\_  
 Postal code, city: \_\_\_\_\_  
 Phone/Fax: \_\_\_\_\_  
 E mail: \_\_\_\_\_

**Developer:** Name: \_\_\_\_\_  
 Address: \_\_\_\_\_  
 Postal code, city: \_\_\_\_\_  
 Phone/Fax: \_\_\_\_\_  
 E mail: \_\_\_\_\_

**Architect:** Name: \_\_\_\_\_  
 Address: \_\_\_\_\_  
 Postal code, city: \_\_\_\_\_  
 Phone/Fax: \_\_\_\_\_  
 E mail: \_\_\_\_\_

**System installation contractor:** Name: \_\_\_\_\_  
 Address: \_\_\_\_\_  
 Postal code, city: \_\_\_\_\_  
 Phone/Fax: \_\_\_\_\_  
 E mail: \_\_\_\_\_

**Selected system (please check):**

With **Schlüter-BEKOTEC-EN 2520 P**  
 For traditional sand and cement screed

With **Schlüter-BEKOTEC-EN 1520 PF**  
 for flowing screeds

With **Schlüter-BEKOTEC-EN 23 FI 30**  
 Made of high impact structured polystyrene

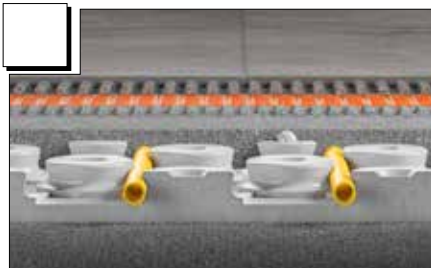

**Selected control technology**

- Room sensor for heating/cooling
- Timer unit
- Room sensor for heating/cooling WL (wireless)
- Timer unit

**Project support**

- Material calculation/offer for BEKOTEC-THERM components
- Floor heating design, table format:
- Heating load calculation (Attachment I.II required)
- Floor heating design drawing (Attachment I.II required)

Engineering cost: \_\_\_\_\_ €  
 Engineering cost: \_\_\_\_\_ €  
 Engineering cost: \_\_\_\_\_ €

**Submitted documents and drawings**

- U value as shown in Attachment I.II, otherwise according to the German Building Energy Act (GEG)
- Drawings, scale 1:50/M 1:100
- Drawing in DXF/ DWG format
- Heating load calculation as per DIN EN 12831
- Specify air circulation, otherwise according to DIN EN 12831, Attachment 1, Table 6
- Air circulation with HVAC equipment, please indicate for each room in the drawing

# Attachment II.I

## Project specification sheet

**Construction project:** Name: \_\_\_\_\_  
 Address: \_\_\_\_\_  
 Postal code, city: \_\_\_\_\_  
 Phone/Fax: \_\_\_\_\_  
 E mail: \_\_\_\_\_

**Developer:** Name: \_\_\_\_\_  
 Address: \_\_\_\_\_  
 Postal code, city: \_\_\_\_\_  
 Phone/Fax: \_\_\_\_\_  
 E mail: \_\_\_\_\_

**Architect:** Name: \_\_\_\_\_  
 Address: \_\_\_\_\_  
 Postal code, city: \_\_\_\_\_  
 Phone/Fax: \_\_\_\_\_  
 E mail: \_\_\_\_\_

**System installation contractor:** Name: \_\_\_\_\_  
 Address: \_\_\_\_\_  
 Postal code, city: \_\_\_\_\_  
 Phone/Fax: \_\_\_\_\_  
 E mail: \_\_\_\_\_

**Selected system (please check):**

With **Schlüter-BEKOTEC-EN 23 F / 23 F PS**  
 Made of high impact structured polystyrene  
 EN 23 F                      EN 23 F PS

With **Schlüter-BEKOTEC-EN 18 FTS**  
 with integrated sound insulation

With **Schlüter-BEKOTEC-EN 12 FK / 12 F PS**  
 Installation directly on load bearing substrate  
 EN 12 F                      EN 12 F PS

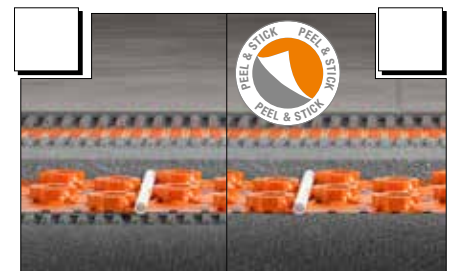

**Selected control technology**

- Room sensor for heating/cooling
- Room sensor for heating/cooling WL (wireless)
- Timer unit
- Timer unit

**Project support**

- Material calculation/offer for BEKOTEC-THERM components
- Floor heating design, table format:
- Heating load calculation (Attachment I.III required)
- Floor heating design drawing (Attachment I.II required)

Engineering cost: \_\_\_\_\_ €  
 Engineering cost: \_\_\_\_\_ €  
 Engineering cost: \_\_\_\_\_ €

**Submitted documents and drawings**

- U value as shown in Attachment I.II, otherwise according to the German Building Energy Act (GEG)
- Drawings, scale 1:50/M 1:100
- Drawing in DXF/ DWG format
- Heating load calculation as per DIN EN 12831
- Specify air circulation, otherwise according to DIN EN 12831, Attachment 1, Table 6
- Air circulation with HVAC equipment, please indicate for each room in the drawing



# Attachment II.I

## Project specification sheet

**Floor coverings:**

Tiles = \_\_\_\_\_ (rooms)  
 Carpet = \_\_\_\_\_ (rooms)  
 Parquet = \_\_\_\_\_ (rooms)  
 Other = \_\_\_\_\_ (rooms)

**Known non covered areas** (air space, bath tub, shower):

Room: \_\_\_\_\_ Size: \_\_\_\_\_ m<sup>2</sup>  
Room: \_\_\_\_\_ Size: \_\_\_\_\_ m<sup>2</sup>  
Room: \_\_\_\_\_ Size: \_\_\_\_\_ m<sup>2</sup>

**Location of distributor** (please enter into the sketch or drawing if possible):

Basement: \_\_\_\_\_ Position  
Ground level: \_\_\_\_\_ Position  
Upper floor: \_\_\_\_\_ Position  
Loft: \_\_\_\_\_ Position

**Internal temperatures according to DIN EN 12831** (enter in drawing):

Living room/dining areas/kitchen/bedrooms 20 °C  
Staircases 15 °C  
Bathrooms 24 °C

**Differing interior temperatures, if desired for your project:**

Room: \_\_\_\_\_ Ti = \_\_\_\_\_ °C  
Room: \_\_\_\_\_ Ti = \_\_\_\_\_ °C  
Room: \_\_\_\_\_ Ti = \_\_\_\_\_ °C  
Room: \_\_\_\_\_ Ti = \_\_\_\_\_ °C

**Information about the heating system**

- Approx. supply temp of heat pump: 30-45 °C
- Thermal solar system with heating support
- Condensed heat generator (boiler)  
(natural gas/oil), approx. supply temp: 30-50 °C
- Utility supplied heat (e.g. municipal utility plant)
- Low temperature heat generator  
(natural gas/oil), approx. supply temp: 75 °C
- \_\_\_\_\_

**Supply temperature**

\_\_\_\_\_ °C  
\_\_\_\_\_ °C  
\_\_\_\_\_ °C  
\_\_\_\_\_ °C  
\_\_\_\_\_ °C  
\_\_\_\_\_ °C

**Offer/drawing required by:** \_\_\_\_\_

Architect/developer: \_\_\_\_\_ Date: \_\_\_\_\_

Signature: \_\_\_\_\_

**Note:** All calculations, specifications and dimensions are intended to support the project design, but cannot serve as project plans in their own right. They must be reviewed and adapted at the sole responsibility of a qualified engineer to verify suitability for a specific purpose.

# Attachment II.II

Building description

- New structure pursuant to EnEV
- Existing structure \_\_\_\_ Year built: \_\_\_\_
- Renovation pursuant to EnEV.

**Conservatories  
(or similar)  
require Attachment II.III!**

	Please enter thicknesses of layers if U value is unknown	U values W/(m <sup>2</sup> K) for your project *1			
		Base-ment	Ground Floor	Top Floor	Loft
➔	<b>1</b> External wall 1.1 _____ cm				
	Layer 1 _____ cm material				
	Layer 2 _____ cm material				
	Layer 3 _____ cm material				
	Layer 4 _____ cm material				
➔	<b>1</b> External wall 1.2 _____ cm				
	Layer 1 _____ cm material				
	Layer 2 _____ cm material				
	Layer 3 _____ cm material				
	Layer 4 _____ cm material				
➔	<b>2</b> External window *2				
➔	<b>3</b> External door				
➔	<b>4</b> Roof				
➔	<b>5</b> Roof light *2				
➔	<b>6</b> Ceiling adjacent to unheated space				
	<b>71</b> Floor adjoining ground (earth)				
	<b>72</b> Floor adjacent to unheated space				
	<b>8</b> Floor adjacent to heated space				
	<b>9</b> Internal wall _____ cm				
	<b>10</b> Internal door				
	<b>11</b> Internal window				

	Ceiling height [m]			
	Base-ment	Ground Floor	Top floor	Loft
H				
H				
H				
H				
H1				
H2				

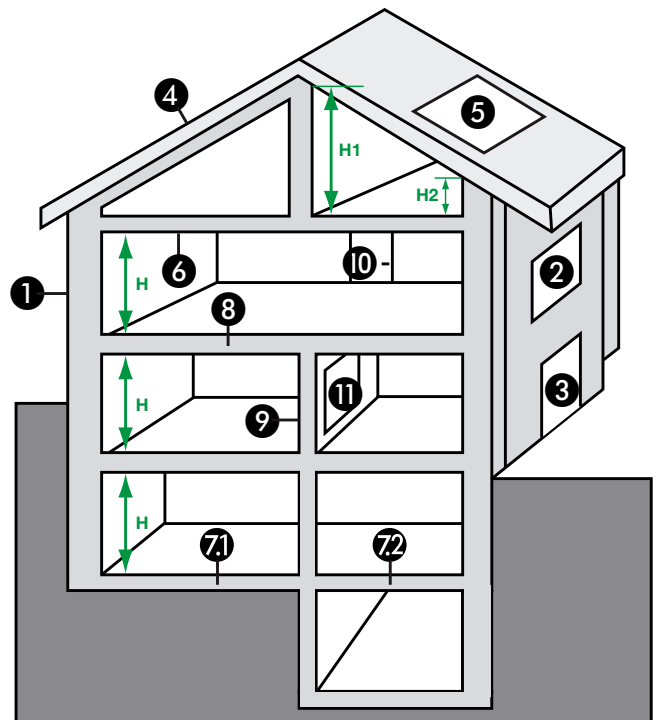

➔ **Mandatory field (if component exists)**

\*1 Project specific U values are required for technical calculations on our heating system

\*2 If U values and window sizes are unknown, please complete Attachment I.III – Window specifications

**Maximum surface temperatures according to DIN-EN 1264**

- Living zone: 29 °C
- Peripheral zone: 35 °C
- Bathrooms: 33 °C

**Your maximum desired floor surface temperatures if different/required**

- Living zone: \_\_\_\_\_ °C
- Peripheral zone: \_\_\_\_\_ °C
- Bathrooms: \_\_\_\_\_ °C



## Attachment II.III

Window or conservatory specifications

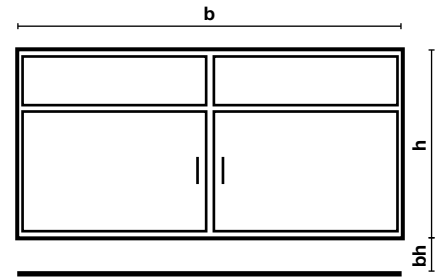

Project no.: \_\_\_\_\_

Construction project: \_\_\_\_\_

							... or	... Enter information here if K value total is unknown			
Floor level	Room	Window position no.*	Window width b [m]	Window height h [m]	Parapet height bh [m]	Total K value** [W/m <sup>2</sup> K]	Manufacturing date***	Single glass/ K value***	Double glass/ K value***	Triple glass/ K value***	

\* Please number the windows with reference to positions in the drawings.

\*\* Total K value refers to windows and frames.

\*\*\* This information is generally found in printed or embossed form on the metal connector between the glass panes. The label often also shows the K value of the window without the frame.

### Further information on winter garden/conservatory

#### Type of utilisation

- Fully used residential space with desired interior temperature of \_\_\_\_\_ °C
- Base temperature \_\_\_\_\_ °C
- Floor heating only (other heating is covered by existing radiators/convection heaters)

#### Transition from winter garden/conservatory to building

- Open design
- Closed design
- Winter garden is not connected to building

#### Roof area of winter garden/conservatory is:

- Fully made of glass with a K value of \_\_\_\_\_ [W/(m<sup>2</sup> K)]
- \_\_\_\_\_ % made of glass (K1) / \_\_\_\_\_ % ceiling cover (K2)... with a K value of K1 \_\_\_\_\_ [W/(m<sup>2</sup> K)] / K2 \_\_\_\_\_ [W/(m<sup>2</sup> K)]
- Insulated with a K value of \_\_\_\_\_ [W/(m<sup>2</sup> K)]
- Non-insulated with a K value of \_\_\_\_\_ [W/(m<sup>2</sup> K)]

#### Additional heaters are:

- Not planned
- Planned – output of radiators/convection heaters: \_\_\_\_\_ W.

## Attachment III

### Filling, flushing and venting the Schlüter®-BEKOTEC-THERM heating circuits

#### I. Prerequisites

1. The leak seal test has been carried out and recorded in accordance with the specifications of DIN EN 1264-4. For the record, see *page 170*.
2. The entire system is disconnected from all power sources and protected from frost.
3. Filling, flushing and venting should be monitored by a qualified technician.  
The subcontractor should specify a fixed procedure for filling and flushing, using the available system specifications.
4. The available connection pressure and the flow velocity are guaranteed based on the use of suitable filling equipment.
5. The connection to the water supply must comply with the applicable regulations.
6. The fill water quality meets the requirements of VDI Guideline 2035 or has been passed through a water processing unit.

#### II. Procedure to fill and vent the Schlüter-BEKOTEC-THERM systems.

##### The system must be filled and flushed in accordance with the following pattern.

Close the ball valves **A** at the heating circuit distributor.

Open the flow meters **B** as described on *page 127*.

Slowly and carefully fill and flush the system, circuit by circuit, working from the lowest heating circuit distributor to the next level.  
The safest method is to flush the heating circuits individually in sequence.

The water flow is routed through the fill/drain tap **C** at the supply line of the distributor bar (HVT/DE or HVP).

The drainage is connected to the return line **D** and routed to an open drainage/outflow **E**, where the water flow is visible.

By opening and closing the manual regulation caps (1 – 4), every heating circuit can now be flushed individually, until no further air bubbles come through the connected drain.

The remaining air in the heating circuit distributor bar is removed through the manual venting valves.

A hydronic adjustment must be performed, as described on *page 127* prior to the first heating.

The requirements described in the section "Installation notes and system start up for various floor coverings" on *page 148* must also be observed.

- A** Ball valves
- B** Flow meter
- C** Filling / draining tap supply line
- D** Filling / draining tap return line
- E** Outflow

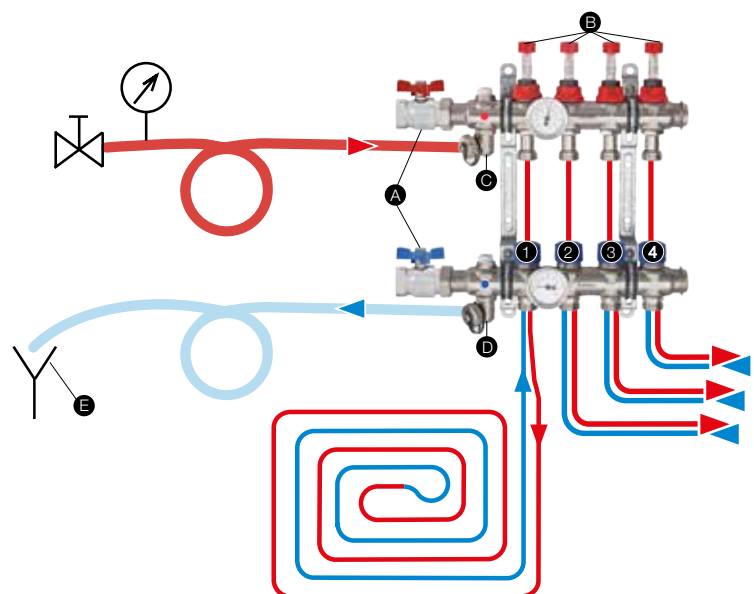



# Attachment IV

## Pressure sample report

**Construction project:** Address: \_\_\_\_\_

Postal code, city: \_\_\_\_\_

**Heating Engineer:** Name: \_\_\_\_\_

Address: \_\_\_\_\_

Postal code, city: \_\_\_\_\_

Phone/Fax: \_\_\_\_\_

**Construction segment:** \_\_\_\_\_

**Level/ apartment:** \_\_\_\_\_

\_\_\_\_\_

**Start of test:** Date \_\_\_\_\_ Time \_\_\_\_\_

**Ambient temperature:** \_\_\_\_\_ °C Water temperature: \_\_\_\_\_ °C

**Max. operating pressure:** \_\_\_\_\_ bar

### Requirements/prerequisites

The leak seal of the system is verified with a water pressure test prior to installing the screed. The test pressure is double the operating pressure, and at least 6 bar. The test pressure must be restored 2 times within 30 minutes, at intervals of 10 minutes. The pressure loss in the subsequent 30 minutes may not exceed 0.6 bar (0.1 bar every 5 minutes). This pressure must be maintained during the installation of the screed.

**Note: The system must be protected from freezing.**

### Test points

Visual inspection of all joints to verify proper installation  yes  no

System components such as expansion vessel

and safety valve with nominal pressures that are not at least equal

to the test pressure are to be excluded from the test  yes  no

System has been filled with cold water, flushed and completely vented  yes  no

Visual inspection of all joints to verify tightness  yes  no

Initial test pressure\*: \_\_\_\_\_ bar Time: \_\_\_\_\_

\* The drop of initial test pressure due to pipe expansion must be offset. Factors to consider include temperature fluctuations.

Final test pressure: \_\_\_\_\_ bar Time: \_\_\_\_\_

During the test period, the system was leakproof  yes  no

No permanent form changes of construction components were apparent.

### Certification of tester

Place/date \_\_\_\_\_ Signature/Company stamp \_\_\_\_\_

## Attachment V

Heating up and cure heating Schlüter®-BEKOTEC-THERM with non ceramic coverings

We hereby certify that we are familiar with the following conditions of the manufacturer, Schlüter-Systems KG, Iserlohn:

Heating / heat curing:

The screed can be heated after 7 days. The supply temperature is increased by  $\leq 5$  °C a day to a maximum of 35°, starting from 25° water temperature. This temperature must then be maintained until the screed is fully cured. The covering is installed once the system has cooled down.

### Certification/explanation

Project: \_\_\_\_\_

Company: \_\_\_\_\_

\_\_\_\_\_

\_\_\_\_\_

### We hereby confirm that the following manufacturer requirements were met.

- a) The screed was not heated within the first 7 days after the installation  
(differing manufacturer specifications must be observed)
- b) The heating process was begun after \_\_\_\_\_ days
  - with a supply temperature of 25 °C
  - The screed was not heated
- c) Heating table

Days of heat curing	Target supply temperature	Read supply temperature	Date, time	Reviewed by
Day 1	25 °C			
Day 2	30 °C			
Day 3	Max. 35 °C			
Day 4	Max. 35 °C			
Day 5	Max. 35 °C			
Day 6	Max. 35 °C			

The heating process was completed on \_\_\_\_\_.

System installation contractor: \_\_\_\_\_ Architect/developer: \_\_\_\_\_

**Note:** This record can also be used for heating a CA or CAF screed to the required temperature for the combination of ceramic/natural stone with Schlüter-DITRA.



# Appendix VI

## CM Measurement Protocol

Client: \_\_\_\_\_

Construction project: \_\_\_\_\_

Screed age: \_\_\_\_\_

- CT** (cement screed)
- CA** (gypsum-based screed)
- CTF** (flowing cement screed)
- CAF** (gypsum-based flowing screed)

Quality class: \_\_\_\_\_

- heated
- unheated
- on insulation

### Moisture content of screeds with relevance for screed readiness\*

Floor covering	CT/CTF heated/unheated	CA/CAF heated	CA/CAF unheated
Ceramic tile/natural stone in conjunction with Schlüter-DITRA	–	≤ 2.0 %	≤ 2.0 %
Textile and vinyl coverings, Parquet and laminate	≤ 1.8 %	≤ 0.5 %	≤ 0.5 %

\* Please observe the corresponding product data sheets and installation guidelines of the floor covering manufacturer regarding residual moisture in the screed.

**Note:** Certificate forms for heat curing can be found in *Attachment V*.

Measurement	Place	Weight (g)	Measured pressure (bar)	Water content (%)
1				
2				
3				
4				
5				

Screed area to be covered: \_\_\_\_\_ m<sup>2</sup>

Comments/witness: \_\_\_\_\_

\_\_\_\_\_

\_\_\_\_\_

Date/Signature

\_\_\_\_\_

Date/Signature of customer

## Schlüter®-DITRA-HEAT-E in combination with Schlüter®-BEKOTEC-THERM

The uncoupling and warming system Schlüter-DITRA-HEAT-E is an optimal supplement for Schlüter-BEKOTEC-THERM when it comes to year-round floor temperature control.

Using the central heating system exclusively for the bathroom is not an economical choice, especially in seasonal transition periods in the spring or autumn. During these times of the year, warming the floor with DITRA-HEAT-E can be a helpful supplement for BEKOTEC-THERM.

Since the heating cable is installed directly underneath the ceramic tile covering, the system is highly responsive. When installed in floor-level showers, DITRA-HEAT-E also assists with the quick drying of the shower area to actively prevent mould growth.

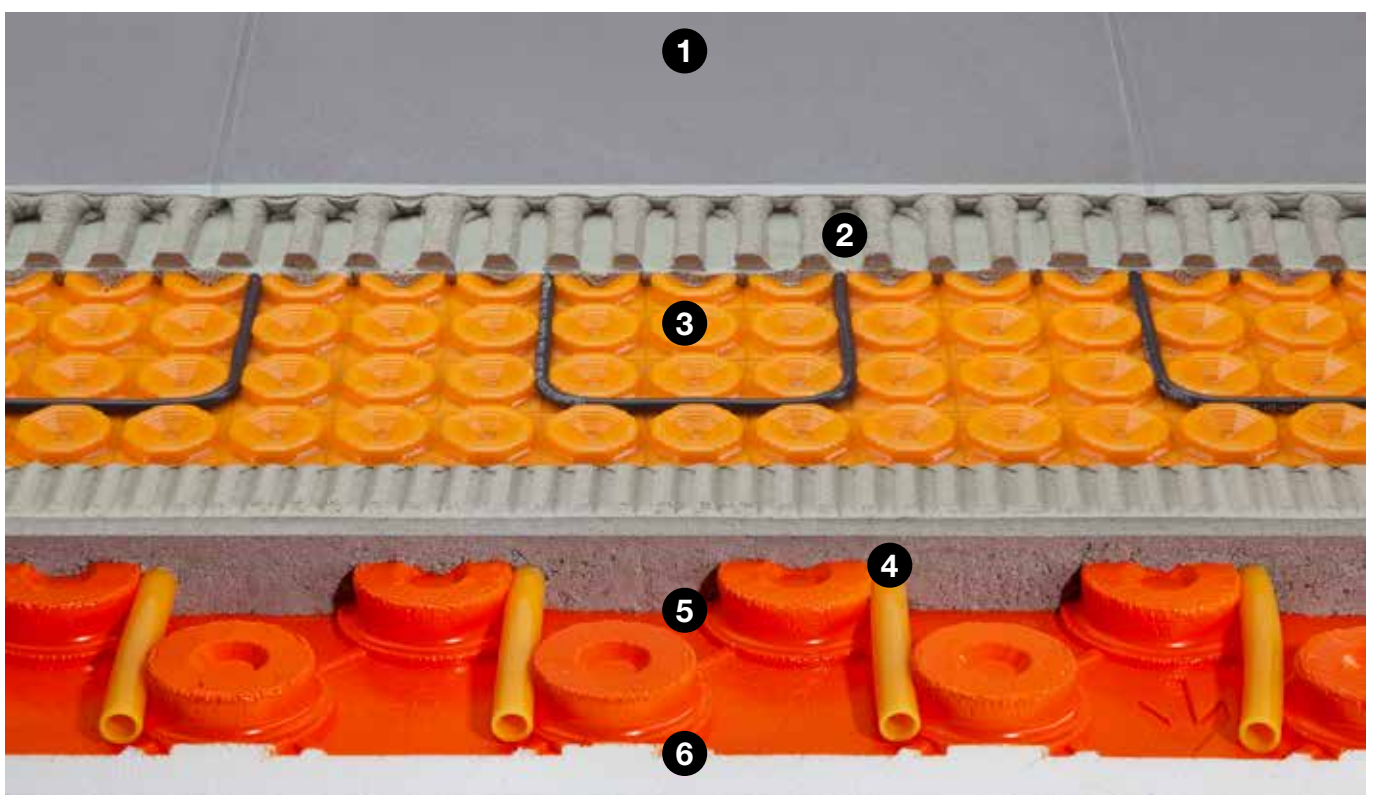

- |  |   |  |
|--|---|--|
| <b>1</b> Ceramic covering                        | <b>3</b> Schlüter®-DITRA-HEAT                 | <b>5</b> Schlüter®-BEKOTEC-EN              |
| <b>2</b> Schlüter®-DITRA-HEAT-E-HK heating cable | <b>4</b> Schlüter®-BEKOTEC-EN HR heating pipe | <b>6</b> sub-floor insulation (DEO or DES) |

**i**

### Note:

We don't recommend using Schlüter-DITRA-HEAT-DUO/-DUO-PS over Schlüter-BEKOTEC-THERM since the 2 mm fleece layer would interfere with the heat dissipation of the warm water floor heating system.



# Schlüter®-BEKOTEC controller with Schlüter®-DITRA-HEAT-E controller

Small tasks don't always need their own solutions.

The Schlüter-DITRA-HEAT-E-Controllers with room control function (exception: analogue DITRA-HEAT-E-Controller RT4) can also be used to operate our actuators Schlüter-BEKOTEC-THERM BTESA 230 V2. That can be an advantage in projects involving individual rooms, exhibit spaces or car dealerships.

Please contact our Technical Department for further information.

## Example: 2 rooms with 3 heating circuits and 3 actuators each

Standard control components	Control component with DH controllers
6 x actuator ESA 230 V2	6 x actuator ESA 230 V2
2 x room sensor ER	—
1 x base module EBC	—
1 x timer EET	—
1 x connection module EAR	—
—	2 x DH controller

## Connection diagram:

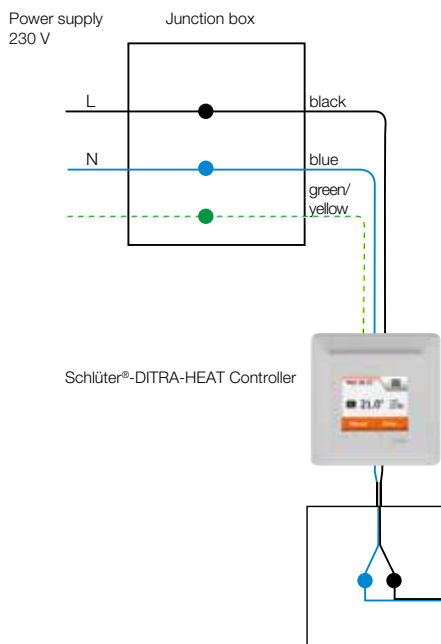

## Application examples

ESA 230 V2 on a zone valve for large-scale properties

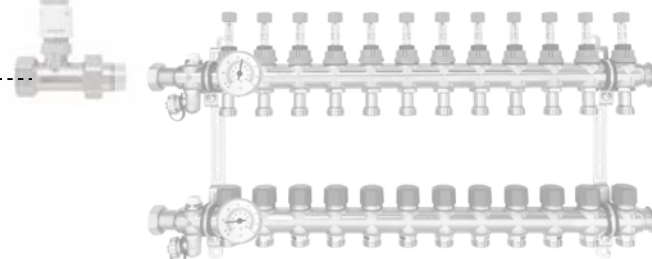

ESA 230 V2 actuator for individual control

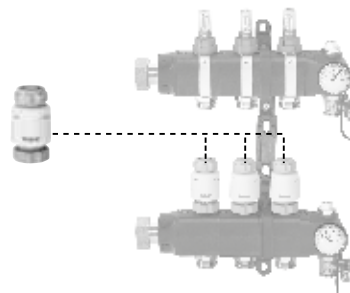

ESA 230 V2 actuator for individual room control

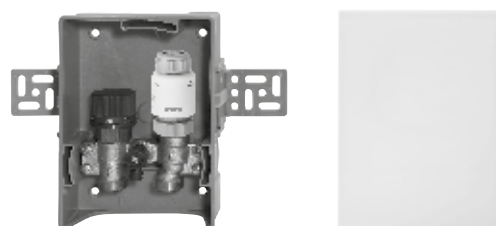

**Note:**  
**Schlüter®-DITRA-HEAT-E-Controller**  
Select "Room" in the "Sensor application" menu item.  
When this application is selected, no floor sensors have to be installed.

## Schlüter®-DITRA-HEAT-E

Electrical wall heating – Covers additional heat requirement in the bathroom

Due to their size, bathrooms are often difficult to heat with a floor heating system. In such cases, the electrical wall heating system Schlüter-DITRA-HEAT-E is an ideal supplement for a ceramic thermal comfort floor to cover the existing heat demand. The zones to be heated can be individually adapted to the requirements of developers and users, for example by integrating a heated wall in a shower area.

- ✓ Durable and maintenance-free.
- ✓ Easy to retrofit.
- ✓ Fast heat-up response.
- ✓ Simple to install.
- ✓ Low assembly height.
- ✓ Convenient complete sets.

For more information, visit our website at:  
[schlueter.com](http://schlueter.com)



[qr.schlueter.com](http://qr.schlueter.com)



© Atlas Concorde





## List of standards and regulations referenced in this Schlüter®-BEKOTEC-THERM Manual

<b>DIN EN 1264-1</b>	Water based surface embedded heating and cooling systems Part 1: Definitions and symbols
<b>DIN EN 1264-2</b>	Water based surface embedded heating and cooling systems Part 2: Floor heating: Prove methods for the determination of the thermal output using calculation and test methods
<b>DIN EN 1264-3</b>	Water based surface embedded heating and cooling systems Part 3: Dimensioning
<b>DIN EN 1264-4</b>	Water based surface embedded heating and cooling systems Part 4: Installation
<b>DIN EN 1264-5</b>	Water based surface embedded heating and cooling systems Part 5: Heating and cooling surfaces embedded in floors, ceilings and walls - Determination of the thermal output
<b>DIN EN 1991-1-1</b>	Eurocode 1: Actions on structures - Part 1-1: General actions - Densities, self-weight, imposed loads for buildings
<b>Coordination of interfaces</b>	BVF coordination of interfaces for radiant heating and cooling systems in existing buildings
<b>DIN 18560-1</b>	Floor screeds in building construction Part 1: General requirements, testing and construction
<b>DIN 18560-2</b>	Floor screeds in building construction Part 2: Floor screeds and heating floor screeds on insulation layers (floating screeds)
<b>DIN 18202</b>	Tolerances in building construction - Buildings
<b>DIN 4109</b>	Sound insulation in buildings
<b>DIN 4108 - 6</b>	Thermal insulation and energy economy in buildings Part 6: Calculation of annual heat and energy use
<b>DIN 4108 - 10</b>	Thermal insulation and energy economy in buildings Part 10: Application-related requirements for thermal insulation materials - Factory made products
<b>DIN EN 13813</b>	Screed material and floor screeds - Screed materials - Properties and requirements
<b>DIN 18534-2</b>	Waterproofing for indoor applications Part 2: Waterproofing with waterproofing materials in sheet form
<b>DIN EN ISO 10140</b>	Acoustics - Laboratory measurement of sound insulation of building elements Part 3: Measurement of impact sound insulation
<b>DIN 16833</b>	Polyethylene pipes of raised temperature resistance (PE-RT) - PE-RT Type I and PE-RT Type II - General quality requirements, testing
<b>DIN 16834</b>	Polyethylene pipes of raised temperature resistance (PE-RT) - PE-RT Type I and PE-RT Type II - Dimensions
<b>DIN 4724</b>	Plastic piping systems for warm water floor heating systems and radiator pipe connecting - Crosslinked polyethylene of medium density (PE-MDX)
<b>DIN 4726</b>	Warm water surface heating systems and radiator connecting systems - Plastic piping systems and multilayer piping systems
<b>DIN 18365</b>	German construction contract procedures (VOB) - Part C: General technical specifications in construction contracts (ATV) - Flooring works
<b>DIN 1055</b>	Actions on structures
<b>DIN EN 12831</b>	Energy performance of buildings - Method for calculation of the design heat load

The laws and standards referenced in this BEKOTEC-THERM Manual are applicable in their version in effect at the time of printing.

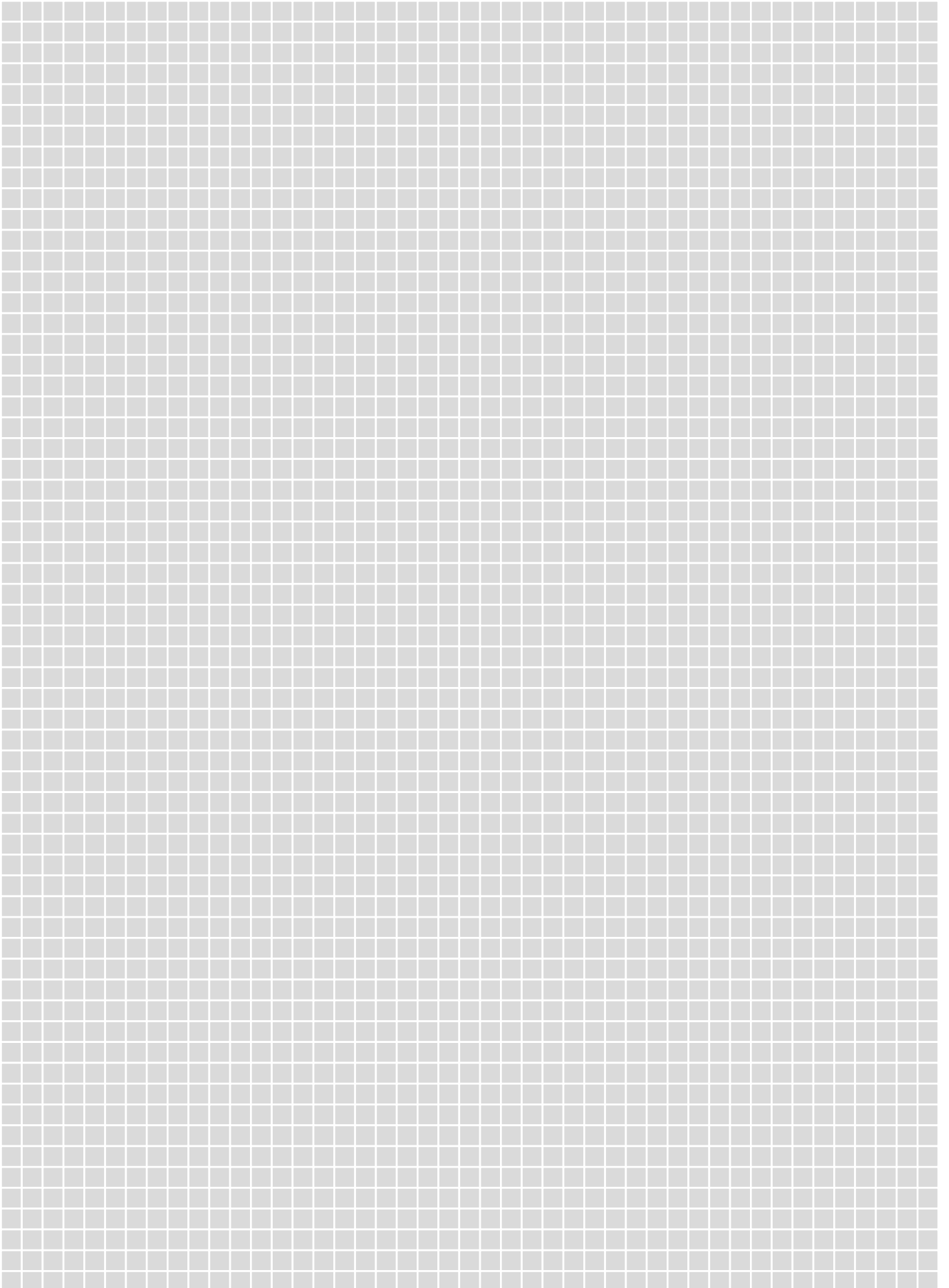

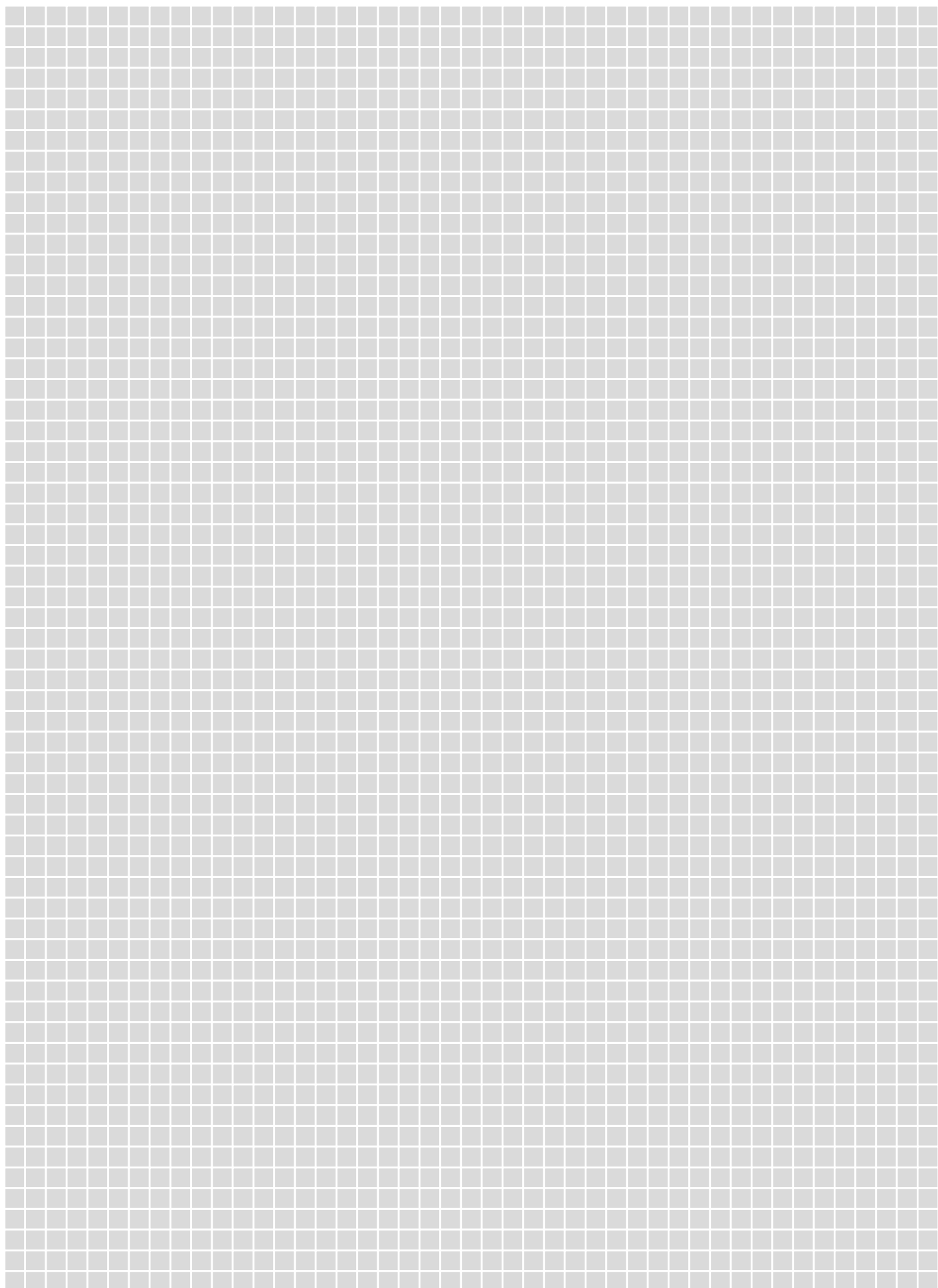

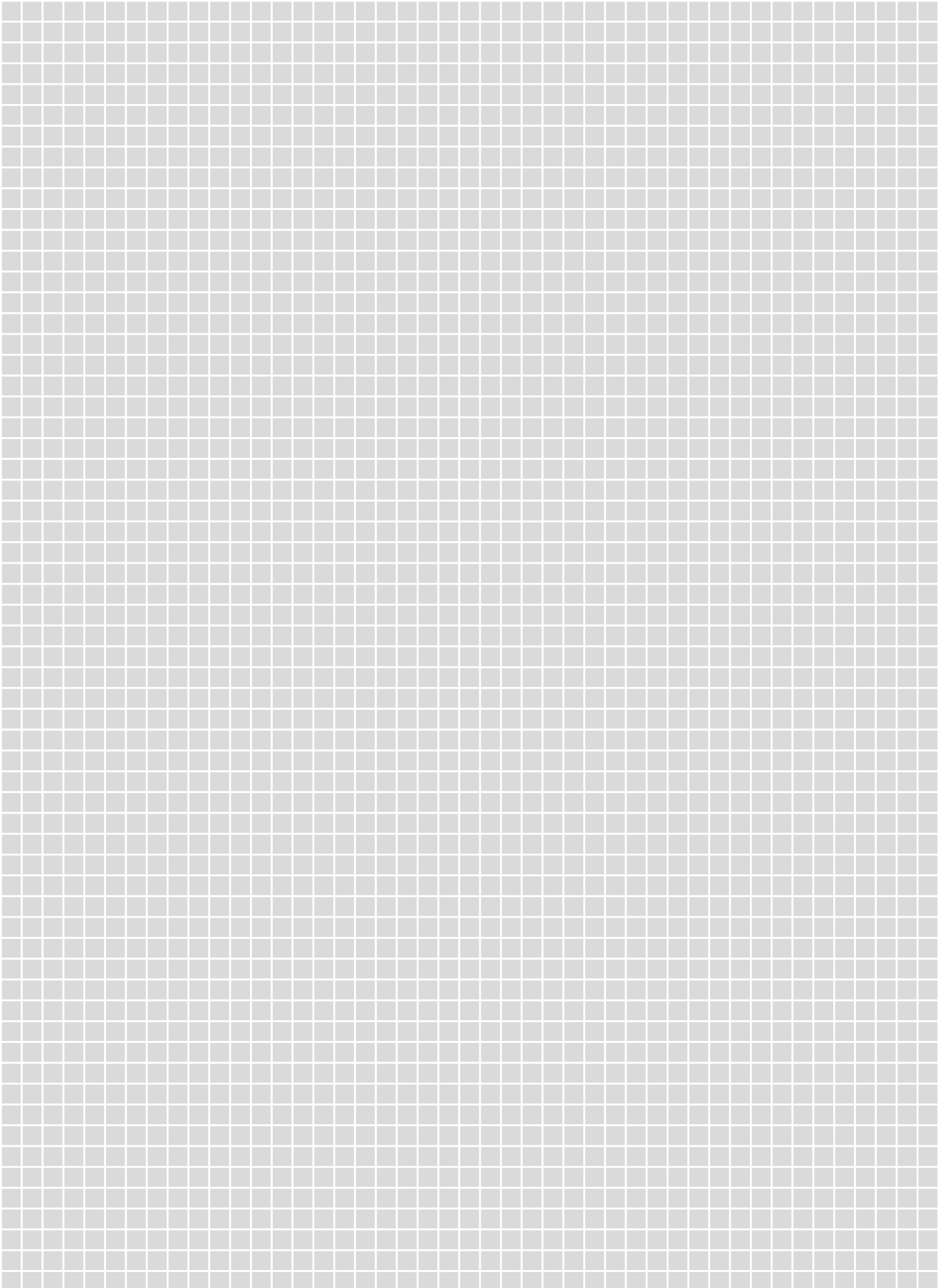

# Learn more online

Would you like to know more about Schlüter-Systems?  
The quickest way is to visit our website.

[schlueter-systems.com](http://schlueter-systems.com)



You can also follow us on Instagram, Facebook and YouTube.



Healthy  
Living with  
Ceramics

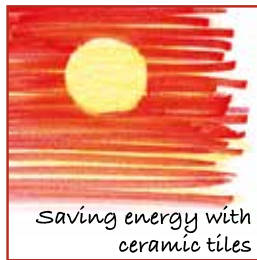

saving energy with  
ceramic tiles

... made by Schlüter-Systems  
[www.bekotec-therm.co.uk](http://www.bekotec-therm.co.uk)



Bundesverband Flächenheizungen  
und Flächenkühlungen e.V.



[bekotec-therm.com](http://bekotec-therm.com)



[www.bvf-siegel.de](http://www.bvf-siegel.de)

**Schlüter-Systems KG** Schmölestraße 7 | D-58640 Iserlohn

+49 2371 971-0 +49 2371 971-1112 [export@schlueter.de](mailto:export@schlueter.de) [schlueter-systems.com](http://schlueter-systems.com)