

Schlüter®-DILEX-STF

Structural movement profile

made of aluminium - for areas with extensive traffic

4.24

Product data sheet



Application and function

Schlüter-DILEX-STF is a maintenance free structural movement profile made of aluminium. The anchoring legs of the profile assembly are connected to the structure with appropriate screw fixings. The covering assembly is then installed abutting the profile.

The sliding telescopic centre section is able to absorb horizontal movements of ± 6 mm (with a joint width of 40 mm) or ± 10 mm (with a joint width of 50 mm). The joint connections absorb three-dimensional movement, enabling the profile to accommodate movement in the structure.

DILEX-STF is designed for use in areas with extensive foot and forklift traffic, e.g. in warehouses and production facilities, shopping centres, airports, railway stations, multi-storey car parks or floor surfaces maintained with cleaning machines.

Material

The profile is available in the following material version:

A = aluminium

Material properties and areas of application:

Schlüter-DILEX-STF are profiles made of untreated aluminium. For production-related reasons, minor flaws such as tool traces are unavoidable on untreated metal surfaces made of aluminium. Such marks are characteristic of the production process and don't impact product functionality.

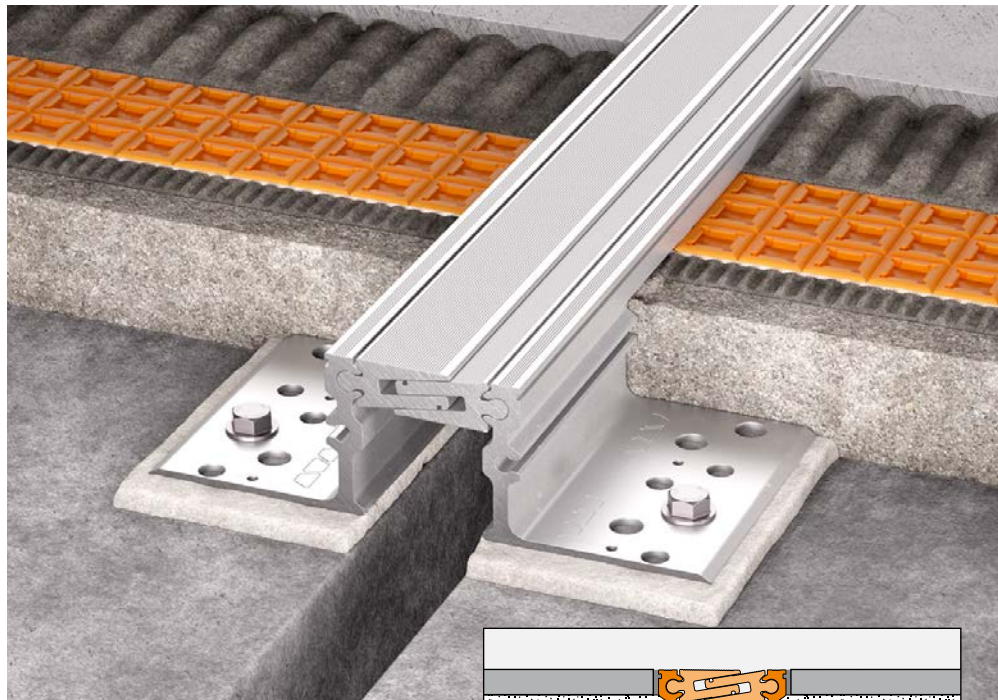

The suitability of DILEX-STF should be reviewed based on the anticipated chemical stresses. Aluminium is sensitive to alkaline media. Cementitious materials, in conjunction with moisture, become alkaline, which may result in corrosion depending on the concentration and length of exposure (aluminium hydroxide formation). For this reason, remove mortar or grouting material immediately from all visible areas and do not cover freshly installed coverings with plastic sheeting. Solidly embed the profile in the assembly to prevent alkaline water from accumulating in small cavities.

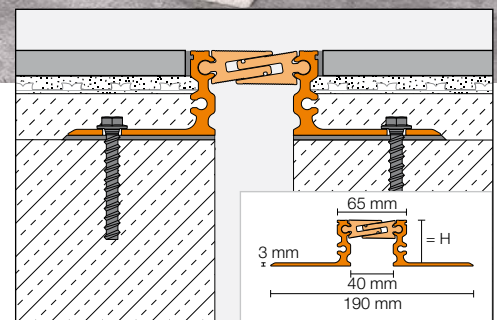

Schlüter-DILEX-ASTF 40

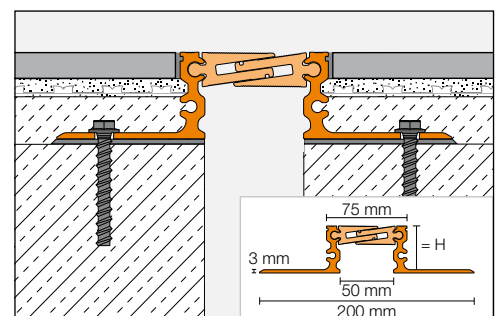

Schlüter-DILEX-ASTF 50



Installation

1. All design specifications of the product must be observed. Select the profile according to the width of the structural movement joint and the height of the covering assembly. The anchoring legs of DILEX-STF may not protrude into the joint (Figure 1), i.e. the width of the profile should not be less than the width of the movement joint in the structure.
2. Apply a levelling/anchoring layer of non-shrink cementitious mortar/grout if the substrate is not level or if a height adjustment is needed. Do not allow the mortar/grout to encroach into the structural joint. If necessary, use an on-site joint filler material.
3. Solidly embed DILEX-STF and align the top edge of the profile flush with the subsequent top edge of the joint filler. The profile should not be higher than the covering surface, but rather up to approx. 1 mm lower (Figure 2).
4. The bilateral bond results exclusively from the mechanical connection with the respective structural element (Figure 3). We recommend the use of concrete anchor bolts Fischer UltraCut FBS II 8 x 70 20/5 US TX or equivalent products. Select at least 7 attachment points per metre or one attachment point every 30 cm for each anchoring leg (Figure 4).
Note: Do not remove the pre-mounted spacers before or during the profile installation; these may only be taken off when the profile is completely installed (Figure 5)!
5. The covering assemblies are then installed abutting the profile. Make sure that the top edge of the profile is flush with the top edge of the joint filler and to leave a sufficient space for elastic filler. Full coverage must be obtained between the tile and the profile's anchoring leg. Always adjoin the uncut tile edge to the profile.
6. Completely fill the space between the top covering and the profile with a neutral crosslinking elastic filler - then peel off the pre-adhered release film immediately (Figure 6).

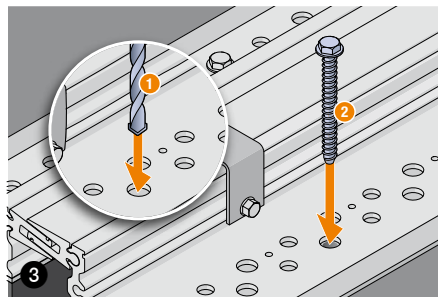
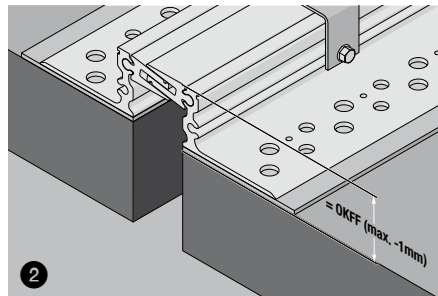
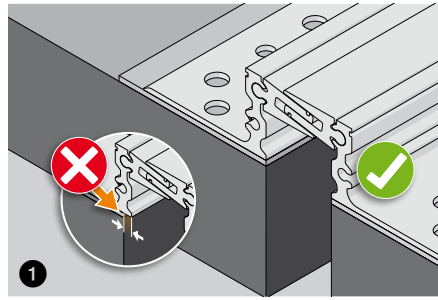

Notes

Schlüter-DILEX-STF requires no special maintenance or care. The oxidation layer on aluminium can be removed by using a conventional polishing agent, but will form again.

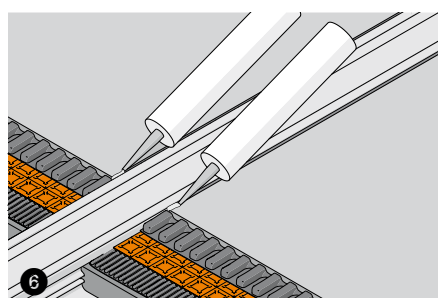
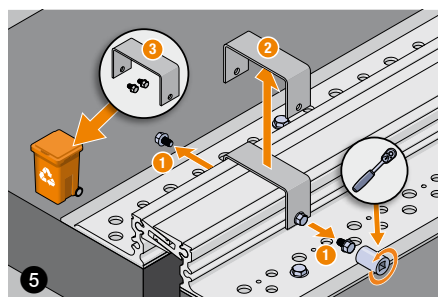
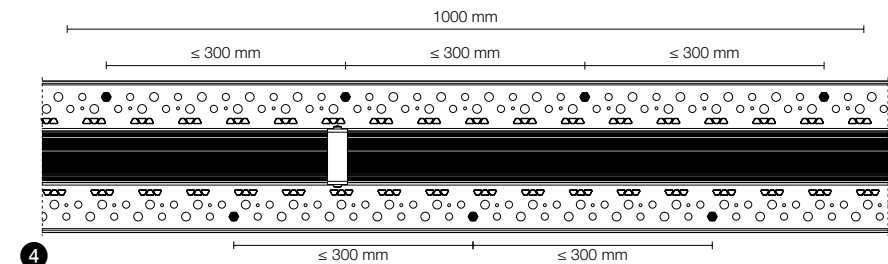
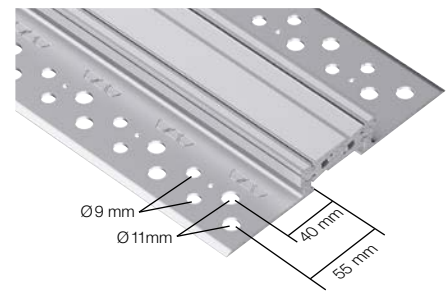



Product overview:

Schlüter®-DILEX-ASTF 40

A = aluminium

Supplied length: 3.00 m

Height	A
H = 22 mm	•
H = 40 mm	•
H = 52 mm	•

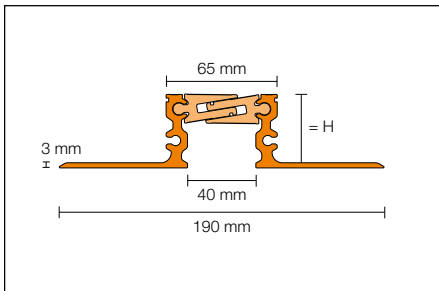

Schlüter®-DILEX-ASTF 50

A = aluminium

Supplied length: 3.00 m

Height	A
H = 22 mm	•
H = 40 mm	•
H = 52 mm	•

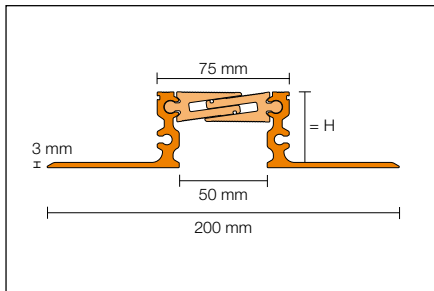

Movement absorption







DILEX-ASTF 40	6.0 mm	6.0 mm	± 7.0 mm
DILEX-ASTF 50	10.0 mm	10.0 mm	± 12.0 mm

Recommended cutting tools

Material	Recommended cutting tools
Aluminium	  Saw blade for nonferrous metals

Follow all safety instructions and specifications provided by the cutting tool manufacturer, including the use of safety goggles, ear protection and gloves. Irrespective of the cutting tool used, ensure that all burr is removed from the profile ends with a file or similar.

Application area based on local traffic volume

-  **Persons**
-  **Shopping carts**
Total weight max. 0,6 t
-  **Cars**
Total weight max. 3,5 t
-  **Trucks**
Total weight max. 300 kN
-  **Forklifts**
Pneumatic tyres / Solid rubber tyres
Total weight max. 69 kN
-  **Pallet trucks**
Hard rubber tyres
Total weight max. 6,5 kg/mm (pallet trucks with tandem axles only)



● permissible



Schlüter-Systems KG  Schmölestraße 7 | D-58640 Iserlohn

 +49 2371 971-0  +49 2371 971-1111  info@schlueter.de  schlueter-systems.com

Schlüter-Systems Ltd  Units 3-6 Bardon 22 Industrial Estate | Bardon Hill | Coalville | Leicestershire | LE67 1TE

 +44 (0) 1530 813396  sales@schluter.co.uk  schluter.co.uk