

Schlüter®-ECK-K / -KHK

Wall corners & transitions
stainless steel edge protection

2.7

Product data sheet

Application and Function

Schlüter-ECK-K is a stainless steel corner profile that is subsequently installed to protect the external corners of tiled walls or other wall coverings. It offers excellent protection of edges that are subject to mechanical stresses, e.g. in industrial kitchens, meat processing plants, public bathrooms and hospitals etc. The profile covers damaged edges to avoid the need for replacement and remodelling. Schlüter-ECK-K as an external wall corner can be combined with the cove shaped stainless steel profiles Schlüter-DILEX-EHK as an internal corner and Schlüter-DILEX-HKS as a floor/wall transition.

Schlüter-ECK-KHK is a cove shaped, stainless steel corner profile that is subsequently adhered at the internal corners of tiled walls or other wall coverings. The profile covers damaged spots or imperfect internal corners to avoid the need for replacement and remodelling. Pre-formed external and internal corners as well as connectors are available for the profile type Schlüter-ECK-KHK.

Schlüter-ECK-K /-KHK is particularly suitable for hygienically sensitive areas, where an appealing visual design is as important as ease of cleaning, e.g. in hospitals, industrial kitchens, clean rooms, washrooms, and in food preparation areas etc.

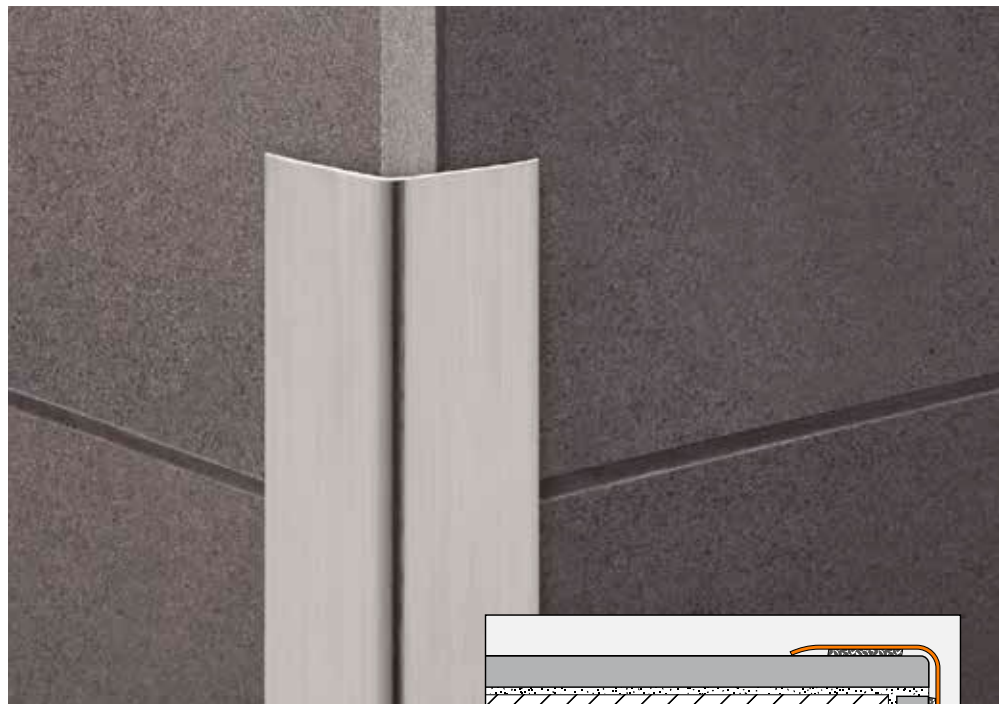

Material

Schlüter-ECK-K /-KHK is available in the following material varieties:

E = stainless steel

V2A material no. 1.4301 = AISI 304

V4A material no. 1.4404 = AISI 316L

(ECK-K only)

The visible surfaces of the profile are covered with a protective foil.

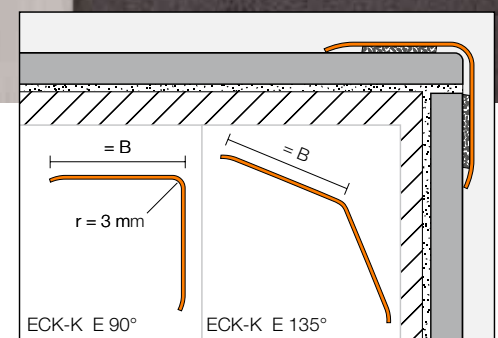

External corners



Material properties and areas of application:

In special cases, the suitability of a proposed type of profile must be verified based on the anticipated chemical, mechanical, and/or other stresses.

Schlüter-ECK-K /-KHK are made of roll-formed stainless steel V2A (material no. 1.4301) or V4A (material no. 1.4404). They are particularly well suited for applications that, in addition to heavy mechanical stresses, require resistance to chemicals such as acidic or alkaline media and detergents. Depending on the anticipated stresses, Schlüter-ECK-E is available in the alloy materials 1.4301 or 1.4404. The use of 1.4404 is recommended if consistent chemical exposure is expected, for example in the case of swimming pools (fresh water). Even stainless steel of quality 1.4404 is not resistant to all chemical stresses, and may be affected, e.g., by hydrochloric and hydrofluoric acid or certain chloride and brine concentrations. In certain cases, this also applies to seawater pools. Special anticipated stresses should therefore be verified in advance.

Installation

- Schlüter-ECK-K /-KHK profiles are adhered to fully tiled wall corners with the installation adhesive Schlüter-KERDI-FIX or an equivalent material. Apply one line of adhesive to the back of the profile's anchoring legs and then press it onto the edge or corner or the covering in such a way that the lateral edges are fully attached. Prior to applying the installation adhesive, remove all substances that may weaken the bond (e.g. grease, etc.) from the attachment areas.
- Use a suitable detergent to remove all excess adhesive squeezed out from below the profile's anchoring legs.
- Remove the protective foil.

Maintenance

Schlüter-ECK-K /-KHK requires no special maintenance or care. Use suitable detergents to remove contamination as part of the regular cleaning of the coverings. The visible areas of the profiles can be polished with commercial chrome polishing products. Stainless steel surfaces exposed to the environment or aggressive substances should be cleaned periodically using a mild household cleaner.

Regular cleaning maintains the neat appearance of stainless steel and reduces the risk of corrosion. All cleaning agents must be free of hydrochloric acid.

Avoid contact with other metals such as steel, since this can cause extraneous rust. This also includes tools such as trowels or steel wool, i.e. tools used to remove mortar residue.

We recommend the use of the stainless steel cleaning polish Schlüter-CLEAN-CP.

Product Overview

Schlüter®-ECK-K

E = stainless steel, EB = brushed stainless steel,
E V4A = stainless steel 1.4404 (V4A)
Length supplied: 1.50 m, 2.00 m, 2.50 m, 3.00 m

Material	E	EB	E V4A
B = 15 mm	•	•	
B = 32 mm	•	•	•
B = 50 mm	•	•	
B = 32 mm / 135°	•		



Schlüter-ECK-K 15 EB

Schlüter®-ECK-KHK

E = stainless steel, EB = brushed stainless steel
Length supplied: 1.50 m, 2.00 m, 2.50 m, 3.00 m

Material	E	EB
	•	•



Schlüter-ECK-KHK

Schlüter®-ECK-KHK

Corners and connectors

Material	E	EB
External corners	•	•
Internal corners (2 legs)	•	•
Internal corners (3 legs)	•	•
Connector	•	•

Schlüter-Systems KG | Schmölestraße 7 | D-58640 Iserlohn

+49 2371 971-0 | +49 2371 971-1111 | info@schlueter.de | schlueter-systems.com

Schlüter-Systems Ltd | Units 3-6 Bardon 22 Industrial Estate | Bardon Hill | Coalville | Leicestershire | LE67 1TE

+44 (0) 1530 813396 | sales@schlueter.co.uk | schlueter.co.uk